

# The Sega Light Phaser™

---

## Instructions

IMPORTANT: Light Phaser Series software  
required for proper operation.

**SEGA®**



# To use the Sega Light Phaser™ just follow these simple steps:

**1.** After you have properly connected the Sega Power Base™, plug the light phaser into Control 1 on the power base.

**2.** With the power OFF, insert the Sega card\* or cartridge\* into the proper slot.

\*Caution: Light Phaser will *not* operate properly without this special software.

**3.** Turn the power ON. Position the light phaser in front of the TV, approximately four to six feet away.

**4.** To start the game, pull the trigger.

**5.** When aiming at an on-screen target, line up the light phaser's front sight so that it is seen between the rear sight. (See illustration right)

**6.** The light phaser will *not* control the movements of an on-screen object. It is meant to be used in shooting-type games only.

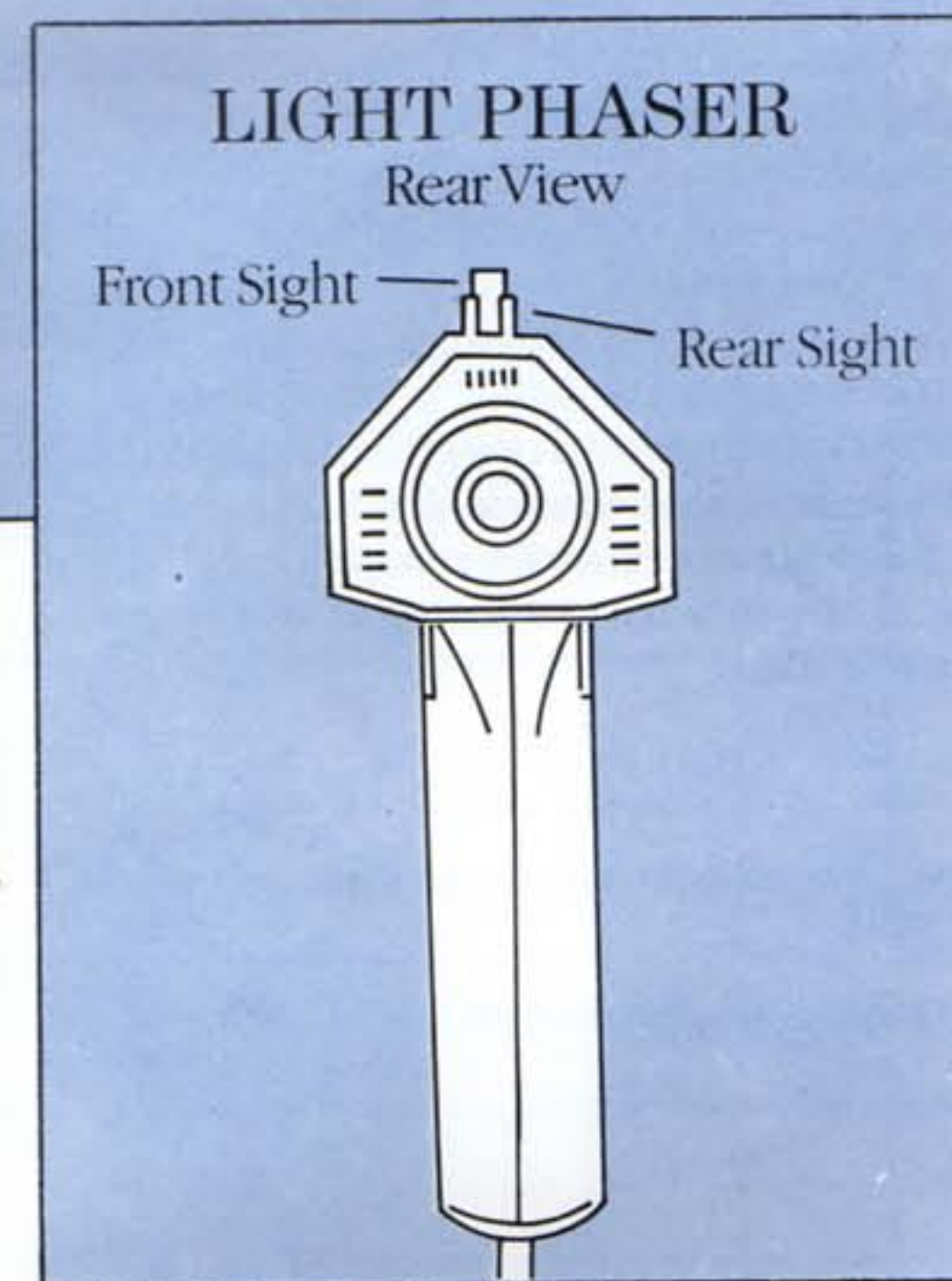
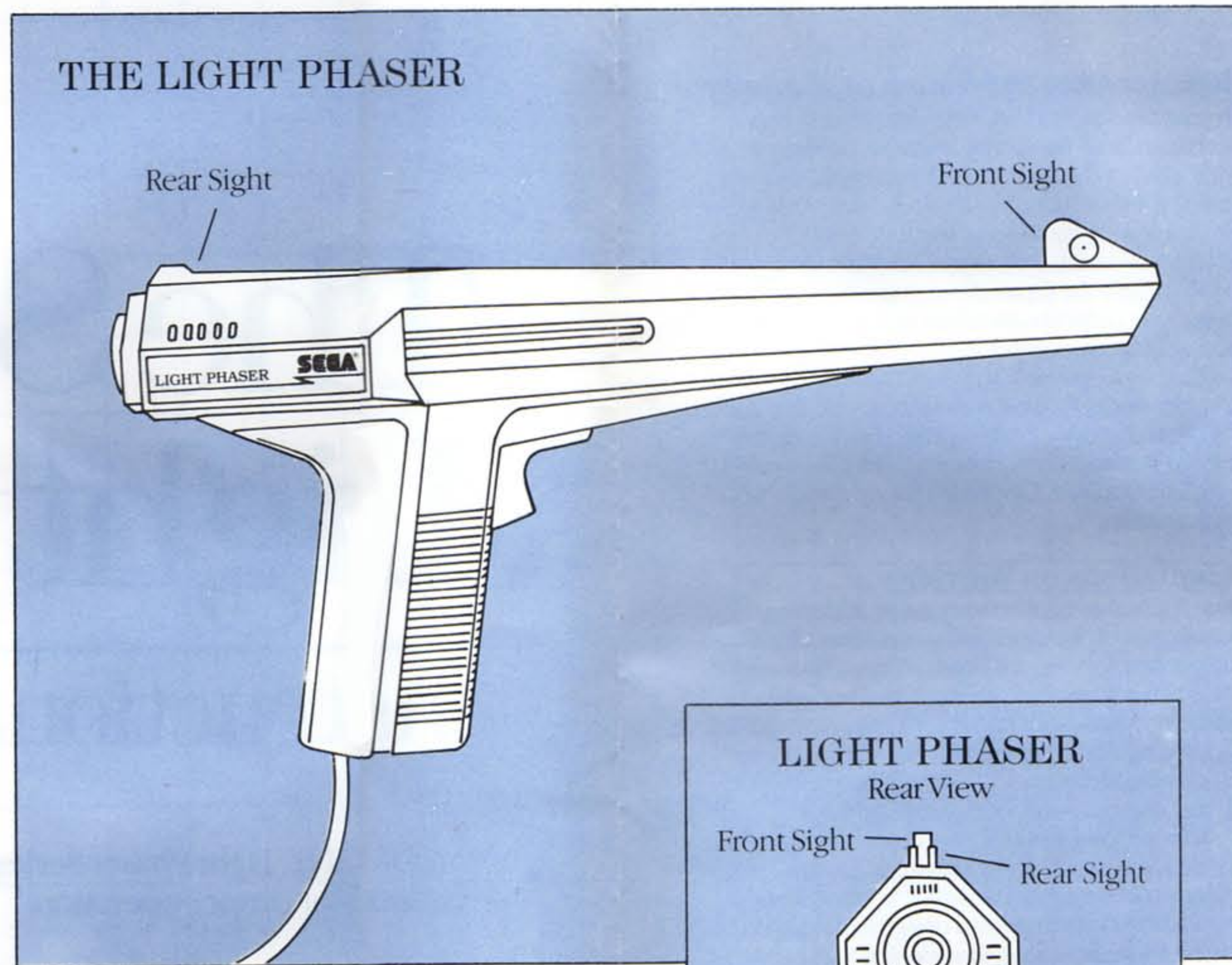

## Light Phaser Precautions

1. Television brightness and contrast may have to be somewhat increased, especially when using an older television.
2. Hitting a target is more difficult when shooting from a position too close, too far away, or off to the side.
3. The shooting range depends on the television's screen size. Recommended distance from television is 4 to 6 feet.
4. Do not expose the light phaser's lens to an intense light other than that of the television.
5. If the lens at the tip of the light phaser needs cleaning, use a soft cloth. Do not use cleaners such as benzene, alcohol, thinner, etc., for this purpose.
6. Do not drop or crush the light phaser.

IF YOU HAVE TAKEN ALL OF THE ABOVE PRECAUTIONS AND A PROBLEM STILL EXISTS, PLEASE CALL THE SEGA CUSTOMER SERVICE DEPARTMENT.  
Outside California call  
800-USA-SEGA  
Inside California call  
(415) 742-9300



## 90-DAY LIMITED WARRANTY

To validate the following 90-day limited warranty, your warranty card and sales slip or proof of purchase should be completed and returned to Sega within 10 days after date of purchase.

### 90-Day Limited Warranty

Sega of America, Inc. warrants to the original consumer purchaser that the Sega Light Phaser shall be free from defects in material and workmanship for a period of 90 days from the date of purchase. If defect covered by this warranty occurs during this 90-day warranty period, Sega will repair or replace the defective system or component part\*, at its option, free of charge.

This warranty does not apply if the defects have been caused by negligence, accident, unreasonable use, modification, tampering, or any other causes not related to defective materials or workmanship. Additionally, this warranty shall not be valid if the serial number of the Sega Light Phaser has been altered, defaced, or removed in any way.

To receive fast, reliable warranty service, call the Sega Customer Service Department at the following numbers:

Outside California State (800) USA-SEGA

Inside California State (415) 742-9300

Our Customer Service Department is in operation from 9:00 a.m. to 5:00 p.m. (Pacific Time), Monday through Friday. *Do not return your Sega Light Phaser to your retail seller.*

If the Sega technician is unable to solve the problem by phone, we will provide you with instructions on returning your defective system to us. The cost of returning the system to Sega's service center shall be paid by the purchaser.

Sega's service center is located at the following address:

SEGA OF AMERICA, INC.  
573 Forbes Blvd.  
South San Francisco, CA 94080

### Repairs After Expiration of Warranty

If your Sega Light Phaser requires repairs after termination of the 90-day warranty period, you may contact the Sega Customer Service Department at the number listed above. If the technician is unable to solve the problem by phone, he will advise you of the estimated cost of repair. If you elect to have the repair done, you will need to return the defective merchandise, freight prepaid, to Sega's service center with an enclosed check or money order payable to Sega of America, Inc. for the amount of the cost estimate provided to you by the technician. If, after inspection, it is determined that your merchandise cannot be repaired, it will be returned to you and your payment will be refunded.

### Limitations on Warranty

Any applicable implied warranties, including warranties of merchantability and fitness for a particular purpose, are hereby limited to ninety days from the date of purchase and are subject to the conditions set forth herein. In no event shall Sega of America, Inc. be liable for consequential or incidental damages resulting from the breach of any express or implied warranties.

The provisions of this warranty are valid in the United States only. Some states do not allow limitations on how long an implied warranty lasts or exclusion of consequential or incidental damages, so the above limitation or exclusion may not apply to you. This warranty provides you with specific legal rights. You may have other rights which vary from state to state.

\*Component covered under this warranty is the Sega Light Phaser (3050).

Sega Light Phaser is a trademark of SEGA OF AMERICA, INC.

Now, there are no limits.<sup>SM</sup>

**SEGA**<sup>®</sup>