

**INTRODUCING
THE WORLD'S FIRST
THREE-DIMENSIONAL
HOLOGRAPHIC
VIDEO GAME.**

*time traveler*TM

H O L O G R A MTM

SEGA

A GAME SO INCRE YOU WON'T BE YOU'VE P

IT DOESN'T LOOK, SOUND, OR PLAY LIKE ANY GAME YOU'VE EVER SEEN.

Never has there been a game so effective at transporting players to the very heart of video game action. Take its special effects for instance. They're right up there with Disney® and Lucas®. Sound? How about a theater-quality fully-digitized stereo sound track with full dynamic range and frequency response. But how does it play you ask? Well, for starters, the game's "characters" are real actors. That's right, no cartoon imitations of people, but real, in-the-flesh Hollywood pros. To add even more excitement, we've created some pretty intense computer generated, digitally-mastered special effects. And, thanks to a highly innovative micro-processor controlled laser disc, players appear to have full control over the actions of Marshal Gram, the game's key character.

Three dimensional images of Time Traveler's real actors appear on the Hologram stage.



WHY WE CAN'T SHOW YOU ANY MONITOR SHOTS.

But hold on, here comes the real fun. You've probably noticed that there aren't any monitor shots in this ad. Good reason. Time Traveler's action doesn't take place on a video monitor. Instead, images of real actors appear in three dimension on the Hologram™ stage located in front of the control panel. That's why we call Time Traveler™ a "Hologram Video Game". But don't

The patented Sega Hologram Video Game cabinet contains basic, proven, and easy to maintain components.

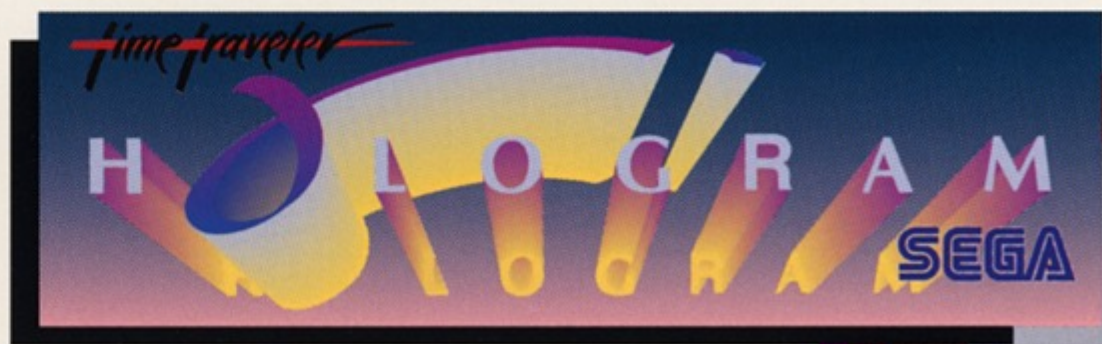
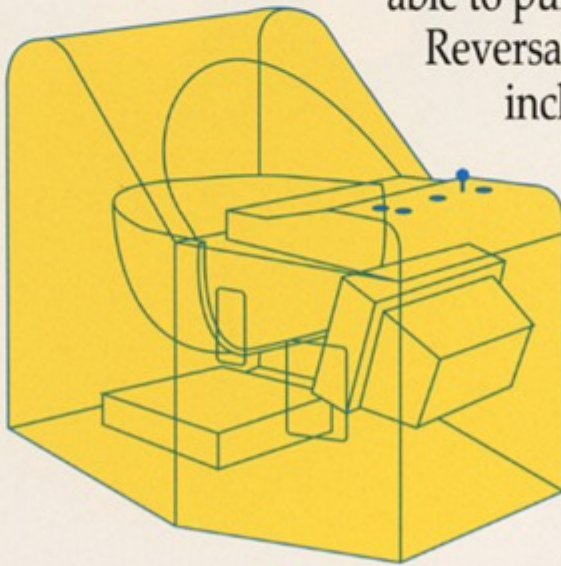

think that the game-play images that appear in this ad are anything like the breath taking images that you'll see in person. The images that appear in the game are three-dimensional and pictures that appear in ads are limited to two dimensions. It's something you really do have to see for yourself.

A 40" wide, back-lit, three-dimensional header assembly is an important option.

NEVER THE SAME GAME TWICE.

Chances are pretty good no one will ever play Time Traveler the same way twice. Not with play options such as travelling forward or backward through time, and being able to purchase a special game enhancer like the "Time Reversal Cube". Each of the Time Traveler eras include multiple action-filled episodes. With the number of options and play variables, there are a lot of reasons for players to keep coming back for more of Time Traveler.

AN INSIDE LOOK REVEALS SOME PLEASANT SURPRISES.

Expecting a lot of zoomy star wars technology only a rocket scientist could understand? Surprise. With the exception of a

TIME TRAVELER:™ DIBLY ADVANCED LIEVE IT UNTIL PLAYED IT.



patented black spherical mirror, the two piece Hologram Video cabinet doesn't contain anything you aren't already familiar with. A rugged, industrial grade Sony® 12" Laser Disc Player, a 20" Sony NTSC color television with **SONY** remote control, the spherical mirror, hard-wiring for a Bill Acceptor, and the usual electrical harnesses are all that are in there.



A rugged, industrial grade Sony 12" Laser Disc Player and a Sony NTSC color television are at the heart of the patented Hologram Video Game system.

WE'RE BACKING IT WITH A ONE YEAR WARRANTY ON MAJOR COMPONENTS.

You can throw away your "Out of Order" signs. Because of its simple architecture and proven components, the patented Time Traveler Hologram Video game is going to be one of your most dependable money makers.

HOLOGRAM VIDEO...GAMES WITH A FUTURE.

Time Traveler is the exciting, suspenseful, and delightfully entertaining story selected to introduce the phenomenal futuristic world of Hologram Video Games. Contact your Sega Distributor for more information on Time Traveler; the world's first three-dimensional, holographic video game!!

A STORY AS UNIQUE AS THE GAME ITSELF

Of course there's action, lots of it. To make sure that the Time Traveler story is as fresh as the technology that presents it, we added some healthy doses of drama, suspense, history, romance, and humor. There's the lovely Kyi-La, Princess of the Galactic Federation; the dashing and daring Marshal Gram; the evil renegade scientist Vulcor; the 300 lb. Femme Fatale; and an all-star supporting cast of space knights, ninja warriors, cavemen, cowboys, knights in armor, and punk rockers. Game play moves through time, from prehistoric caves to 26th century space ships as the handsome Marshal battles to save the Princess and prevent the destruction of the universe.

SEGA

Specifications and Dimensions.

Number of Players:	One or two players, alternating turns.
Type of Controls:	One joystick and two buttons.
Dimensions (Unboxed):	Height: 50" (127 cm). Width: 43" (109.2 cm). Depth: 45" (114.3 cm). Weight: 370 lbs. (167.83 KG).
Dimensions (Boxed):	Height: 56" (142 cm). Width: 53 ³ / ₈ " (136 cm). Depth: 46 ⁵ / ₈ " (118 cm). Weight: 410 lbs. (186 KG).
Power:	120VAC 300W.

Easily disassembles for passage through normal doorway.

Pre-wired for a Bill Acceptor.

Optional Equipment: "Holographic" Hologram Time Traveler Backlit Header Assembly.

Dimensions (Unboxed): Height: 13¹/₂" (34.3 cm).
Width: 41¹/₂" (105.4 cm).
Depth: 6" (15.2 cm).

Power: 120V 60W.

Design, specifications, and component suppliers subject to change without notice.

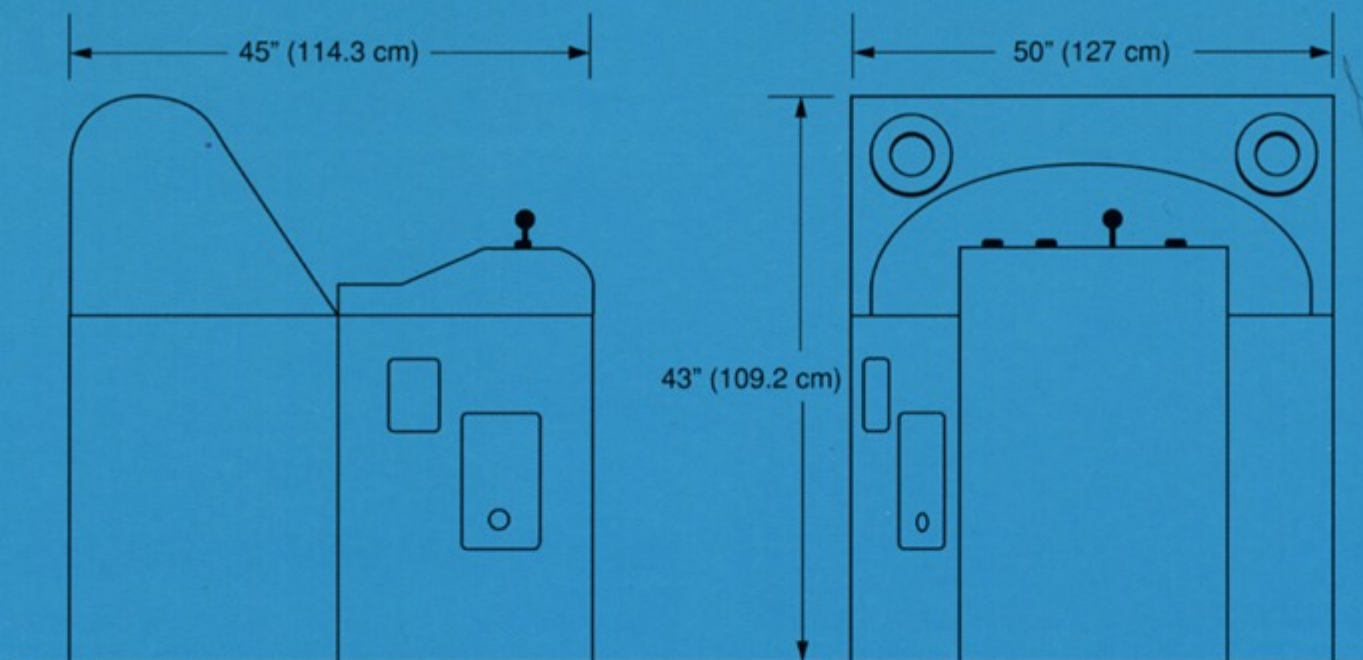

Sega Enterprises, Inc.
2149 Paragon Drive
P.O. Box 610550
San Jose, CA 95161-0550
(408) 435-0201

Sega Enterprises, Ltd
2-12, Haneda 1-Chome,
Ota-Ku, Tokyo 144 Japan
Tel.: (03) 743-7438
Fax.: (03) 743-5539
Tlx.: J22357 SEGASTAR

Sega Europe LTD.
Unit 6, Churchill Ct.
58 Station Road
North Harrow, MDD5X
HA2 7SA, England
Tel.: 81-863-7737
Fax.: 81-863-5354
Tlx.: 893501 SEGAUK G

Copyright 1991 Sega Enterprises, Inc. (U.S.A.)

SEGA