

## The Circuits

Here are the circuit layouts for all the countries you will race. Getting familiar with the courses is the first step to bringing home the championship trophy, so study them carefully!

7

RESULTS	
SENNIA A. SENNA	0:20:18
SNO - JONES	0:21:15
SUN - SPANIEL	0:21:22
SJA - J. JENSEN	0:22:00
SJA - ALFARO	0:22:05
SJA - J. HANSEN	0:23:00

YOUR POINTS: 56 PTS.  
SENNIA'S POINTS: 90 PTS.  
PASSWORD: ETRF-EZCA

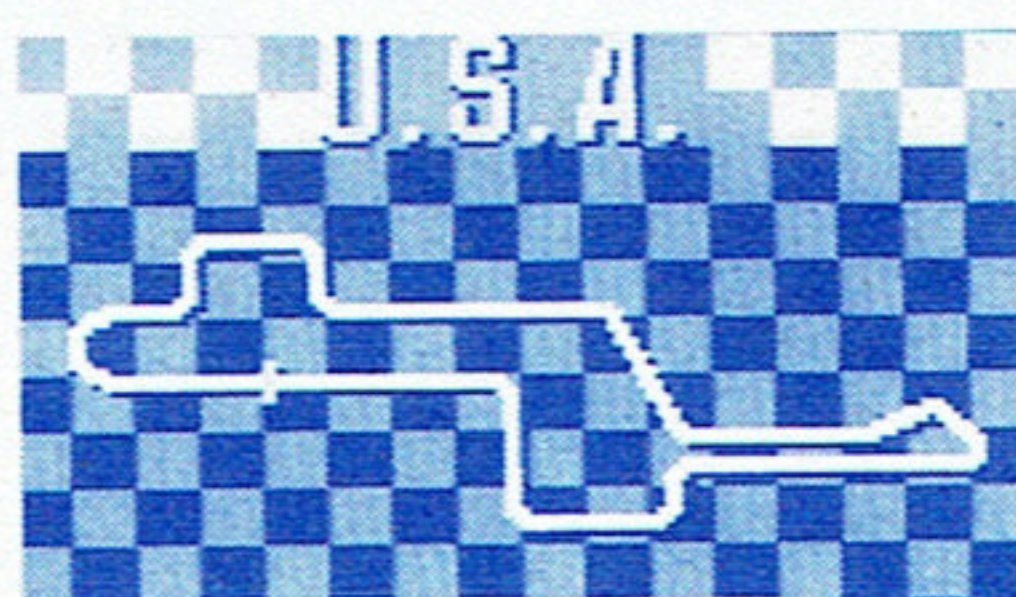

7



AYRTON SENNA'S  
**SUPER GP II**  
Monaco

SEGA MS

## The Checklist

- When using an automatic transmission, you will find that it isn't always necessary to use your brakes to slow down. Simply letting up on the gas pedal will cause your car to slow down, often just enough to get around that tricky curve without losing a lot of time.
- Curve indicators are very useful, but will not always appear at the same distance from the curves themselves. You must first rely on your own knowledge of where you are on the Circuit and what kind of curve is coming up, and use the indicators as reminders.

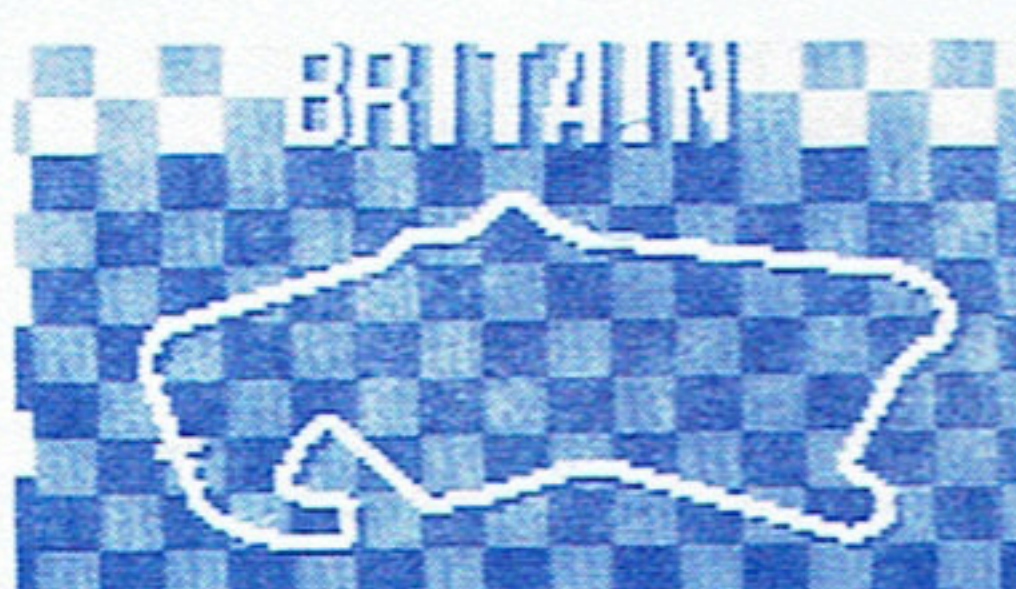

8

- Circuit maps (at the top right side of the screen in the Beginner mode) are useful references when you're just starting out, but there is no substitute for track experience. (Remember, in the Professional mode, you won't be able to see the maps).
- There is often a temptation to try and race through the entire course at full throttle, but that kind of technique doesn't win races, it loses them. There are curves which cannot be taken at top speed. Slowing down loses a little time, but crashing loses much more.



9

## Handling This Cartridge

This Cartridge is intended exclusively for the Sega System.

### For Proper Usage

- 1 Do not immerse in water!
  - 2 Do not bend!
  - 3 Do not subject to any violent impact!
  - 4 Do not expose to direct sunlight!
  - 5 Do not damage or disfigure!
  - 6 Do not place near any high temperature source!
  - 7 Do not expose to thinner, benzine, etc.!
- When wet, dry completely before using.
  - When it becomes dirty, carefully wipe it with a soft cloth dipped in soapy water.
  - After use, put it in its case.
  - Be sure to take an occasional recess during extended play.

**WARNING:** For owners of projection televisions. Still pictures or images may cause permanent picture tube damage or mark phosphor of the CRT. Avoid repeated or extended use of video games on large screen projection televisions.

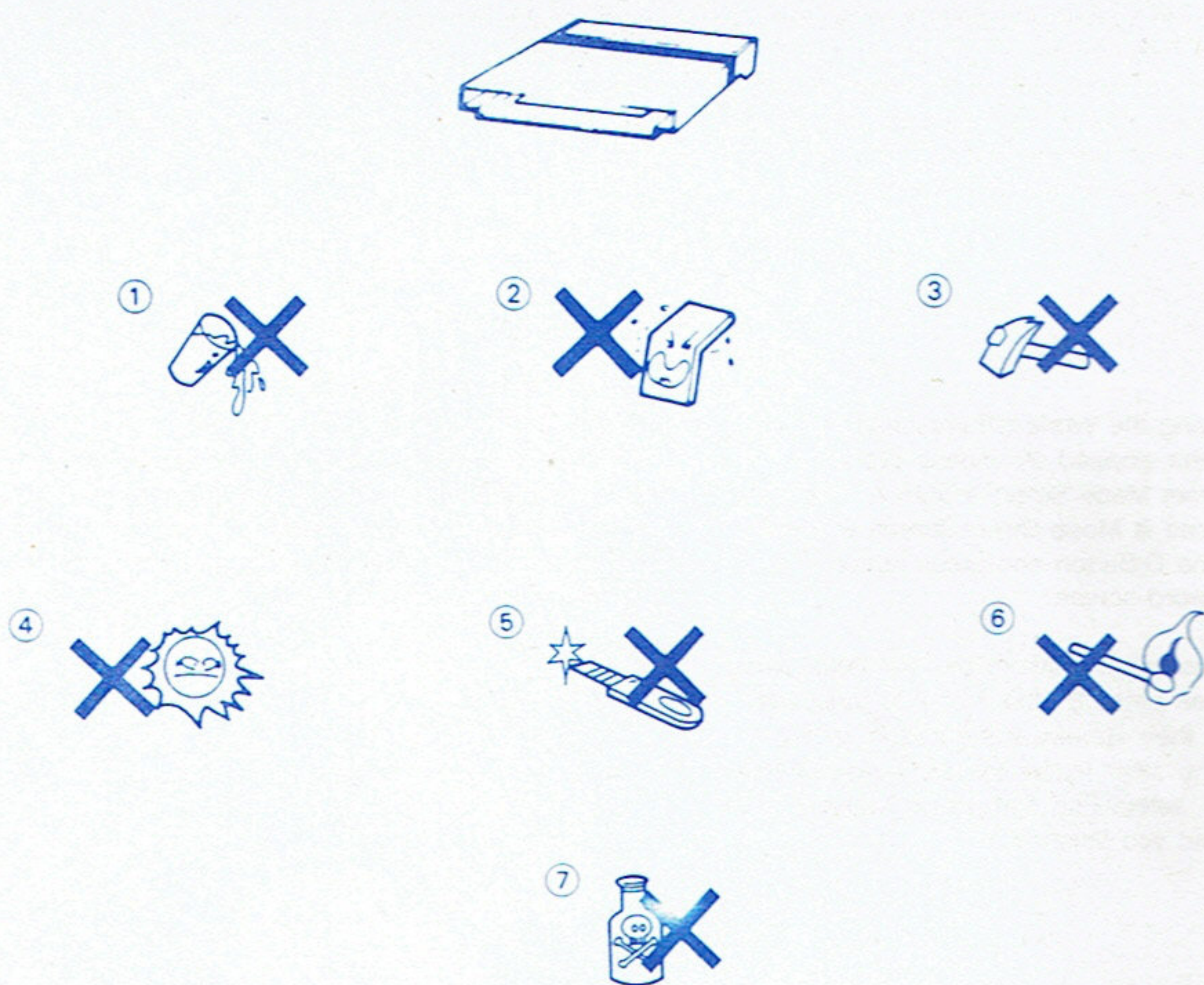

10

SEGA

Printed in Australia

11



## Starting Up

1. Set up your Sega Master System or Master System II as described in its instruction manual. Plug in Control Pad 1.
2. Make sure the power switch is OFF. Then insert the Sega cartridge into the Power Base.
3. Turn the power switch ON. In a few moments, the Title screen appears.
4. If the Title screen doesn't appear, turn the power switch OFF. Make sure your system is set up correctly and the cartridge is properly inserted. Then turn the power switch ON again.

**Important:** Always make sure that the power switch is turned OFF when inserting or removing your Cartridge.

**Note:** This game is for one player only.

- 1 Sega Cartridge
- 2 Control Pad 1

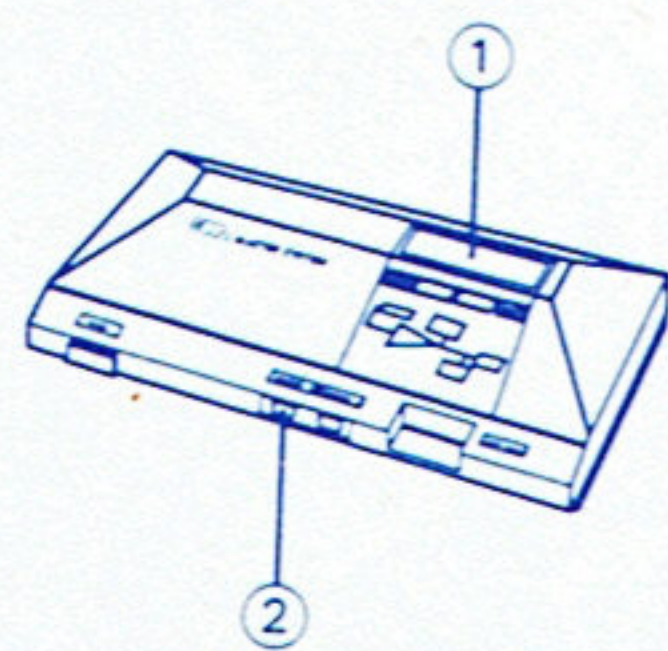

## Drivers to Your Cars!

The pit crew has finished checking your machine. Tires O.K. Gearbox O.K. The course is a little slick from showers earlier in the day, so your crew has given you the 45-degree foil for better traction. You roll into your position. You gun the engine. The light is green! A perfect start!

You are in the cockpit of a masterpiece of modern technology. Flash past your opponents at speeds over 325 k.p.h. in this thrilling F-1 race that pits your speed and dexterity against the most challenging tracks on Earth!

## Take Control!

### 1 Directional Button (D-Button):

- Press to cycle through selections in the options screens.
- Press to cycle through letters in the Password screen.
- Press left or right to turn.

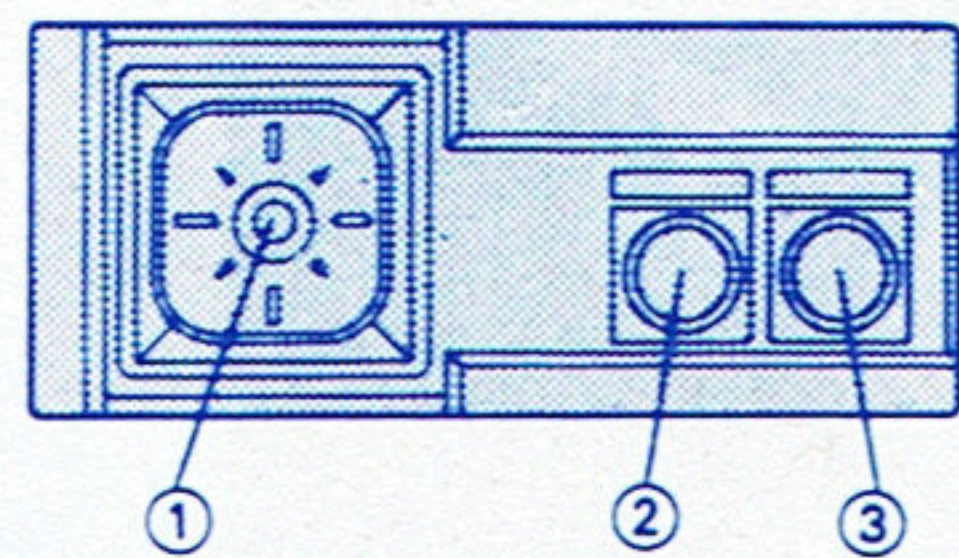

1

## Button Combinations

- When you want to leave the game screens; press the Pause Button on your Master System, and press Button 1 and Button 2 at the same time to return to the Course Select screen in the Free Practice mode, or to return to the Round screen in the World Championship mode.

## Start Your Engines!

Once you've inserted the cartridge and turned the power on, you'll see the Sega logo. After that, you will see the Title screen and the words "Press Start." If you don't do anything, a demonstration will start. To exit the demonstration, simply press Button 1 or 2. The Title screen will then reappear.

### 1 Title screen

Press Button 1 or 2 when you see the Title screen to start the game. You will then see the Mode Select Screen. You have the choice of starting your run for the World Championship, putting in some practice laps on the course of your choice in the Free Practice mode, or listening to any of the sounds and music in the game in the Option mode.

### 2 Mode Select screen



2

## Option

Press the D-Button up or down to select the category, then press left or right to cycle through the choices. Choose with either Button 1 or 2. Your choices are as follows:

**Level:** Choose Beginner or Professional. In the Beginner mode, a layout map of the course you're racing will appear at the top right side of the play screen. In the Professional mode, no map is displayed.

**B.G.M.:** Listen to any of the music in the game.

**S.E.:** Hear the various sounds used in the game.

**Voice:** Ayrtton Senna congratulates the winner!

When you want to exit the Option screen, simply cycle up to the Level option With the D-Button and press Button 1 or 2 to return to the Title screen.

### 3 Option screen



## Free Practice

Here's your chance to get a feel for the various tracks you will be driving on for the World Championship. The first screen you see will be the Course Select screen. At the top of the screen you will see the name of the country currently selected, and the layout of the track. Press the D-Button right to cycle forward through the tracks, and left to cycle back. Press Button 1 or 2 to access the Course Select Options screen. This screen gives you four options, explained below.

### 4 Course Select screen

**Message:** Ayrtton Senna gives you some pointers about the selected track. Reading these ahead of time may save you from some crashes, or give you the tip you need to win! Scroll forward through the message by pressing the D-Button down.

**Setting:** This screen allows you to pick the right configuration to fit the track. Each part you change will affect the way your machine handles, so it's best to play around to find which configuration fits the circuit best. Here are the choices:



3

**Mission:** Your choice of Automatic or Standard transmission. Using Automatic means you don't have to worry about shifting up and down, but Standard ensures you the maximum speed your machine can deliver.

**Gear:** Choose between Model-A or Model-B gearbox. Model-A will give you a higher maximum speed than Model-B, but it has a slower acceleration rate.

**Tire:** Take your choice of either B- or C-Comp. (Composition) tires. The B-Comp. are harder than the C-Comp., which means they are more durable, but because the C-Comp. tires are softer, they have better traction.

**Wing:** Choose between a Type-0 or Type-45 airfoil. Choosing 0-degrees means you achieve top speed, but the 45 degree foil gives you more stability when turning.

**Sample setting:** You're racing the track in Belgium. The number of curves to the circuit means you probably won't be able to drive flat out. You decide that the Model-B gearbox, with its faster acceleration rate will be more useful to you than Model-A's higher speed. You decide to go for the C-Comp. tires rather than the Type-45 airfoil, because the foil will slow you down too much, but you need the traction on the curves that the softer tires will give you.

### 5 Setting screen

**Start:** Now you're ready to get some track time in. Every lap you make in the Free Practice mode gives you experience you'll need to win the championship, so remember to take your practice runs as seriously as you would an actual race. The courses are the same, and so are the dangers!

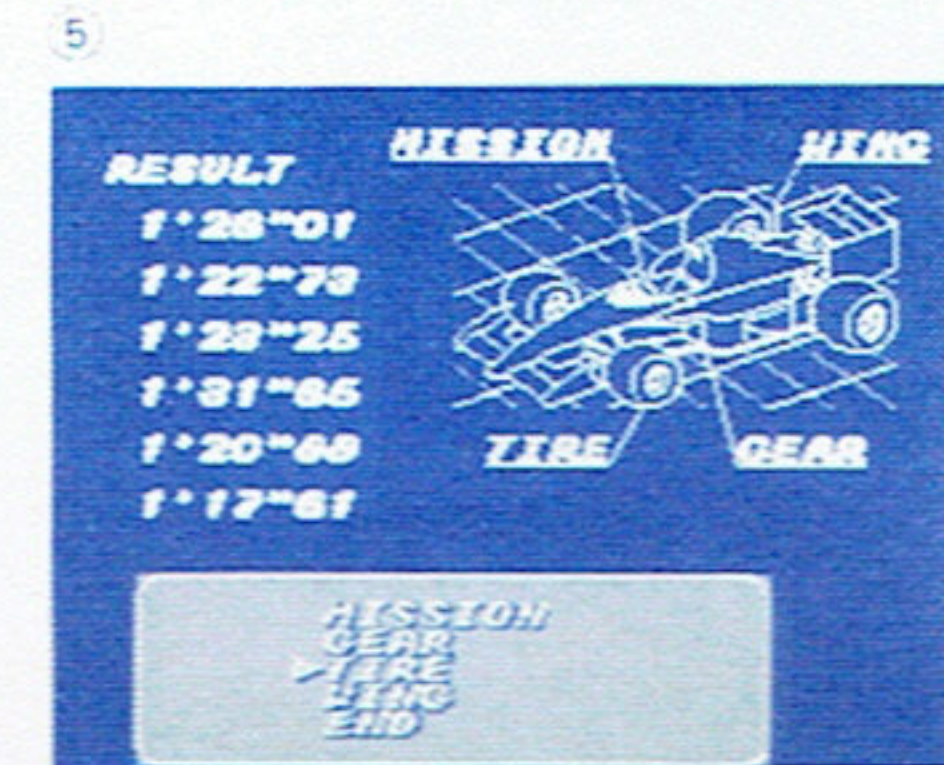

## Screen Signals

- 1 Lap Time
- 2 Best Lap
- 3 Track Layout
- 4 Position Indicator
- 5 Current Lap Time
- 6 Gear Indicator
- 7 Your Car
- 8 Speed

If you're using a standard transmission, use Button 2 to shift up, and Button 1 to shift down. For the automatic transmission, Button 2 is your gas pedal, and Button 1 your brake.

To return to the Course Select screen, press the Pause Button on your Master System and then press Buttons 1 and 2 simultaneously.

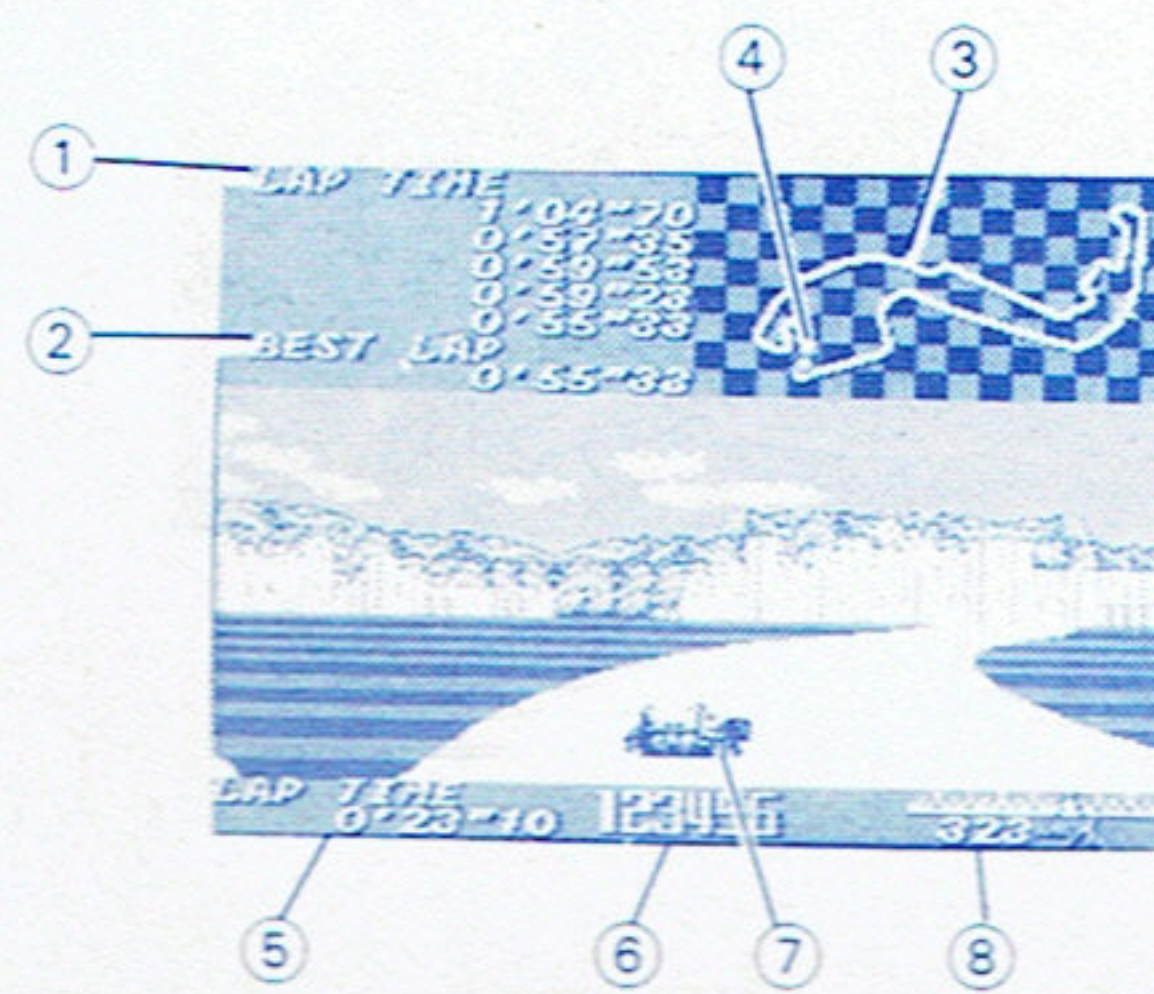

4

## End

If you decide to try another circuit, select End with the D-Button and press either Button 1 or Button 2 to leave the Course Select options screen; then cycle through the other choices by pressing the D-Button right or left.

When you want to leave the Free Practice mode altogether, press the Reset button on your Master system. When the Title screen appears, press Button 1 or 2 to return to Mode Select Screen A.

## The Green Light!

You've checked your machine and yourself out on the various tracks. You've found out which specifications work best for each circuit, where the tricky curves are, where the best places are to pass your opponents, and now you think you're ready to step into the winner's circle! First, go to Mode Select Screen A, and select World Championship with the D-Button, and enter your choice using Button 1 or 2.



Mode Select Screen B is displayed next. To race in the championship series from the start, select New Game with the D-Button, then press Button 1 or 2. Press either button again to see the Round screen, which includes the circuit layout, country name and round number. At the bottom of the screen, you will see the three options you have available.

### 6 Round screen

**Setting:** Here is your chance to reset your machine's configurations to fit the circuit. Your choices here are the same as those in the Free Practice mode; Mission, Gear, Tire and Wing (see page 14 for details about setting options). To return to the Round screen, select End with the D-Button, and enter your choice with Button 1 or 2.



**Qualify:** This is the time trial which determines your starting position in the race itself. A good qualifying time will put you near the front of the pack, and beating the track time will put you in the pole position (which gives you a much better chance of winning). If you don't run a qualifying race first, you will automatically be placed in the 12th (last) position which greatly reduces your chances of winning. Run the course as many times as you want, and once you feel you've achieved your best time, press the Pause Button on your Master System and press Buttons 1 and 2 simultaneously to return to the Round screen.

**Race:** You're suited up. Helmet on. Slip into your machine and take your assigned position. This is what it's all about, the run for glory.

The race screen is the same as that of the practice screens, with the following exceptions:

- 1 Comment Board
- 2 Time Elapsed
- 3 Laps Counter
- 4 Senna Position Marker
- 5 Your Position Marker

You will see a set of red lights at the top of the screen. When the lights switch to green, go! Go!

The number of laps you have taken and the total time elapsed will appear at the top left side of the screen. In the Beginner mode, the course layout will appear at the top right, with a marker showing your car's position (red) and the position of Ayrtton Senna (yellow). In the professional mode, the circuit isn't displayed — you rely on experience you've picked up in the practice runs.

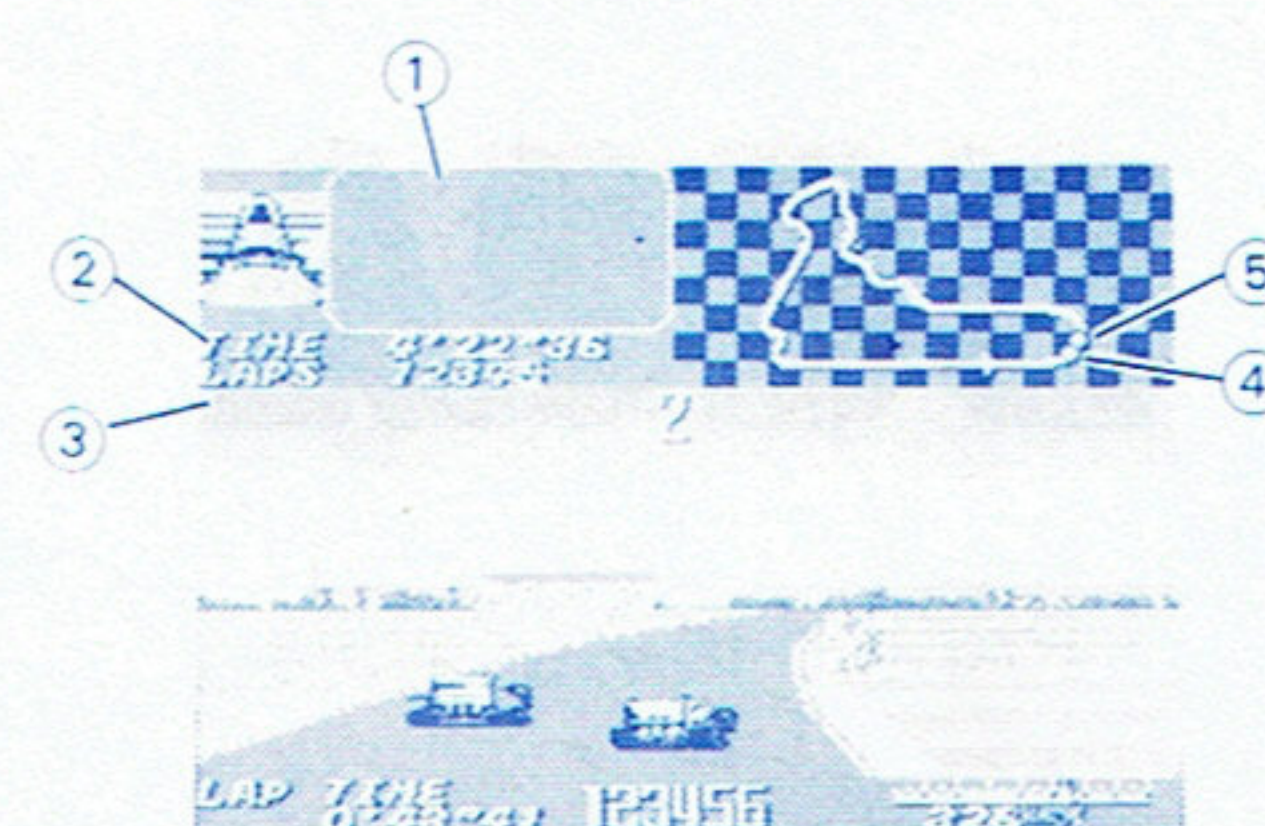

5

## The Checkered Flag!

The World Championship is a series of 16 races of various lengths, spanning the globe. Each track has its own characteristics, ranging from relatively easy high-speed circuits to dangerous curve-filled courses which take all your skill and concentration to maneuver through.

Once you finish a race, a screen will appear, showing the race's results. The top 6 drivers and their times are shown, as well as the current point total for you and Ayrtton Senna. Points are awarded as follows:

1st Place	10 points
2nd Place	6 points
3rd Place	4 points
4th Place	3 points
5th Place	2 points
6th Place	1 point

At the bottom of the screen, the password for the next race will be shown. Don't forget to write down the password, in case you want to continue playing from that point later. After noting the password, you can go on to the next race by pressing Button 1 or 2. The next Round screen will then appear.

## Passwords

To continue playing the World Championship series from any point you stopped at, choose World Championship from Mode Select screen A. The next screen you will see is Mode Select screen B. Select Password with the D-Button and press button 1 or 2 to see the Password screen.

To enter your password, move to the first letter using the D-Button, then press Button 1 or 2 to input the letter, which will then appear at the bottom of the screen. Select the other letters the same way. When you are finished, select End and press Button 1 or 2 to enter the round you finished at.



6