

Dreamcast™

GP	G	A	T
73	20	24	44
82	20	47	
71	20		
232			

SEGA
SPORTS™

NHL 2K2

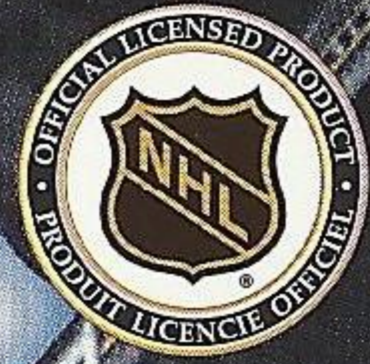

EVERYONE
E
CONTENT RATED BY
ESRB

51182

WARNINGS Read Before Using Your Sega Dreamcast Video Game System

CAUTION

Anyone who uses the Dreamcast should read the operating manual for the software and console before operating them. A responsible adult should read these manuals together with any minors who will use the Dreamcast before the minor uses it.

HEALTH AND EPILEPSY WARNING

Some small number of people are susceptible to epileptic seizures or loss of consciousness when exposed to certain flashing lights or light patterns that they encounter in everyday life, such as those in certain television images or video games. These seizures or loss of consciousness may occur even if the person has never had an epileptic seizure.

If you or anyone in your family has ever had symptoms related to epilepsy when exposed to flashing lights, consult your doctor prior to using Sega Dreamcast.

In all cases, parents should monitor the use of video games by their children. If any player experiences dizziness, blurred vision, eye or muscle twitches, loss of consciousness, disorientation, any involuntary movement or convulsion, **IMMEDIATELY DISCONTINUE USE AND CONSULT YOUR DOCTOR BEFORE RESUMING PLAY.**

To reduce the possibility of such symptoms, the operator must follow these safety precautions at all times when using Dreamcast:

- Sit a minimum of 6.5 feet away from the television screen. This should be as far as the length of the controller cable.
- Do not play if you are tired or have not had much sleep.
- Make sure that the room in which you are playing has all the lights on and is well lit.
- Stop playing video games for at least ten to twenty minutes per hour. This will rest your eyes, neck, arms and fingers so that you can continue comfortably playing the game in the future.

OPERATING PRECAUTIONS

To prevent personal injury, property damage or malfunction:

- Before removing disc, be sure it has stopped spinning.
- The Sega Dreamcast GD-ROM disc is intended for use exclusively on the Sega Dreamcast video game system. Do not use this disc in any thing other than a Dreamcast console, especially not in a CD player.
- Do not allow fingerprints or dirt on either side of the disc.
- Avoid bending the disc. Do not touch, smudge or scratch its surface.
- Do not modify or enlarge the center hole of the disc or use a disc that is cracked, modified or repaired with adhesive tape.
- Do not write on or apply anything to either side of the disc.
- Store the disc in its original case and do not expose it to high temperature and humidity.
- Do not leave the disc in direct sunlight or near a radiator or other source of heat.
- Use lens cleaner and a soft dry cloth to clean disc, wiping gently from the center to the edge. Never use chemicals such as benzene and paint thinner to clean disc.

PROJECTION TELEVISION WARNING

Still pictures or images may cause permanent picture tube damage or mark the phosphor of the CRT. Avoid repeated or extended use of video games on large-screen projection televisions.

SEGA DREAMCAST VIDEO GAME USE

This GD-ROM can only be used with the Sega Dreamcast video game system. Do not attempt to play this GD-ROM on any other CD player; doing so may damage the headphones and/or speakers. This game is licensed for home play on the Sega Dreamcast video game system only. Unauthorized copying, reproduction, rental, public performance of this game is a violation of applicable laws. The characters and events portrayed in this game are purely fictional. Any similarity to other persons, living or dead, is purely coincidental.

TABLE OF CONTENTS

Introduction	2
Starting the Game	2
Control Summary	4
Menu Controls	4
Offense	5
Defense	8
Basic (Goalie)	9
Advanced (Goalie)	10
Fighting	11
Game Setup	12
Selecting Your Teams	13
Coaching Strategies	13
Chris Drury Bio	14
Pause Menu	20
Replay Controls	21
Settings	22
Options	23
Saving / Loading	23
Credits	24
Notes	27

INTRODUCTION

YAWL READY FOR THIS?

It's time to lace up your skates and head back to the ice arena. NHL 2K2 explodes onto the Sega Dreamcast to complete the phenomenal series of 2K2 sports games. And hockey has never been this good.

All the hits, all the speed, all the shots, and all of the saves - basically everything that you've come to expect from Sega. All of the realism, controls, and amazing graphics are waiting for you inside.

Do you want to play a full season? How about a half season? Just the playoffs? Or what about a tournament with your friends? It's all there. Spy the puck carrier along the boards and deliver a bone crunching check or hit the open man with a beautiful pass for a perfect one-timer.

So what are you waiting for? All of the great hockey match-ups are right there at your fingertips. Lace up your skates and get your game face on. This is hockey, and this is NHL 2K2.



STARTING THE GAME

NOTE: Sega Sports™ NHL 2K2 is a one to four-player game. Before turning the Dreamcast Power ON, connect the controller(s) or other peripheral equipment into the control ports of the Dreamcast. To return to the title screen at any point during gameplay, simultaneously press and hold the A, B, X, Y, and START buttons. This will cause the Dreamcast to soft-reset the software and display the title screen.

STARTING THE GAME

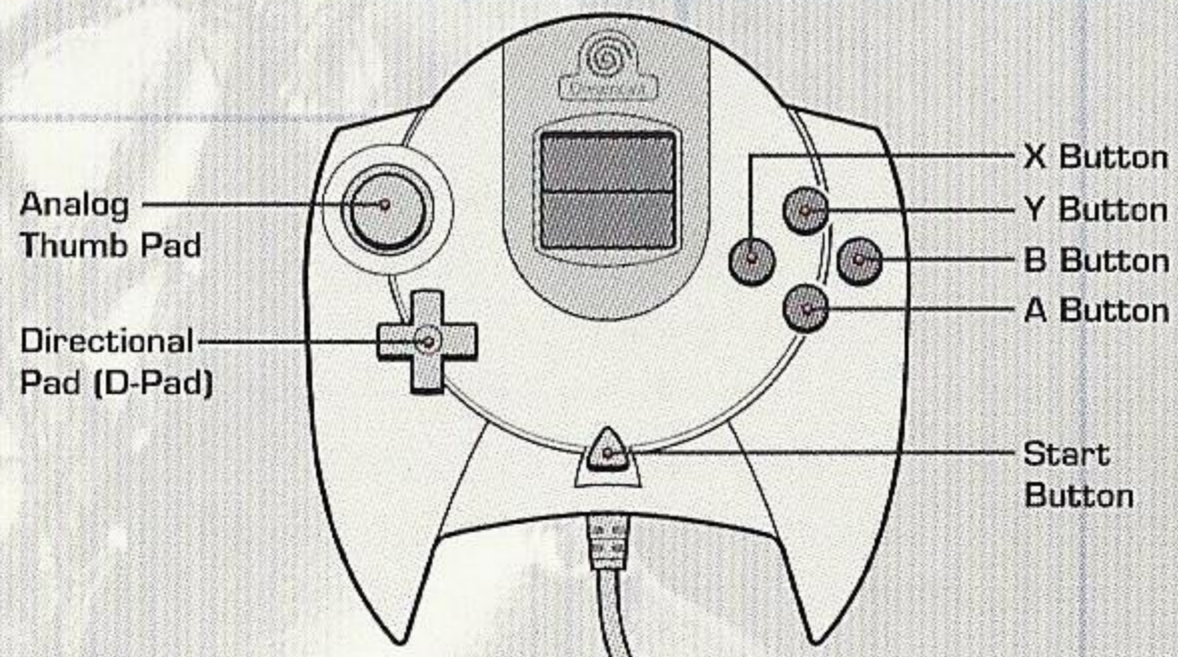
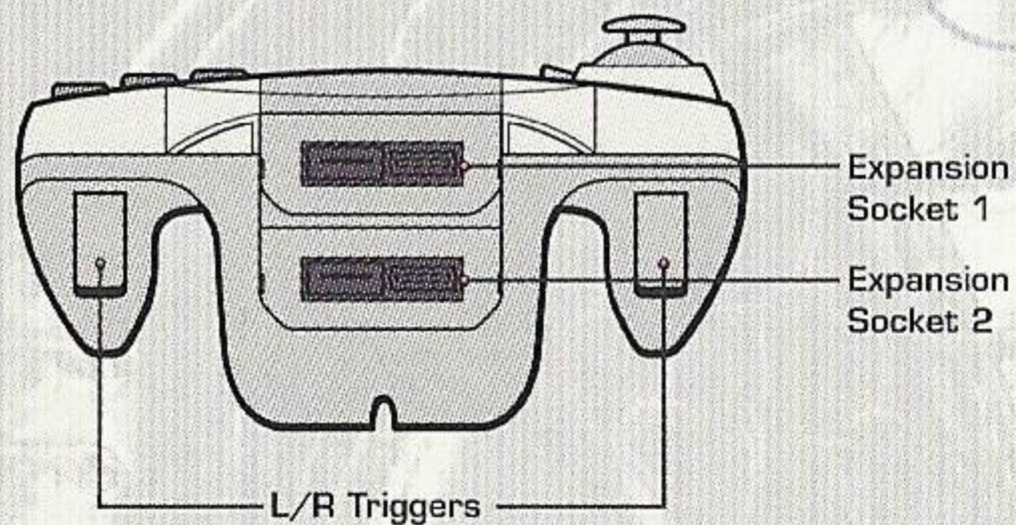

Keyboard

It's easy to use. Simply plug into a Dreamcast controller port.

Key spacing, size and tactile feedback same as the finest keyboards.

Compatible with Dreamcast internet browser.

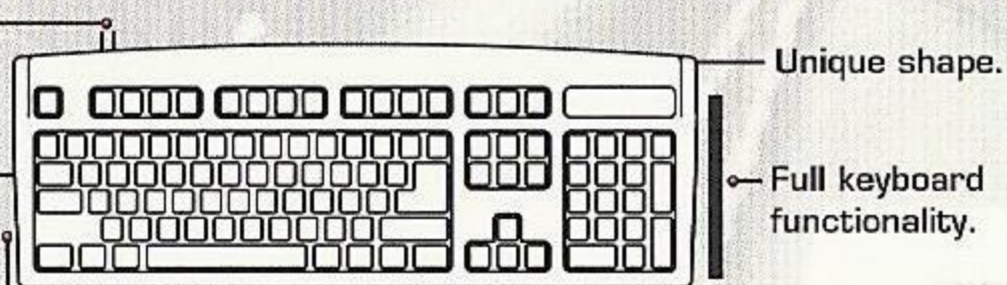

Virtual Memory Unit

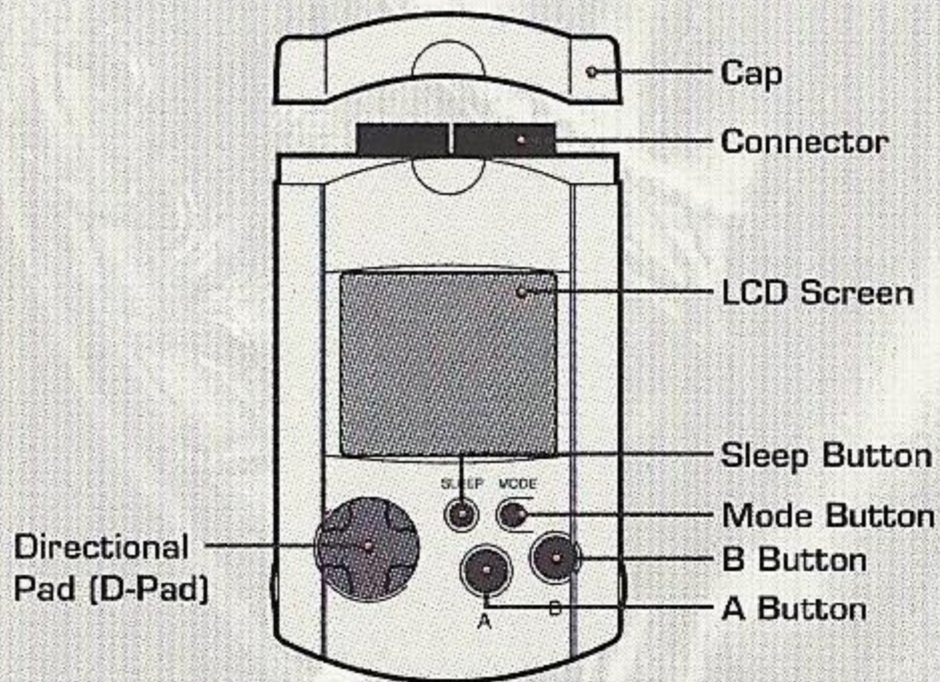

Jump Pack

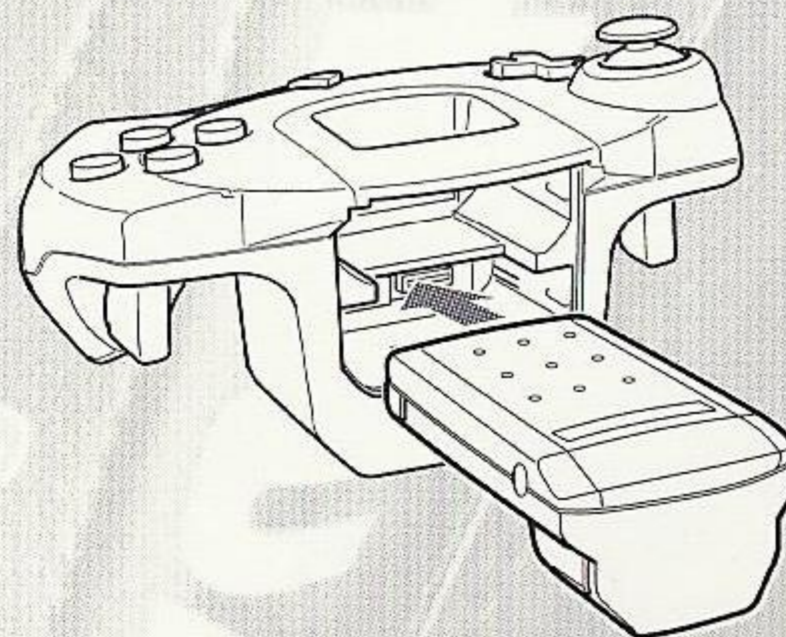

MENU CONTROLS

CONTROL SUMMARY

NHL 2K2 is designed with analog functionality in mind. The SEGA Dreamcast analog controls provide a fuller range of motion and add to the overall depth of the game. Go to Settings -> Controller to view and configure the controller setup. There are Basic controls for the new player but added flexibility is given to the more experienced hockey player with Advanced Controls.

To highlight and select specific menu items, press the Analog Stick (or D-pad) in the direction of the menu item until it highlights, and press the A button. If you have questions when viewing most menus and screens, press the Y button for Command help.

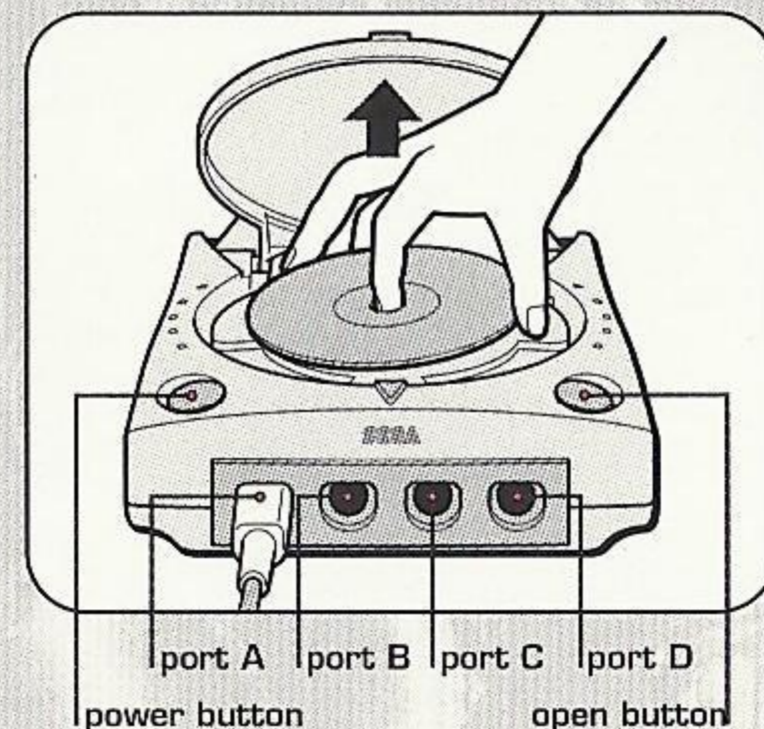

MENU CONTROLS



Button

Analog Stick (or D-Pad)

A

B

X

Y

Action

Highlight menu options

Select / Scroll through the highlighted selections

Cancel selection / return to previous

Special Menu Functions

Command Help Menu

OFFENSE

Here's a break down of the standard controls when you or one of your teammates has the puck and you are on offense. Use the Deke, Speed Burst and Sidestep to elude the defenders and put the shot on net. One of your best chances to score is the One-Timer. Get the pass to your teammate and shoot it as soon as you get the puck. The misdirection can get the goalie out of position for an open look at the net.

BASIC OFFENSE

Offensive Moves with the Puck

Button	Action
Y	Deke / Dump
X	Shoot
B	Speed Burst
A	Pass
L Trigger	Protect / Sidestep

Offensive Moves without the Puck

Button	Action
Y	Deflection
X	One-Timer / Hook
B	Speed / Check
A	Change Players
L Trigger	Sidestep

Coach's Corner: Use your teammates

Hockey isn't played one on five - it's a team game so use the rest of your players. Crisp passing will help you find the man with the best look at the goalie, and the best chance of putting the biscuit in the basket.

Coach's Corner: Shoot the puck

When you get the puck in the offensive end of the arena, shoot the puck. Wrist shots, slap shots, wrap-arounds, and one-timers; the more shots you put on goal the better your chances are of scoring.

Advanced Offense

Offensive Moves with the Puck

Button

Y

Y + L Trigger

X

X + L Trigger

B

B + L Trigger

A

A + L Trigger

R Trigger

L Trigger

Action

Dump

Deke

Wrist Shot / Snap Shot

Slap Shot

Protect Puck

Side Step

Pass

Flip Pass

Speed Burst

Modify Buttons



Coach's Corner: Controlling the shot

Direct your shot by using the analog stick while shooting the puck. Look where the goalie is setting up and use it to your advantage. If he has flopped onto the ice, press up on the analog stick while shooting to send the puck high. If he's still on his feet, you can try going five hole (between his legs) by pressing down on the stick while shooting.

Offensive Moves without the Puck

Button	Action
Y	Deflection
X	One - Timer
X + L Trigger	One - Timer
B	Check
B + L Trigger	Side-step
A	Change Skaters
A + L Trigger	Control Goalie



Coach's Corner: Two Line Pass

You've got a teammate flying down the right wing and you make the pass but when he touches the puck, the referee whistles the play dead. You have to be careful when you make long passes in the NHL. If the puck crosses a blue line and the red center line without being touched by another player, it is considered a two line pass. (When you do this the play will stop and you will have to face-off where the two line pass originated).

DEFENSE

You have to play a strong defense to win at hockey. Check the other team's skaters early and often. The other team can't score if you keep them out of your zone.

BASIC DEFENSE

Button	Action
Y	Block Shot / Dive
X	Poke Check / Hook
B	Speed Burst / Check
A	Change Players

ADVANCED DEFENSE

Button	Action
Y	Block Dump / Knee
Y + L Trigger	Block Shot / Dive
X	Poke Check
X + L Trigger	Hook
B	Check
B + L Trigger	Side Step
A	Change Players
A + L Trigger	Goalie



Coach's Corner: Dumping the puck

When your players are in need of a line change and are having trouble getting the puck out of their zone, or if you are trying to keep the puck in the opposing team's zone, utilize the Advance controls to take advantage of the "dump" and "dump block" features. On offense, you can dump the puck by pressing the Y button once you gain control of the puck in your zone. On defense, with a defender near the boards, pressing the Y button will cause your defender to snug up against the boards to block the opposition's dump attempt.

GOALIE CONTROLS

You can let the A.I. control the goalie for you, or with Advanced controls you can step in and save the shots on your own - the ultimate challenge. Strap on the pads and see if you can make all the big saves.

BASIC

Goalie with the Puck

Button

Y

Action

Cover

X

Clear

B

Leave Puck

A

Pass



Goalie without the Puck

Button

Y

Action

Save / Stance

X

Poke Check

B

Check / Slash

A

Change Players

ADVANCED

Goalie with the Puck

Button	Action
Y	Cover
X	Clear
B	Leave Puck
A	Pass

Goalie without the Puck

Button	Action
Y	Save
Y + L Trigger	Goalie Style
X	Poke Check
X + L Trigger	Poke Dive
B	Check
B + L Trigger	Slash
A	Change Players
R Trigger	Speed Burst

Coach's Corner: Control the rebounds

A lot of times the goalie will make the initial save, but the puck will ricochet off his pads. The puck invariably ends up in the hands of the attackers and the second shot sneaks past the goalie. When you're on offense make sure you follow your shot in to the goal to try for that second chance. When you're on defense, check the shooter and get to the rebound as quickly as you can.

FIGHTING

With all of the physical play, it is understandable that tempers flare. As the game gets more physical the chances of a fight increase. When they do drop the gloves, the players will square off and you'll have the chance to duke it out. Don't get too excited if you win though - both players will leave the ice with a 5 minute major penalty.

Button

X

B

A

Action

Punch

Grab

Duck / Avoid



Coach's Corner: Get in control of the game



When you see this icon on screen, don't bother trying to change lines, aggressiveness or face-off formation. This icon indicates you are locked out. The home team is allowed the last change before a face-off. See page 13 for Coaching Strategies controls.

GAME SETUP

There are several game modes you can play in NHL 2K2: Quick Start, Exhibition, Season, Playoffs, and Tournament. Here are all of your options from the main menu.

Exhibition

Pick any two teams and go at it one on one. This is a great way to practice before heading into your season or when you're playing against a friend.

Season

Get ready for either a full 82 game or half 42 game season. Guide your team through the regular season and then on to the playoffs if your team is good enough.

Playoffs

Do you want the exciting chase of the Stanley Cup but without the grueling regular season? Then select playoffs, pick your team and see if you can lead them to the Championship series.

Tournament

Set up a 4, 8, or 16 team tournament.

Credits

View the names of the people that created NHL 2K2.

Quick Start

Jump right into the action.

Rosters

Trade players from team to team to adjust your favorite team's roster.

Records

View your user created records.

Settings

Adjust the game settings. See page 22 for a further explanation.

Coach's Corner: Penalty Killing

When your team makes a mistake and gets whistled for a penalty, the offending player will get sent to the penalty box. With player(s) in the penalty box, you'll have to play one or two men down. Your objective during a penalty killing situation is to keep the puck out of your zone. Don't worry about trying to score - just get control of the puck and dump it down the ice. You're trying to kill time so you can get back to full strength.

SELECTING YOUR TEAMS



Once you've selected the type of game you want to play, you will be brought to a screen like this one. This is where you get to select your team. Push the analog stick left to choose the Away team, or push right on the analog stick to choose the Home team. Use the L and R triggers to cycle through the teams and then press the START button to make your selection.

COACHING STRATEGIES

With NHL 2K2 you get to control the offensive and defensive tactics of your team by implementing these coaching strategies. Use the controls listed below to cycle through the styles of play.

Button	Action
D-Pad Left	Previous Play
R Trigger + D-pad Left	Less Aggressive
D-Pad Right	Next Play
R Trigger + D-pad Right	More Aggressive

Chris Drury

Do you know Chris, one of the NHL's rising stars? Chris Drury exploded onto the scene in the 1998-99 season with 20 goals, 24 assists - good enough stats to land him the Rookie of the Year honors. So what did he do for an encore? The young Avalanche center poured in 20 more goals and 47 assists in his sophomore season. Then during his third season, he was a big key to leading Colorado to the Stanley Cup with 24 goals and 41 assists.

Shoots: Right
Height: 5' 10"
Weight: 185 lbs
Born: August 20, 1976
Hometown: Trumbull, Connecticut

Season	Games	Goals	Assists	Points	PIM
1998-99	79	20	24	44	62
1999-00	82	20	47	67	42
2000-01	71	24	41	65	47
Totals	232	64	112	176	151



CAREER HIGHLIGHTS

- 1999 Calder Memorial Trophy winner (given to the Rookie of the Year)
- Played College Hockey for Boston University where he is the all-time leading goal scorer with 113
- Was the winning pitcher in the 1989 Little League World Series

OFFENSE

Breakout (puck is in your zone)

- Board Good for defeating a team that is aggressively forechecking.
- Positional Use this when your skaters aren't as skilled as the defense.
- Free Flow Use this when you have good skaters on the ice and the defense is not putting on a lot of pressure.

Move Out (puck is in the neutral zone)

- Positional Good for a Dump and Chase attack.
- Regroup Take a moment to reset your offense.
- Criss Cross Get your skaters running across ice to build up speed.

Offensive Zone

- Positional The Forwards will come straight across the ice.
- Triangle The Forwards will be on the same side of the net, cycling the puck looking for the open shot.
- Overload Get a player in front of the net. If you've got big players, stand one of your big men up in front of the goalie to pick up the rebounds.

DEFENSE

Forecheck (puck is in the opponent's zone)

- 1 - 4 A conservative attack where only the center is forechecking.
- 2 - 2 - 1 This is an aggressive attack, a good play for big teams.
- 1 - 1 - 3 Use the Zone forecheck to slow down faster teams.

Neutral Zone

- 1 - 1 - 3 This aggressive attack will really press for turnovers.
- 1 - 2 - 2 This conservative attack is best used to slow down faster teams.
- 2 - 1 - 2 A zone trap is an advanced defensive technique designed to force the puck to the outside.

Defensive Zone

- Zone This is a safe defense to call, except when you are outmanned in a penalty killing situation.
- Box and 1 Another zone defense, this one keeps a man in the slot.
- 1 - 2 - 2 This is a combination of zone and man coverage.

FACE-OFFS

- Offensive Looks for the immediate shot off the break or an immediate break down the ice.
- Normal Good when face off is taking place in the neutral zone.
- Defensive The defensemen will drop back and cover the net on the break.



SPECIAL TEAMS

Power Play

- 2 - 1 - 2 A balanced attack when you have a man advantage.
- Funnel Players attack the net, a good offense to pick up long slap shots and rebounds.
- Wing Off Side This attack looks for the one-timer.

Penalty Kill

- Box The defenders take positions in a square covering as much ice as possible.
- Diamond This offers more protection right up the middle.
- Triangular A good defense when you have two men in the penalty box.

LINE CHANGES

The longer your players are on the ice, the more fatigued they become. Your best chance at winning the game comes when you keep your players fresh. Use the controls listed below to get new players out onto the ice. Don't call for a line change when the other team is attacking your goal. Wait for your players to cross center ice, then dump the puck into the offensive zone and switch out your players.

Button

D-Pad Up

R Trigger + D-Pad Up

D-Pad Down

R Trigger + D-Pad Down

Action

Next Offensive Line

Previous Offensive Line

Next Defensive Line

Previous Defensive Line

NOTE: With Power Play or Penalty Kill lines on the ice, pressing up or down on the D-Pad will change the entire line (3, 4, or 5 players depending on the situation).

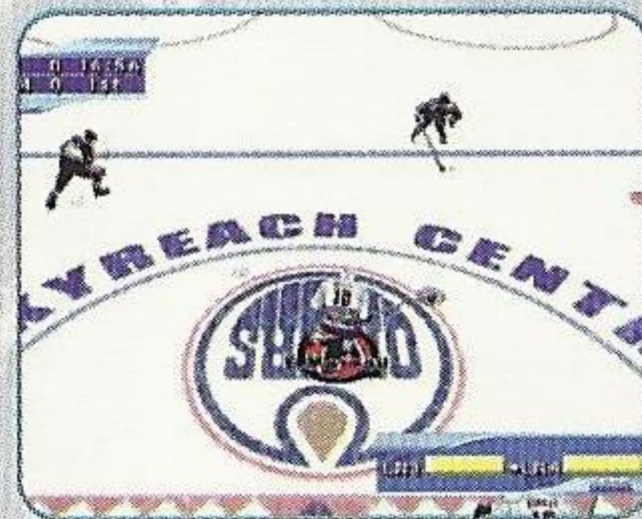

Coach's Corner: Be careful when you're passing

Be careful when you pass the puck. Try to avoid passing it from one side of the ice to the other. When you make a long cross ice pass, the chances of a defender skating in between and picking it off are high. This is how a lot of breakaway opportunities happen.

PAUSE MENU

Press the START button during the game to bring up the Pause Menu. From here you can select from one of the following options:

- Replay:** Review the previous play again and again.
- Stats:** Break the game down with all of the numbers - shots, saves, hits, and much more.
- Lines:** Edit your lines to mix up your player combinations. Get the hot goal scorer up onto your number one line to maximize his playing time.
- Time Out:** You don't see many time outs in hockey, but if your team needs a break you can call one. It is the perfect way to get your best players a little breather at the end of a period without having to sit them for a shift.
- Quit:** Leave the game and go back to the main menu. The game will ask you to confirm that you really want to quit before leaving the game.
- Camera:** Select from one of the many camera angles available in the game. Select the one that gives you the best view of the game.
- Pull Goalie:** You can always pull your goalie to get an extra skater out on the ice. Do this when you are down a goal and the face-off is in your opponent's end of the ice.
- Controller:** Change which team you are controlling.
- Settings:** See page 22 for the details of this sub - menu.

REPLAY CONTROLS

Want to see that beautiful one-timer again? Then bring up the Replay feature of NHL 2K2 from the pause menu to view it again and again. Change the angle, zoom in or zoom out and you can see the shot sneak past the goalie. It's like you're in charge of your own highlight reel.



Button	Action
A	Play at real time speed
B	Zoom Out
X	Zoom In
Y	Replay Panel ON / OFF
L Trigger	Rewind (analog)
R Trigger	Fast forward (analog)
D-Pad	Moves aim indicator
Analog Stick Up	Pan High
Analog Stick Down	Pan Low
Analog Stick Left	Pan Left
Analog Stick Right	Pan Right

NOTE: While moving the aim indicator, you can also "lock on" to any player to follow them throughout the entire replay. To do so, simply move the aim indicator directly on top of whatever target you wish to track.

SETTINGS

When you select Settings from the Pause Menu, you will go to this sub-menu. From here you can adjust the following:

- Presentation:** Change all of the audio and visual cues in the game. You can adjust player indicators, turn the offside indicator on and off, change the sound, volume and in game commentary. Customize your NHL 2K2 playing experience to best suit your liking.
- Controller:** Take a quick look at the current controller configuration (which buttons do what). Also, toggle between Basic and Advanced Controls.
- Options:** View the Options Menu. See Page 23.
- Exit Settings:** Return to the previous menu.

Coach's Corner: Icing

Icing occurs when a team passes, shoots, or deflects the puck across the red center line and then past the red goal line in that team's offensive zone without being touched by another member of that team. With NHL Icing rules, the penalty is not called until the defensive team touches the puck after it crosses the red goal line. If the offensive team touches the puck before the defensive team, icing is not called. With International Icing rules, the penalty is called as soon as it crosses the red goal line.

OPTIONS

Skill Level:	Rookie / Pro / All-Star
Game Speed:	Slow / Medium / Fast / Lightning
Icing:	Off / Auto / NHL / International
Offside:	Off / On
Two-Line Pass:	Off / On
Penalties:	Adjust the frequency of penalties
Fighting:	Adjust the frequency of fights
Away Line Changes:	Auto / None / Manual
Away Coaching Changes:	Auto / Manual
Away Goalie:	Auto / Manual
Home Line Changes:	Auto / None / Manual
Home Coaching Changes:	Auto / Manual
Home Goalie:	Auto / Manual
Injuries:	Adjust the frequency of injuries

SAVING / LOADING

The game automatically saves data for you after you exit a mode (Season, Tourney, Playoffs, etc), if you have a VMU with enough room that is! (126 Blocks)

TREYARCH

Executive Producer

Dr. Peter Akemann

Producer

Christopher A. Busse

Assistant Producers

John Andrunas

Lisa Ikeda

Susan Long

Lead Programmer

Charles Tolman

Programmers

Zachary Aeria

Thad Bowed

Marc Carlson

Mike Caruso

Amrit Dharwadkar

Paul Allen Edelstein

Tim Ford

John Lydon

Eric Hurd

Michael Mailhot

Jason L. McKesson

Mark Nau

Tim Probst

Adam R. Rakunas

Matthew Rusch

Programmers cont.

Dimiter "malkia" Stanev

John Stanley

Additional Programming

Chris Baker

Art Director

Christian Basic

Artists

Loudvik Akopyan

Jennifer Anderson

Scott Bendis

Darwin Dumlao

Sukru Gilman

Bradley P. Grace

Cameron S. Petty

Dan Santat

Erik M. Stone

Paul Whitehead

Johnny P. van Zelm

Additional Art

Casey McGonagle

Casto Vocal

Lead Animator

Dan B. Golden

Animators

Stephen Fedasz IV

Jay Juneau

CREDITS

Audio Director

Sergio Bustamante II

Music

Douglas Rappaport

Sound Designer

Kris Giampa

QA Lead

Sean Johnson

QA

Marc Droudian

Tech Support

Rose Villasenor

Additional Music

David Logan

Music Licensing Consultant

Maissa Dauriac

Play By Play

Bob Miller

Color Commentary

Mike Villani

Arena PA Announcer

Charles "Chuck" Klausmeyer

VO Recorded

Woodholly Studios

Woodholly Engineer

Steve Nafshun

Special Thanks

Doris Argoud

Shawn Capistrano

Don Likeness

Terri McAlpine

Kevin Tomatani

VISUAL CONCEPTS

Senior Producer

Greg Thomas

Project Manager

Randy Hauser

Director of Quality Assurance

Chien Yu

Lead Tester

Damon Perdue

Testers

Ben Doan

Kerry Glen

Shane Fenton

Chris Baker

Haven Rocha

Benjamin Bishop

Donell Williams

CREDITS

Testers Cont

Erik Andreassen
Erik Lampi
Junior Sison
Buddy Moles

Motion Capture Talent

Jason Cippola
Mike Bales
Joe Murphy

Special Thanks

Scott Patterson
Jane Thompson
Christian Lalonde
Abe Navarro
Linda Santiago
Black Box Games

SEGA OF AMERICA

Sr. Product Manager

Stacey Kerr

Associate Product Manager

Michael Rhinehart

Lead Tester

Ben Wisyanski

Assistant Lead Testers

Lee Frohman
Seth Benton

Testers

Jason Mercer
Seth Benson

Licensing

Robert Leffler

Creative Services

Bob Schonfisch – Director
Vicki Morawietz – Manual Designer
Allison Levenson – Production Artist

Manual

Keith M. Kolmos

Special Thanks

Peter Moore
Chris Gilbert
Cindy Jenney
John Diamonon
Dave Mc Carthy – NHL Enterprises
Linda Santiago – NHL Enterprises
Catherine O'Brien – NHL Enterprises
Ted Saskin – NHLPA
Mike Ouellet – NHLPA
Martin McQuaig – NHLPA
Richard Scott – NHLPA

NOTES

All trademarks are the property of their respective owners.

The names and logos of all arenas are trademarks of their respective owners and are used by permission.

Certain trademarks used herein [or hereon] are properties of American Airlines, Inc. used under license to Sega. All rights reserved.

NOTES

***THIS LIMITED WARRANTY IS VALID FOR U.S. AND CANADIAN SEGA DREAMCAST SOFTWARE MANUFACTURED FOR SALE IN AND PURCHASED AND OPERATED IN THE UNITED STATES AND CANADA, ONLY!**

Limited Warranty

Sega of America, Inc. warrants to the original consumer purchaser that the Sega Dreamcast GD-ROM shall be free from defects in material and workmanship for a period of 90-days from the date of purchase. If a defect covered by this limited warranty occurs during this 90-day warranty period, the defective GD-ROM or component will be replaced free of charge. This limited warranty does not apply if the defects have been caused by negligence, accident, unreasonable use, modification, tampering or any other causes not related to defective materials or workmanship. Please retain the original or a photocopy of your dated sales receipt to establish the date of purchase for in-warranty replacement. For replacement, return the disc, with its original packaging and receipt, to the retailer from which the software was originally purchased. In the event that you cannot obtain a replacement from the retailer, please contact Sega to obtain support.

Obtaining technical support/service

To receive additional support, including troubleshooting assistance, please contact Sega at

- web site (http://www.sega.com/customer_service)
- e-mail (support@sega.com)
- 800 number (1-800-USA-SEGA)
- Instructions en français, téléphoner au (1-800-872-7342).

LIMITATIONS ON WARRANTY

ANY APPLICABLE IMPLIED WARRANTIES, INCLUDING WARRANTIES OF MERCHANTABILITY AND FITNESS FOR A PARTICULAR PURPOSE, ARE HEREBY LIMITED TO 90-DAYS FROM THE DATE OF PURCHASE AND ARE SUBJECT TO THE CONDITIONS SET FORTH HEREIN. IN NO EVENT SHALL SEGA OF AMERICA, INC., BE LIABLE FOR CONSEQUENTIAL OR INCIDENTAL DAMAGES RESULTING FROM THE BREACH OF ANY EXPRESS OR IMPLIED WARRANTIES. THE PROVISIONS OF THIS LIMITED WARRANTY ARE VALID IN THE UNITED STATES ONLY. SOME STATES DO NOT ALLOW LIMITATIONS ON HOW LONG AN IMPLIED WARRANTY LASTS, OR EXCLUSION OF CONSEQUENTIAL OR INCIDENTAL DAMAGES, SO THE ABOVE LIMITATION OR EXCLUSION MAY NOT APPLY TO YOU. THIS WARRANTY PROVIDES YOU WITH SPECIFIC LEGAL RIGHTS. YOU MAY HAVE OTHER RIGHTS WHICH VARY FROM STATE TO STATE.

ESRB RATING

This product has been rated by the Entertainment Software Rating Board. For information about the ESRB rating, or to comment about the appropriateness of the rating, please contact the ESRB at 1-800-771-3772.

Sega is registered in the US Patent and Trademark Office. Sega, Dreamcast, the Dreamcast logo, and Sega Sports are either registered trademarks or trademarks of Sega Corporation. © SEGA CORPORATION, 2002. All Rights Reserved. www.sega.com. NHL, National Hockey League, the NHL Shield and the Stanley Cup are registered trademarks of the National Hockey League. All NHL logos and marks and team logos and marks depicted herein are the property of the NHL and the respective teams and may not be reproduced without the prior written consent of NHL Enterprises, L.P. © 2002 NHL. All rights reserved. Officially Licensed Product of the National Hockey League. Officially Licensed Product of the NHLPA. NHLPA, National Hockey League Players' Association and the NHLPA logo are trademarks of the NHLPA and are used under license by Sega. © NHLPA. Made and printed in the USA. WARNING: Operates only with NTSC televisions and Sega Dreamcast systems purchased in North and South America (except Argentina, Paraguay and Uruguay). Will not operate with any other televisions or Sega Dreamcast systems. Product covered under one or more of the following U.S. Patents: 5,460,374; 5,627,895; 5,688,173; 4,442,486; 4,454,594; 4,462,076; 6,102,800; Re. 35,839; Japanese Patent No.2870538, (Patents pending in U.S. and other countries); Canada Patent No. 1,183,276. The ratings icon is a trademark of the Interactive Digital Software Association. Sega of America Dreamcast, Inc, P.O. Box 7639, San Francisco, CA 94120.

"GET READY FOR THIS (INSTRUMENTAL)"

Words and Music by JEAN PAUL DE COSTER, FILIP DE WILDE & SIMON HARRIS © UNIVERSAL-MCA MUSIC LIMITED/LEOSONG COPYRIGHT SERVICE LIMITED, ALL RIGHTS OWNED OR ADMINISTERED IN THE UNITED STATES AND CANADA BY SONGS OF UNIVERSAL, INC/BMI

"ROCK AND ROLL PART 2"

Words and Music by GARY GLITTER & MIKE LEANDER © 1972 UNIVERSAL/MCA MUSIC LIMITED, ALL RIGHTS OWNED OR ADMINISTERED BY SONGS OF UNIVERSAL, INC/BMI

AVAILABLE NOW!

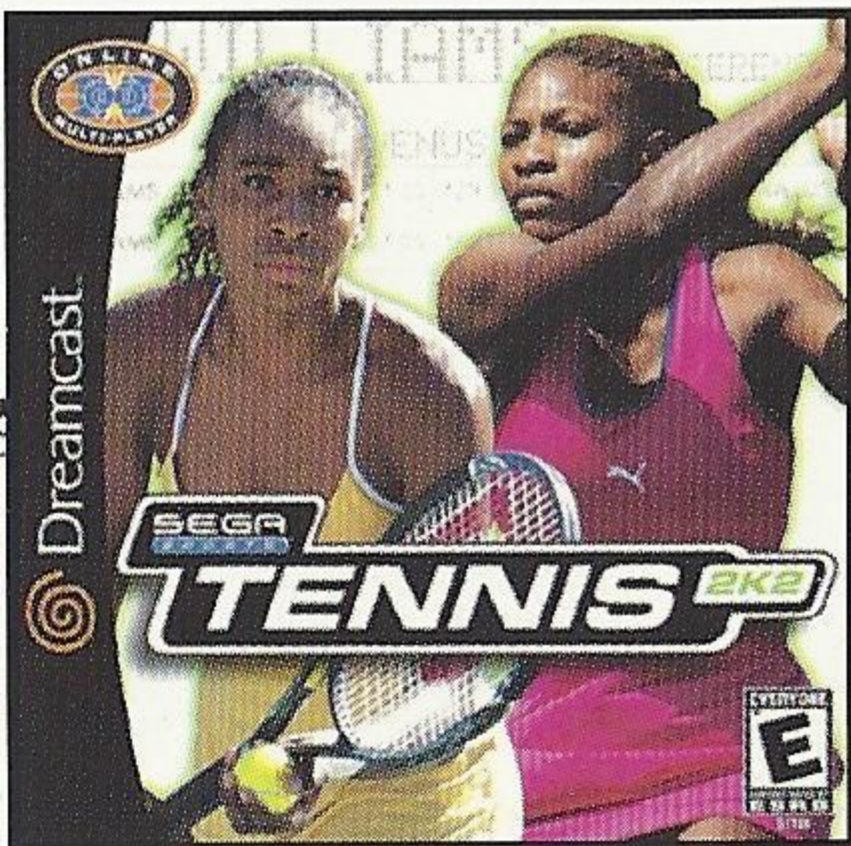

SEGA SPORTS TENNIS 2K2

SEGA
SPORTS™

Sega is registered in the U.S. Patent and Trademark Office. Sega, Dreamcast, the Dreamcast logo, and Sega Sports are either registered trademarks or trademarks of Sega Corporation © SEGA CORPORATION, 2002. All Rights Reserved. www.sega.com

