

2nd PRINTING
JUNE 2015

SEGA[®]

Sega Amusements Europe Limited.
42 Barwell Business Park, Leatherhead Road, Chessington, Surrey, KT9 2NY, United Kingdom.
Telephone: +44 (0) 208 391 8090 Facsimile: +44 (0) 208 391 8099
email: mailbox@sega.co.uk Web: <http://www.segaarcade.com>

Sega Corporation
Canal Side Bldg 1-39-9 Higashishinagawa Shinagawa-ku, Tokyo, 140-8583, Japan.
Telephone: +81-3-687-7133 Facsimile: +81-3-687-7134

© SEGA

SHOWDOWN SUPER DELUXE

OWNER'S MANUAL

420-0023-01K

SEGA[®]

OWNER'S MANUAL



IMPORTANT

- Before using this product, read this manual carefully to understand the contents herein stated.
- After reading this manual, be sure to keep it near the product or in a convenient place for easy reference when necessary.

BEFORE USING THE PRODUCT, BE SURE TO READ THE FOLLOWING:

To maintain safety:

To ensure the safe operation of this product, be sure to read the following before usage.

The following instructions are intended for the users, operators and the personnel in charge of the operation of the product. After carefully reading and sufficiently understanding the warning displays and cautions, handle the product appropriately. Be sure to keep this manual close to the product or in a convenient place for future reference.

Herein, explanations which require special attention are enclosed with dual lines. Depending on the potentially hazardous degrees, the terms of DANGER, WARNING, CAUTION, etc. are used. Be sure to understand the contents of the displays before reading the text.

 **DANGER** Indicates that mishandling the product by disregarding this pictograph will cause severe injury or death.

 **WARNING** Indicates that mishandling the product by disregarding this warning will cause a potentially hazardous situation which can result in death or serious injury.

 **CAUTION** Indicates that mishandling the product by disregarding this caution will cause a slight hazardous situation which can result in personal injury and/or material damage.

For the safe usage of the product, the following pictographs are used:

 Indicates "HANDLE WITH CARE." In order to protect the human body and equipment, this display is attached to places where the Owner's Manual, Serviceman Manual and/or Service Manual should be referred to.

- **Perform work in accordance with the instructions herein stated.** Instructions for work are explained by paying attention to the aspect of accident prevention. Failing to perform work as per the instructions can cause accidents. In the case where only those who have technical expertise should perform the work to avoid hazardous situation, the instructions herein state that the site maintenance personnel should perform such work.
- **Be sure to turn off the power before working on the machine.** To prevent an electric shock, be sure to turn off the power before carrying out any work that requires direct contact with the interior of the product. If the work is to be performed in the power-on status, the Instruction Manual herein always states to that effect.
- **Be sure to ground the Earth Terminal.** (This is not required in the case where a power cord with earth is used.)
- **This product is equipped with the Earth Terminal.** When installing the product, connect the Earth Terminal to the "accurately grounded indoor earth terminal" by using an earth wire. Unless the product is grounded appropriately, the user can be subject to an electric shock. After performing repair, etc. for the control equipment, ensure that the Earth Wire is firmly connected to the control equipment.
- **Ensure that the Power Supply used is equipped with an Earth Leakage Breaker.** This product does not incorporate the Earth Leakage Breaker. Using a power supply which is not equipped with the Earth Leakage Breaker can cause a fire when earth leakage occurs.
- **Be sure to use fuses which meet the specified rating.** (Only for the machines which use fuses.) Using fuses exceeding the specified rating can cause a fire and an electric shock. (Only for the machines which use fuses.) Using fuses exceeding the specified rating can cause a fire and an electric shock.

- **Specification changes (removal of equipment, conversion and addition) not designated by SEGA are not allowed.** The parts of the product include warning labels for safety, covers for personal protection, etc. It is very hazardous to operate the product by removing parts and/or modifying the circuits. Should doors, lids and protective parts be damaged or lost, refrain from operating the product, and contact where the product was purchased from or the office herein stated. SEGA shall not be held responsible for any accidents, compensation for damage to a third party, resulting from the specifications not designated by SEGA.
- Ensure that the product meets the requirements of appropriate electrical specifications. Before installing the product, check for electrical specifications. SEGA products have a nameplate on which electrical specifications are described. Ensure that the product is compatible with the power supply voltage and frequency requirements of the location. Using any electrical specifications different from the designated specifications can cause a fire and an electric shock.
- Install and operate the product in places where appropriate lighting is available, allowing warning labels to be clearly read. To ensure safety for the customers, labels and printed instructions describing potentially hazardous situations are applied to places where accidents can be caused. Ensure that where the product is operated has sufficient lighting allowing the warnings to be read. If any label is peeled off, apply it again immediately. Please place an order with where the product was purchased from or the office herein stated.
- When handling the monitor, be very careful. (Applies only to products with monitors.) Some of the monitor parts are subject to high tension voltage. Even after turning off the power, some portions are still subject to high tension voltage sometimes. Monitor repair and replacement should be performed only by those technical personnel who have knowledge of electricity and technical expertise.
- Be sure to adjust the monitor properly. (Applies only to products with monitors.) Do not operate the product leaving on-screen flickering or blurring as it is. Using the product with the monitor not properly adjusted may cause dizziness or a headache to an operator, a player, or the customers.
- When transporting or reselling this product, be sure to attach this manual to the product.
- *In the case where commercially available monitors and printers are used in this product, only the contents relating to this product are explained herein. Some commercially available equipment has functions and reactions not stated in this manual. Read this manual together with the specific instruction manual of such equipment.*
- *Descriptions herein contained may be subject to improvement changes without notice.*
- *The contents described herein are fully prepared with due care. However, should any question arise or errors be found, please contact SEGA.*

INSPECTIONS IMMEDIATELY AFTER TRANSPORTING THE PRODUCT TO THE LOCATION

Normally, at the time of shipment, SEGA products are in a status allowing for usage immediately after transporting to the location. Nevertheless, an irregular situation may occur during transportation. Before turning on the power, check the following points to ensure that the product has been transported in a satisfactory status.

- Are there any dented portions or defects (cuts, etc.) on the external surfaces of the cabinet?
- Are casters and adjusters damaged?
- Do the power supply voltage and frequency requirements meet with those of the location?
- Are all wiring connectors correctly and securely connected? Unless connected in the correct way, connector connections can not be made accurately. Do not insert connectors forcibly.
- Do power cables have cuts and dents?
- Are all accessories available?
- Can all doors and lids be opened with the accessory keys? Can doors and lids be firmly closed?

TABLE OF CONTENTS

| | | |
|----------|------------------------------------------------------|-----------|
| | INTRODUCTION | vi |
| 1 | HANDLING PRECAUTIONS | 1 |
| 2 | PRECAUTIONS REGARDING INSTALLATION LOCATION | 5 |
| | 2-1 LIMITATIONS OF USAGE | 6 |
| | 2-2 OPERATION AREA | 7 |
| | 2-3 OVERALL DIMENSIONS | 8 |
| 3 | PRECAUTIONS REGARDING PRODUCT OPERATION | 9 |
| | 3-1 BEFORE OPERATION | 9 |
| | 3-2 DURING OPERATION (PAYING ATTENTION TO CUSTOMERS) | 14 |
| 4 | PARTS DESCRIPTION | 19 |
| 5 | ACCESSORIES | 20 |
| 6 | ASSEMBLY AND INSTALLATION | 22 |
| | 6-1 UNPACKING THE CABINET | 25 |
| | 6-2 ATTACHING THE SIDE LED TO THE MONITOR | 27 |
| | 6-3 POSITIONING & INSTALLING THE CABINETS | 29 |
| | 6-4 FITTING THE MARQUEE BLOCKS | 33 |
| | 6-5 FITTING THE BILBOARD PLATE | 37 |
| | 6-6 CONNECTING THE MARQUEE | 39 |
| | 6-7 FITTING THE 42" DISPLAYS | 41 |
| | 6-8 CONNECTING THE CAMERAS | 46 |
| | 6-9 LINKING THE CABINETS (COMMUNICATION) | 48 |
| | 6-10 APPLYING COVERS | 49 |
| | 6-11 APPLYING POWER | 50 |
| | 6-12 CONFIRMATION OF INSTALLATION | 55 |
| 7 | PRECAUTIONS WHEN MOVING | 57 |
| | 7-1 MOVING THE MACHINE | 58 |
| 8 | GAME DESCRIPTION | 60 |
| 9 | EXPLANATION OF TEST AND DATA DISPLAY | 69 |
| | 9-1 SWITCH UNIT AND COIN METER | 70 |
| | 9-2 TEST MODE | 71 |
| | 9-3 MOTION SAFETY SYSTEM | 91 |
| | 9-4 TROUBLESHOOTING | 94 |
| | 9-5 ERROR MESSAGES | 96 |

| | | |
|-----------|-----------------------------------------------|------------|
| 10 | VIDEO DISPLAY | 98 |
| | 10-1 GENERAL DESCRIPTION | 98 |
| | 10-2 CLEANING THE SCREEN | 99 |
| 11 | CONTROL UNITS | 100 |
| | 11-1 CONTROLLER - EXPLODED DIAGRAM | 102 |
| | 11-2 BRAKE AND ACCELERATOR UNIT | 103 |
| | 11-3 ADJUSTING/REPLACING THE VOLUME POT | 105 |
| | 11-4 GREASING | 107 |
| | 11-5 MOTION BASE AND SEAT | 108 |
| 12 | COIN HANDLING | 113 |
| | 12-1 CLEANING THE COIN SELECTOR | 113 |
| | 12-2 FAULT FINDING | 116 |
| | 12-3 ADJUSTING THE PRICE OF PLAY (EXCEL) | 117 |
| | 12-4 ADJUSTING THE PRICE COMMON (USA) | 118 |
| 13 | REPLACING INCANDESCENT LAMPS | 123 |
| | 13-1 COIN DOOR LAMP | 123 |
| | 13-2 MOTION STOP LAMP | 124 |
| 14 | PERIODIC INSPECTION | 126 |
| | 14-1 CLEANING SENSORS AND GREASING SEAT RAILS | 128 |
| | 14-2 CLEANING SENSORS AND GREASING SEAT RAILS | 128 |
| 15 | TROUBLESHOOTING & ERROR CODES | 129 |
| 16 | GAME BOARD | 131 |
| | 16-1 HOW TO REMOVE GAME BOARD | 132 |
| 17 | DESIGN RELATED PARTS | 133 |
| 18 | PARTS LIST | 134 |
| 19 | WIRE COLOUR CODE TABLE | 194 |
| 20 | SCHEMATIC DIAGRAMS (1 OF4) | 195 |
| | (2 of 4) | 196 |
| | (3 of 4) | 197 |
| | (4 of 4) | 198 |

INTRODUCTION

This manual is intended to provide detailed descriptions together with all necessary information covering the general operation of electronic assemblies, electromechanical, servicing control, spare parts, etc. for the product, "SHOWDOWN SUPER DELUXE"

This manual is intended for the owners, personnel managers in charge of operation of this product. Operate the product after carefully reading and sufficiently understanding the instructions.

In the unlikely event that the product does not function correctly, DO NOT allow anyone other than a technician to touch the internal system. Turn off the power to the machine, making sure to unplug the electrical cord from the outlet, and contact the office listed below or the point-of-purchase for this product.

Use of this product is unlikely to cause physical injuries or damage to property. However, points that require special attention are indicated by bold text, the words "STOP, IMPORTANT or CAUTION" and the symbols below.

IMPORTANT

Indicates important information that, if ignored, may result in the mishandling of the product and cause faulty operation or damage to the product.

WARNING **CAUTION**

Indicates a warning or caution that, if ignored, may result in the mishandling of the product and cause faulty operation or damage to the product.

Sega Amusements Europe Limited.

42 Barwell Business Park, Leatherhead Road, Chessington, Surrey, KT9 2NY. United Kingdom.

European Sales: +44 (0) 208 391 8090 Facsimile: +44 (0) 208 391 8099

STS (Spares): +44 (0) 208 391 8060 Facsimile: +44 (0) 208 391 8096

email: mailbox@sega.co.uk Web: <http://www.segaarcade.com>

Sega Corporation

Canal Side Bldg 1-39-9 Higashishinagawa Shinagawa-ku, Tokyo, 140-8583, Japan.

Telephone: +81-3-687-7133 Facsimile: +81-3-687-7134

Play It! Amusements, inc.

252 Beinoris Drive, Wood Dale, IL. 60191, USA

USA Sales: +00 (1) 224 265 4287

SPECIFICATIONS

Installed Dimensions & Specifications

Machine Dimensions: 8.7m (342.5in.) [Width] x 2.23m (87.7in.) [Depth]

Machine Height: 2.83m (111.5in.) (Inc Marquee))

Machine Weight: 496kg (1093.49lb) Approx

Installed Rating: @AC238V - 20A Max - 50/60Hz

@AC120V - 38A Max - 50/60Hz

WARNING

Servicing and maintenance work of the contents herein stated should be performed by the SERVICEMAN stipulated as per IEC Standard. Those who do not have technical expertise and knowledge other than the SERVICEMAN are not allowed to perform the work herein stated. Executing aforementioned work by such non-technical personnel can cause serious accidents that may endanger life.

Parts replacement, maintenance inspections and troubleshooting should be carried out by site maintenance personnel or other qualified professionals. This manual includes directions for potentially dangerous procedures which should only be carried out by professionals with the appropriate specialised knowledge.

The site maintenance personnel or other qualified professionals mentioned in this manual are defined as follows:

Site maintenance personnel:

Individuals with experience in maintaining amusement equipment, vending machines, etc., working under the supervision of the owner/operator of this product to maintain machines within amusement facilities or similar premises by carrying out everyday procedures such as assembly, maintenance inspections, and replacement of units/expendable parts.

Activities to be carried out by site maintenance personnel:

Amusement equipment/vending machine assembly, maintenance inspection and replacement of units/expendable parts.

Other qualified professionals:

Persons employed by amusement equipment manufacturers, or involved in design, production, testing or maintenance of amusement equipment. The individual should have either graduated from technical school or hold similar qualifications in electrical/electronics/mechanical engineering.

Activities to be carried out by other qualified professionals:

Amusement equipment/vending machine assembly, repair/adjustment of electrical/electronic/mechanical parts.

Waste of Electrical and Electronic Equipment (WEEE) Statement.

The WEEE (Waste of Electrical and Electronic Equipment) directive places an obligation on all EU based manufacturers and importers of Electrical and Electronic Equipment to take back products at the end of their useful life. Sega Amusements Europe Ltd accepts its responsibility to finance the cost of treatment and recovery of redundant WEEE in the United Kingdom in accordance with the specified WEEE recycling requirements.

The symbol shown below will be on all products manufactured from 13th August 2005, which indicates this product must NOT be disposed of with other normal waste. Instead, it is the user's responsibility to dispose of their waste equipment by arranging to return it to a designated UK collection point for the correct recycling of waste electrical and electronic equipment.

For more information about where you can send your waste equipment for recycling contact your local authority office.

For non-UK users contact your local authority office for information on the recycling of Waste Electrical and Electronic Equipment.

Battery Recycling Statement.

The EC Directive on Batteries and Accumulators (2006/66/EC) aims to minimise the impact of batteries on the environment and encourage the recovery of the materials they contain. To achieve increased collection and recycling of waste batteries, the Directive places 'producer responsibility' obligations on manufacturers and importers of portable, industrial and automotive batteries.

The symbol shown below will be on all equipment fitted with batteries from 26th September 2008 and indicates they must NOT be disposed of with other normal waste. Instead, it is the user's responsibility to dispose of used batteries by arranging to return them to a designated collection point for the correct recycling.

For more information about where you can send your waste batteries for recycling contact your local authority office.

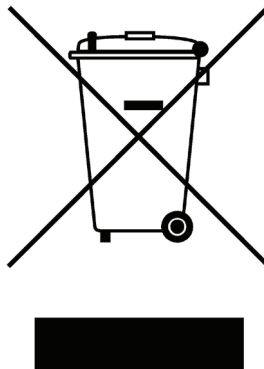

REGISTERED IN ENGLAND REGISTERED NO. 1711515

REGISTERED OFFICE: BLOCK C 42 BARWELL BUSINESS PARK, CHESSINGTON, SURREY KT9 2NY

1 HANDLING PRECAUTIONS

When installing or inspecting the machine, be very careful of the following points and pay attention to ensure that the player can enjoy the game safely.

Non-compliance with the following points or inappropriate handling running counter to the cautionary matters herein stated can cause personal injury or damage to the machine.

WARNING

- Before performing work, be sure to turn the power off. Performing the work without turning the power off can cause an electric shock or short circuit. In the case work should be performed in the status of power on, this manual always states to that effect.
- To avoid an electric shock or short circuit, do not plug in or unplug quickly.
- To avoid an electric shock, do not plug in or unplug with a wet hand.
- Do not expose power cords or earth wires on the surface, (floor, passage, etc.). If exposed, the power cords and earth wires are susceptible to damage. Damaged cords and wires can cause an electric shock or short circuit.
- To avoid causing a fire or an electric shock, do not put things on or damage the power cords.
- When or after installing the product, do not unnecessarily pull the power cord. If damaged, the power cord can cause a fire or an electric shock.
- In case the power cord is damaged, ask for a replacement through where the product was purchased from or the office herein stated. Using the cord as is damaged can cause fire, an electric shock or leakage.
- Be sure to perform grounding appropriately. Inappropriate grounding can cause an electric shock.
- Be sure to use fuses meeting the specified rating. Using fuses exceeding the specified rating can cause a fire or an electric shock.
- Be sure that connections such as IC BD are made properly. Insufficient insertion can cause an electric shock.
- Specification changes, removal of equipment, conversion and/or addition, not designated by SEGA are not permitted.
 - Failure to observe this may cause a fire or an electric shock. Non-compliance with this instruction can have a bad influence upon physical conditions of the players or the onlookers, or result in injury during play.
 - SEGA shall not be held responsible for damage, compensation for damage to a third party, caused by specification changes not designated by SEGA.
- Do not perform any work or change parts not listed in this manual. Doing so may lead to an accident.

If you need to perform any work not listed in this manual, request work from the office indicated in this manual or the point of purchase, or inquires for details.
- Be sure to perform periodic maintenance inspections herein stated.

STOP IMPORTANT

- For the IC board circuit inspections, only the logic tester is allowed. The use of a multiple-purpose tester is not permitted, so be careful in this regard.
- The LED VProjector and screen are employed for this machine. The screen is susceptible to damage, therefore, be very careful when cleaning the screen. For details, refer to the section “Projector.”
- Static electricity from your body may damage some electronics devices on the IC board. Before handling the IC board, touch a grounded metallic surface so that the static electricity can be discharged.
- Some parts are not designed and manufactured specifically for this game machine. The manufacturers may discontinue, or change the specifications of such general-purpose parts. If this is the case, SEGA cannot repair or replace a failed game machine whether or not a warranty period has expired.

CONCERNING THE STICKER DISPLAY

This SEGA product has stickers attached describing the product manufacture No. (Serial No.) and Electrical Specifications. It also has a Sticker describing where to contact for repair and for purchasing parts.

When inquiring about or asking for repairs, mention the Serial No. and Name of Machine indicated on the Sticker. The Serial Number indicates the product register. Identical machines could have different parts depending on the date of production. Also, improvements and modifications might have been made after the publication of this manual. In order to ensure you order the correct parts, mention the Serial No. when contacting the applicable places.

CONCERNING WARNING DISPLAYS

This SEGA product has warning displays on stickers, labels and/or printed instructions adhered/attached to or incorporated in the places where a potentially hazardous situation could arise. The warning displays are intended for accident prevention for customers and for avoiding hazardous situations relating to maintenance and servicing work. Some portions of the cabinet contain high voltage and may cause accidents if touched. When performing maintenance, be very careful of the warning displays. It is especially important that any complex repair and replacement work not mentioned herein should be performed by those technical personnel who have knowledge of electricity and technical expertise. In order to prevent accidents, caution any customer ignoring the warnings to cease and desist immediately.

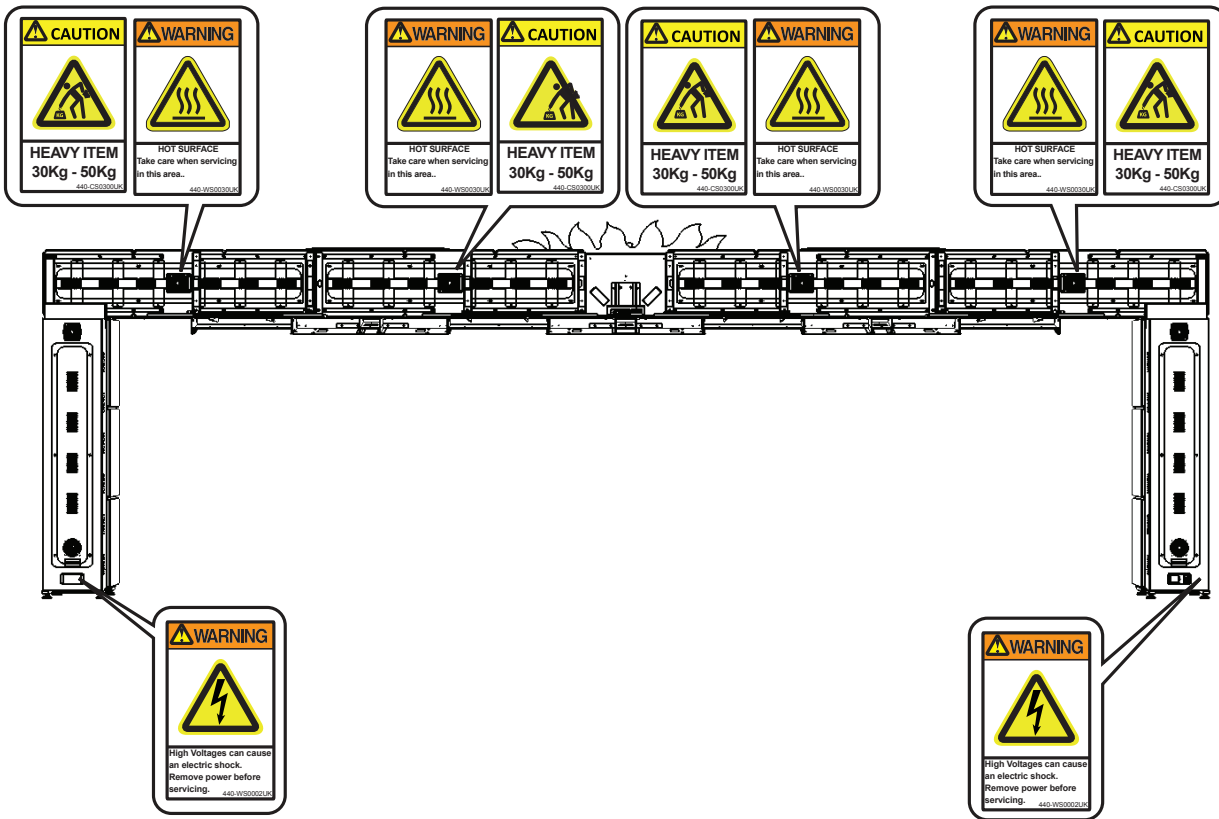

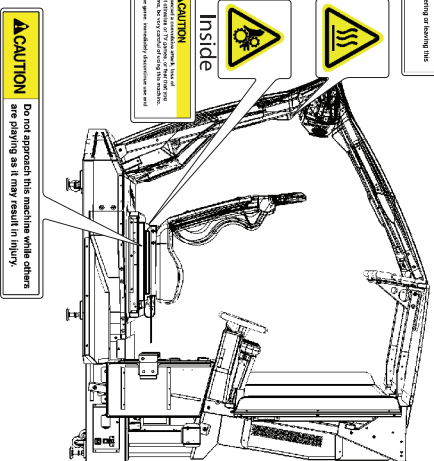
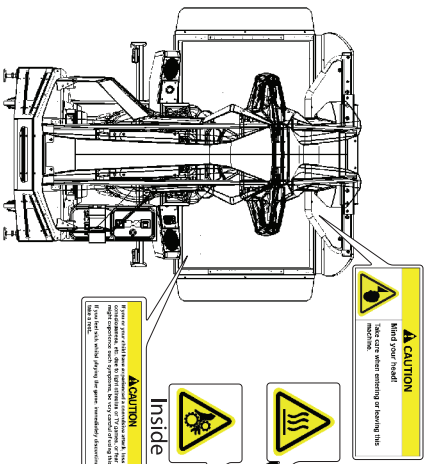
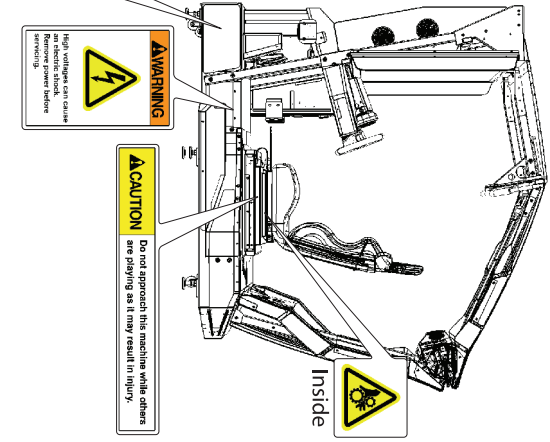
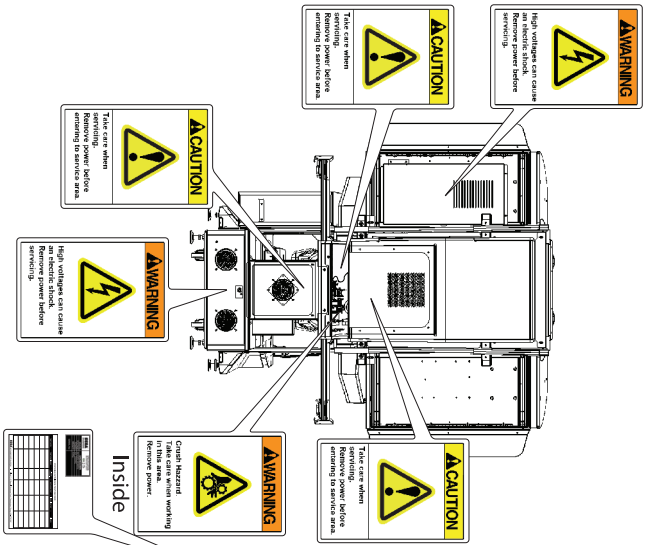
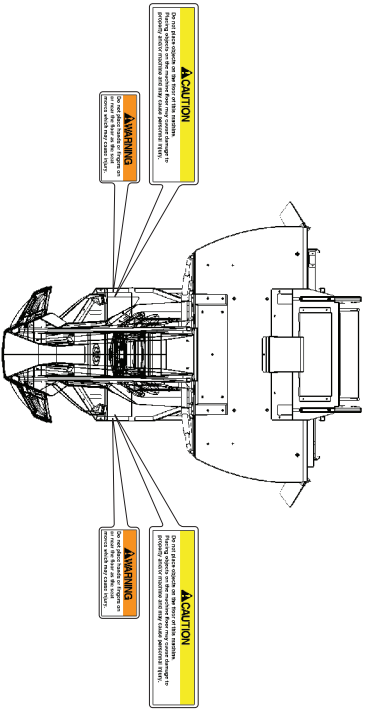

2 PRECAUTIONS REGARDING INSTALLATION LOCATION

2 PRECAUTIONS REGARDING INSTALLATION LOCATION

WARNING

This product is an indoor game machine. Do not install it outside. Even indoors, avoid installing in places mentioned below so as not to cause a fire, electric shock, injury and/or malfunction.

- Places subject to rain or water leakage, or places subject to high humidity in the proximity of an indoor swimming pool and/or shower, etc.
- Places subject to direct sunlight, or places subject to high temperatures in the proximity of heating units, etc.
- Places filled with inflammable gas or vicinity of highly inflammable/volatile chemicals or hazardous matter.
- Dusty places.
- Sloped surfaces.
- Places subject to any type of violent impact.
- Vicinity of anti-disaster facilities such as fire exits and fire extinguishers.
- The operating (ambient) temperature range is not from 5°C to 30°C.
- Places near water or spray from water such as a Jet Wash or Swimming Pool.

2-1 LIMITATIONS OF USAGE

WARNING

- Be sure to check the Electrical Specifications. Ensure that this product is compatible with the location's power supply, voltage, and frequency requirements. A plate describing Electrical Specifications is attached to the product. Non-compliance with the Electrical Specifications can cause a fire and electric shock.
- This product requires a breaker and earth mechanism as part of the location facilities. Using the product without these can cause a fire and electric shock.
- Ensure that the indoor wiring for the power supply is rated at 15 A or higher (AC single phase 100 V ~ 120 V area), and 7 A or higher (AC 220 V ~ 240 V area). Non-compliance with the Electrical Specifications can cause a fire and electric shock.
- Be sure that the ring main has a rating of 32A (AC220V ~ 240V area) and
- Be sure to use an independent power supply equipped with an earth leakage breaker. Using a power supply without an earth leakage breaker can cause an outbreak of fire if a power surge occurs.
- Putting many loads on one electrical outlet can cause generation of heat and a fire resulting from overload.
- When using an extension cord, ensure that the cord is rated at 15 A or higher (AC 100 V ~ 120 V area) and 7 A or higher (AC 220 V ~ 240 V area). Using a cord rated lower than the specified rating can cause a fire and electric shock.

Electricity Consumption:

Car 1 = 720w
Car 2 = 720w
Car 3 = 720w
Car 4 = 720w
2x 42" Displays = 720w
Overhead Gantry = 1.2KW

Total wattage. 4.8KW

2-2 OPERATION AREA

WARNING

- For the operation of this machine, secure a minimum area of 9.7 m (W) x 5m (D). If the machine rolls during play it could lead to serious injury, especially if anyone is hit on the head. You must secure the space specified in this document.
- Be sure to provide sufficient space specified in this manual. Do not allow objects to block the ventilation ports. It can cause generation of heat and a fire.
- SEGA shall not be held responsible for damage or compensation for damage to a third party, resulting from the failure to observe this instruction.
- If the machine does not fit through the entryway to the installation location, do not disassemble it without first consulting the instructions. If the machine still does not fit through the entryway after following the procedures in this manual, contact your retailer or the office listed in this manual.

IMPORTANT

Secure an area of no less than 9.7m x 5m for operation taking into consideration the safety of the players and on-lookers of this game.

To install this product, the entrance must be at least 1.52 m in width and 2.06 m in height.

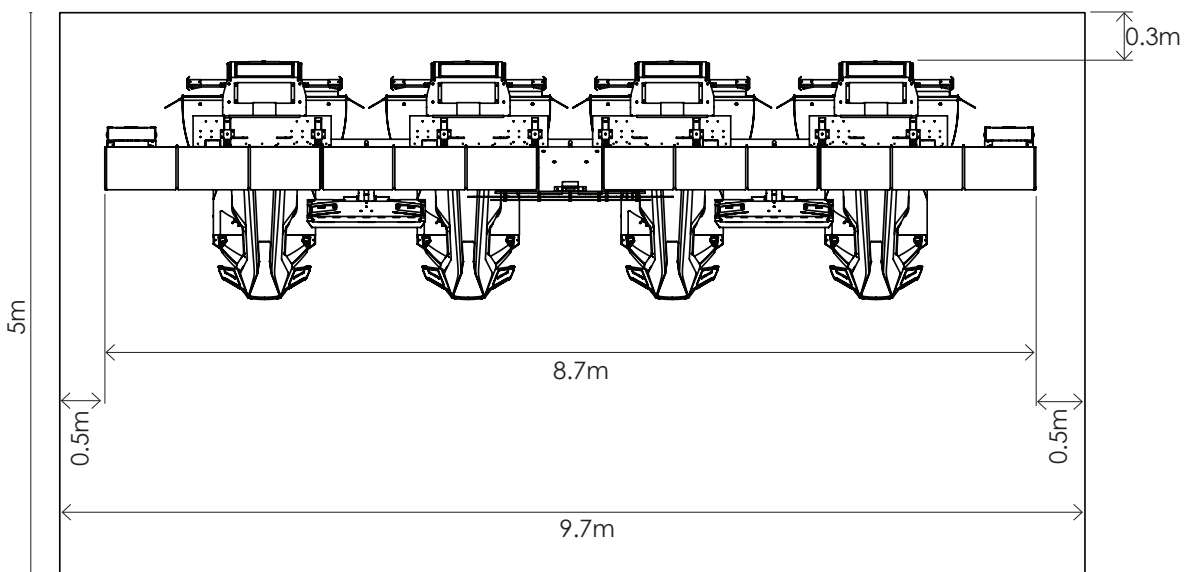

2-3 OVERALL DIMENSIONS

This page has been devised as a guide for installation and location

2 PRECAUTIONS REGARDING INSTALLATION LOCATION

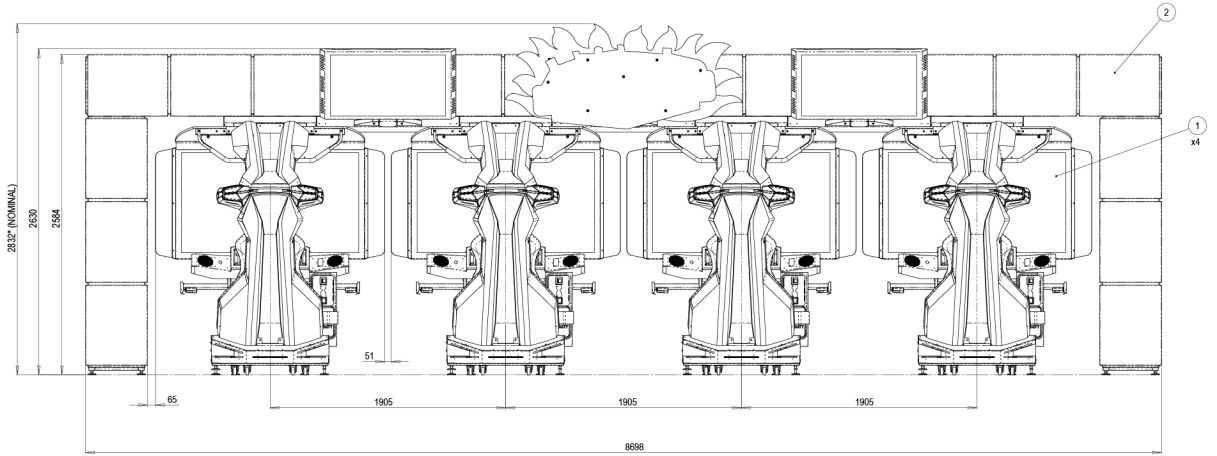

Not to scale

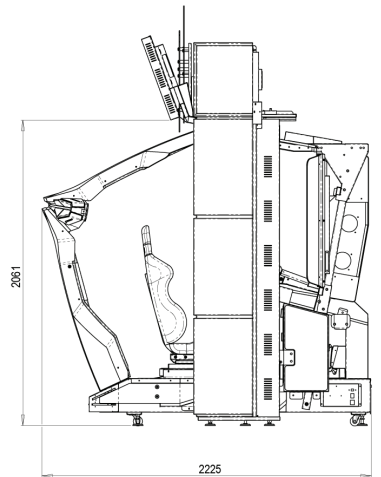

3 PRECAUTIONS REGARDING PRODUCT OPERATION

To avoid injury and trouble, be sure to pay attention to the behavior of visitors and players.

3-1 BEFORE OPERATION

WARNING

In order to avoid accidents, check the following before starting the operation:

- To ensure maximum safety for the players and the customers, ensure that where the product is operated has sufficient lighting to allow any warnings to be read. Operation under insufficient lighting can cause bodily contact with each other, hitting accident, and/or trouble between customers.
- Be sure to perform appropriate adjustment of the monitor (projector). For operation of this machine, do not leave monitor's flickering or deviation as is. Failure to observe this can have a bad influence upon the players' or the customers' physical conditions.
- It is suggested to ensure a space allowing the players who feel sick while playing the game to take a rest.
- Check if all of the adjusters are in contact with the surface. If they are not, the Cabinet can move and cause an accident.

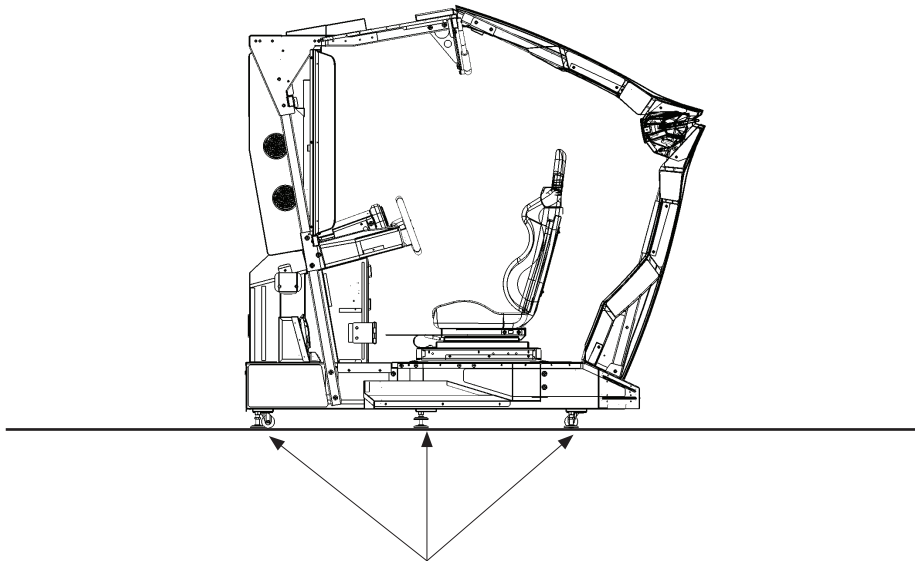

Ensure that all of the 6 adjusters are in contact with the floor.

 WARNING

- **Make sure the surrounding area is secure before turning the power on. The machine will automatically go through an initialization process after being turned on. The seat will move left and right, and persons standing in the vicinity of the machine may be struck or knocked down.**

- **Be sure to perform a test run of the machine and inspect its safety devices before putting it into operation. Because the machine's seat swerves to the left and right, it is equipped with safety devices. In order to ensure that these safety devices are functioning properly, it is imperative that the following checks be performed on a regular basis:**
 - **When the safety belt is released, does the seat stop moving?**
 - **Does the safety belt hold the player's body firmly in place?**
 - **Are there any damaged or frayed spots on the safety belt?**
 - **Are any of the seat parts loose or wobbly?**
 - **When the "Motion Stop" button is pressed, does the seat stop moving?**
 - **When the safety sensor detects a foreign object, does the seat stop moving?**
 - **Are the yellow-and-black-striped parts on the front and rear of the cockpit frame torn or missing?**

- **When performing the above safety checks, verify also that the seat is moving properly. Accidents may occur if the seat is moving abnormally. For this reason, do not operate the machine in such cases until the problem is resolved.**
 - **Does the seat move in the direction that the controls are pressed?**
 - **Does the seat move smoothly?**
 - **Does the seat shake or rattle?**
 - **Are any unusual sounds produced during seat motion?**
 - **Does the seat experience unusual vibration while moving?**
 - **When the game is over, does the seat come to rest in a level position?**

- **If the yellow-and-black-striped parts at the front and rear of the cockpit become damaged or fall off, replace them immediately. Hands and fingers may be broken and/or severed if inserted into these areas during gameplay.**

- **If the seat motion mechanism begins to malfunction, immediately cease operation, turn off the power, unplug the power cord, and contact the office listed in this manual or your retailer. Continuing to operate the machine without resolving the problem may result in serious accidents such as electric shock, short circuits, or fire, and/or cause the machine to tip over.**

- **Requests for maintenance of the seat motion mechanism should be directed to the office listed in this manual or your retailer. Attempts to perform maintenance by persons other than specially trained technicians may result in injury to the party performing the maintenance and/or to players during product operation.**

⚠ WARNING

- Do not put any heavy item on this product. Placing any heavy item on the product can cause a falling down accident or parts damage.
- Do not climb on the product. Climbing on the product can cause falling down accidents. To check the top portion of the product, use a step ladder.
- When using a stepladder or stool while working, do not hold onto the billboard carrier (the round pipe section). Holding or hanging off this may bend it out of shape or damage it, and could lead to a fall or an accident.
- To avoid electric shock, check to see if door & cover parts are damaged or omitted.
- To avoid electric shock, short circuit and/or parts damage, do not put the following items on or in the periphery of the product.

[Flower vases, flowerpots, cups, water tanks, cosmetics, and receptacles/containers/vessels containing chemicals and water.]

⚠ CAUTION

- To avoid injury, be sure to provide sufficient space by considering the crowd situation at the installation location. Insufficient installation space can cause customers to bump into each other, causing trouble.
- Every day when cleaning the Control (Steering Wheel), inspect the hoop and buttons and make sure that there are no scratches or cracks in the surface, and that the fastening screws are not loose. If the game is played with scratches, cracks or loose screws, it can cause injuries to the player or to people nearby.

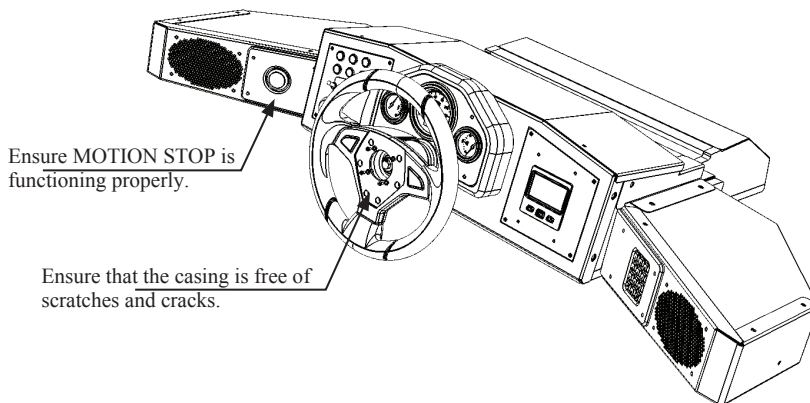

- When you clean the cabinet each day, always make sure that there is nothing placed on the seats and that they are not damp or wet. The construction of this product may allow for willful misconduct by players.

STOP IMPORTANT

To ensure customers enjoy playing the game, clean the Control Unit regularly. If there is any dirt buildup, the buttons may not return properly after being pressed.

DURING OPERATION (PATRON CONDUCT)

To avoid injury and unacceptable behavior, be sure to constantly give careful attention to the behavior and manner of the spectators and players alike..

⚠ WARNING

- To avoid injury and accidents, those who fall under the following categories are not allowed to play the game.
 - Those who need assistance such as the use of an apparatus when walking.
 - Those who have high blood pressure or a heart problem.
 - Those who have experienced muscle convulsion or loss of consciousness when playing video game, etc.
 - Those who have a trouble in the neck and or spinal cord.
 - Intoxicated persons.
 - Pregnant women or those who are in the likelihood of pregnancy.
 - Persons susceptible to motion sickness.
 - Persons whose act runs counter to the product's warning displays.
- A player who has never been adversely affected by light stimulus might experience dizziness or headache depending on his physical condition when playing the game.
- Instruct those who feel sick during play to have a medical examination.
- To avoid injury resulting from falling down and electric shock due to spilled drinks, instruct the player not to place heavy items or drinks on the product.
- To avoid electric shock and short circuit, do not allow patrons to put hands and fingers or extraneous matter in the openings of the product or small openings in or around the doors.
- To avoid injury resulting from falling down, immediately stop patron's leaning against or climbing on the product, etc.
- To avoid electric shock and short circuit, do not allow patrons to unplug the power plug without a justifiable reason.
- For safety reasons, this game must not be played by persons less than 140 cm in height. Patrons should be told that this is because the safety belt cannot secure such persons in place.

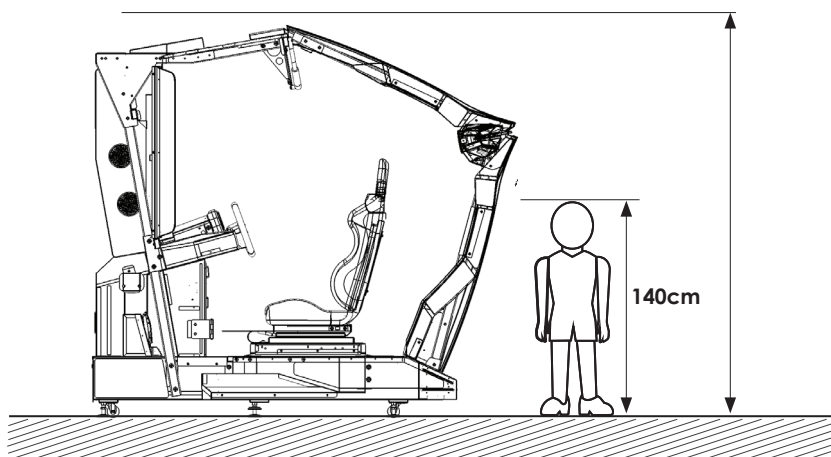

WARNING

- **Make sure the surrounding area is secure before turning the power on.**
The machine will automatically go through an initialization process after being turned on. The seat will move left and right, and persons standing in the vicinity of the machine may be struck or knocked down.
- **Be sure to perform a test run of the machine and inspect its safety devices before putting it into operation.** Because the machine's seat swerves to the left and right, it is equipped with safety devices. In order to ensure that these safety devices are functioning properly, it is imperative that the following checks be performed on a regular basis:
 - When the safety belt is released, does the seat stop moving?
 - Does the safety belt hold the player's body firmly in place?
 - Are there any damaged or frayed spots on the safety belt?
 - Are any of the seat parts loose or wobbly?
 - When the "Motion Stop" button is pressed, does the seat stop moving?
 - When the safety sensor detects a foreign object, does the seat stop moving?
 - Are the yellow-and-black-striped parts on the front and rear of the cockpit frame torn or missing?
- **When performing the above safety checks, verify also that the seat is moving properly.** Accidents may occur if the seat is moving abnormally. For this reason, do not operate the machine in such cases until the problem is resolved.
 - Does the seat move in the direction that the controls are pressed?
 - Does the seat move smoothly?
 - Does the seat shake or rattle?
 - Are any unusual sounds produced during seat motion?
 - Does the seat experience unusual vibration while moving?
 - When the game is over, does the seat come to rest in a level position?
- **If the yellow-and-black-striped parts at the front and rear of the cockpit become damaged or fall off, replace them immediately.** Hands and fingers may be broken and/or severed if inserted into these areas during gameplay.
- **If the seat motion mechanism begins to malfunction, immediately cease operation, turn off the power, unplug the power cord, and contact the office listed in this manual or your retailer.** Continuing to operate the machine without resolving the problem may result in serious accidents such as electric shock, short circuits, or fire, and/or cause the machine to tip over.
- **Requests for maintenance of the seat motion mechanism should be directed to the office listed in this manual or your retailer.** Attempts to perform maintenance by persons other than specially trained technicians may result in injury to the party performing the maintenance and/or to players during product operation.

3-2 DURING OPERATION (PAYING ATTENTION TO CUSTOMERS)

To avoid injury and trouble, be sure to pay attention to the behavior of visitors and players.

WARNING

- For safety reasons, do not allow any of the following people to play the game.
 - Those who require supporting devices, etc., to walk.
 - Those who have high blood pressure or a heart problem.
 - Those who have experienced muscle convulsion or loss of consciousness when playing video games, etc.
 - Those who have neck or spinal cord problems.
 - Intoxicated persons.
 - Pregnant women.
 - Persons susceptible to motion sickness.
 - Persons who disregard the product's warning displays.
- Even players who have never been adversely affected by light stimulus might experience dizziness or headache depending on their physical condition when playing the game. Small children are especially likely to experience these symptoms. Caution guardians of small children to keep watch on their children during play.
- Instruct those who feel sick during play to have a medical examination.
- To avoid injury from falls and electric shocks due to spilled drinks, instruct the player not to place heavy items or drinks on the product.
- To avoid electric shocks and short circuits, do not allow customers to put hands and fingers or extraneous matter in the openings of the product or small openings in or around the doors.
- To avoid falls and resulting injury, stop the customer from leaning against or climbing on the product, etc.
- To avoid electric shock and short circuit, do not allow customers to unplug the power plug without a justifiable reason.

CAUTION

- Immediately stop such violent acts as hitting and kicking the product. Such violent acts can cause parts damage or falling down, resulting in injury due to fragments and falling down.
- Two or more players must never be allowed to play using a single Control Unit. Playing in such a way could lead to physical injuries.
- When entering or exiting the machine, players may trip over the base. Be sure to warn players who do not appear to be exercising proper caution.

IMPORTANT

The interior of the cabinet is hard to see from the outside which may lead to willful misconduct by players or accidents going unnoticed. When the game is not in use, check the interior at regular intervals and make sure that nothing has been forgotten or placed on the seats.

⚠ WARNING

- **Playing the game without first securing the safety belt may cause players to fall out. Patrons should be instructed always to secure themselves with the safety belt before playing the game.**

(Seat Belt only available in some countries).

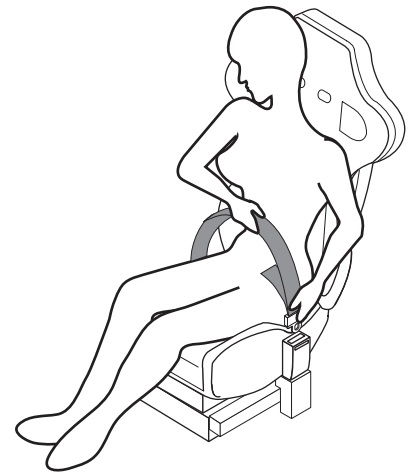

- **Prevent patrons from sitting two at a time in the seat. This game is for one player only. If two or more patrons attempt to sit in the seat and play at the same time, they may hit their heads, hands, or elbows, possibly resulting in serious injury.**



- **Patrons should not be allowed to climb onto the back of the seat. Such behavior may cause players to fall out and/or cause the machine to tip over. If a patron is riding on the back of the seat, have him or her get off immediately.**

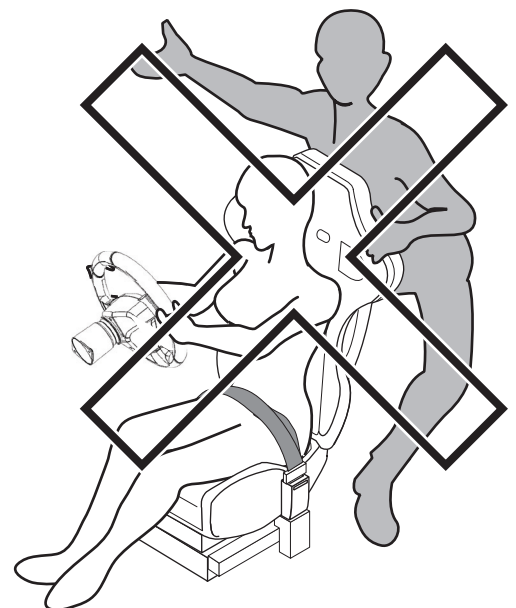

⚠ WARNING

Patrons should be warned not to place children on their laps while they play the game. Doing so may cause the child to become trapped between the player and the control panel and/or cause the machine to tip over.

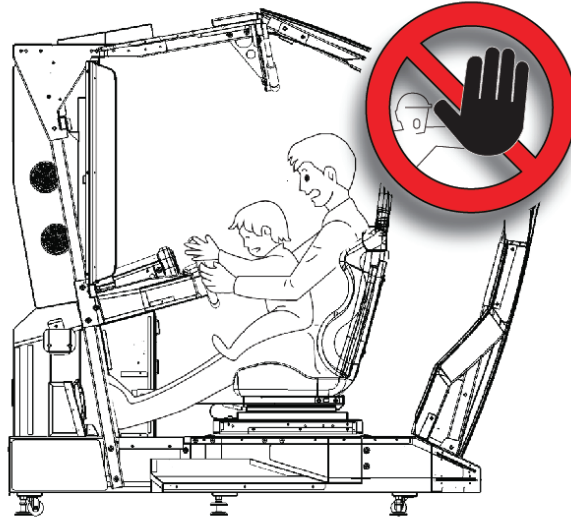

Persons other than the player should not be allowed to approach the machine while the seat is in motion. Such actions may result in sideswiping and/or collision accidents. The safety sensor is only able to detect foreign objects on top of the base. Young children are especially susceptible to this danger; for this reason, patrons should be instructed to watch their children closely.

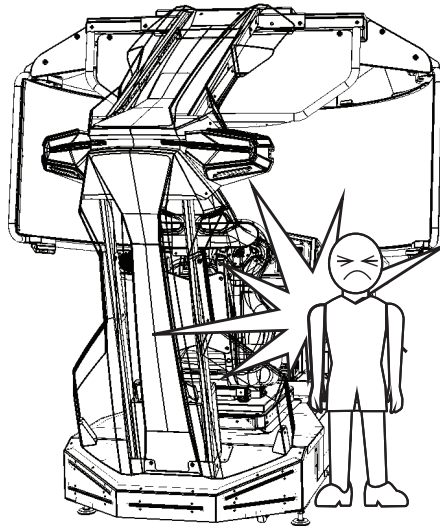

Patrons should be advised to place their feet upon the pedals during play. If patrons move their legs around without due attention, they may become trapped or snagged, possibly resulting in broken bones and/or sprains.

Prevent patrons from playing the game with bag straps or scarves wrapped round their necks or while holding on to drinks, as this can lead to accidents. If a player appears to be in distress, stop the seat motion immediately by pressing the “Motion Stop” button.

⚠ CAUTION

- Immediately stop such violent acts as hitting and kicking the product. Such violent acts can cause parts damage or falling down, resulting in injury due to fragments and falling down.
- When entering or exiting the machine, players may trip over the base or hit their heads on the pipes. Be sure to warn players who do not appear to be exercising proper caution.
- Players should be warned not to place personal effects or other objects on the base of the machine. If the safety sensor fails to detect these items, the motion of the machine may cause them to fly out and strike other patrons.

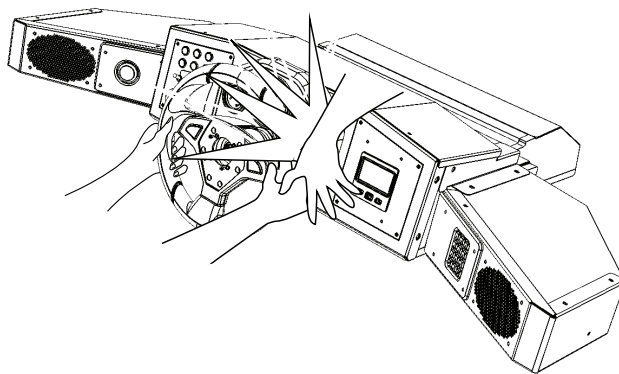

- Players should be instructed to adjust the seat by moving it forward or backward to fit their body size before playing the game. Playing the game in an unnatural position can lead to unforeseen accidents.
- Persons other than the player should not be allowed to touch the controls during play. They may brush against or collide with the controls or the player, possibly resulting in accidents.

4 PARTS DESCRIPTION

CABINET

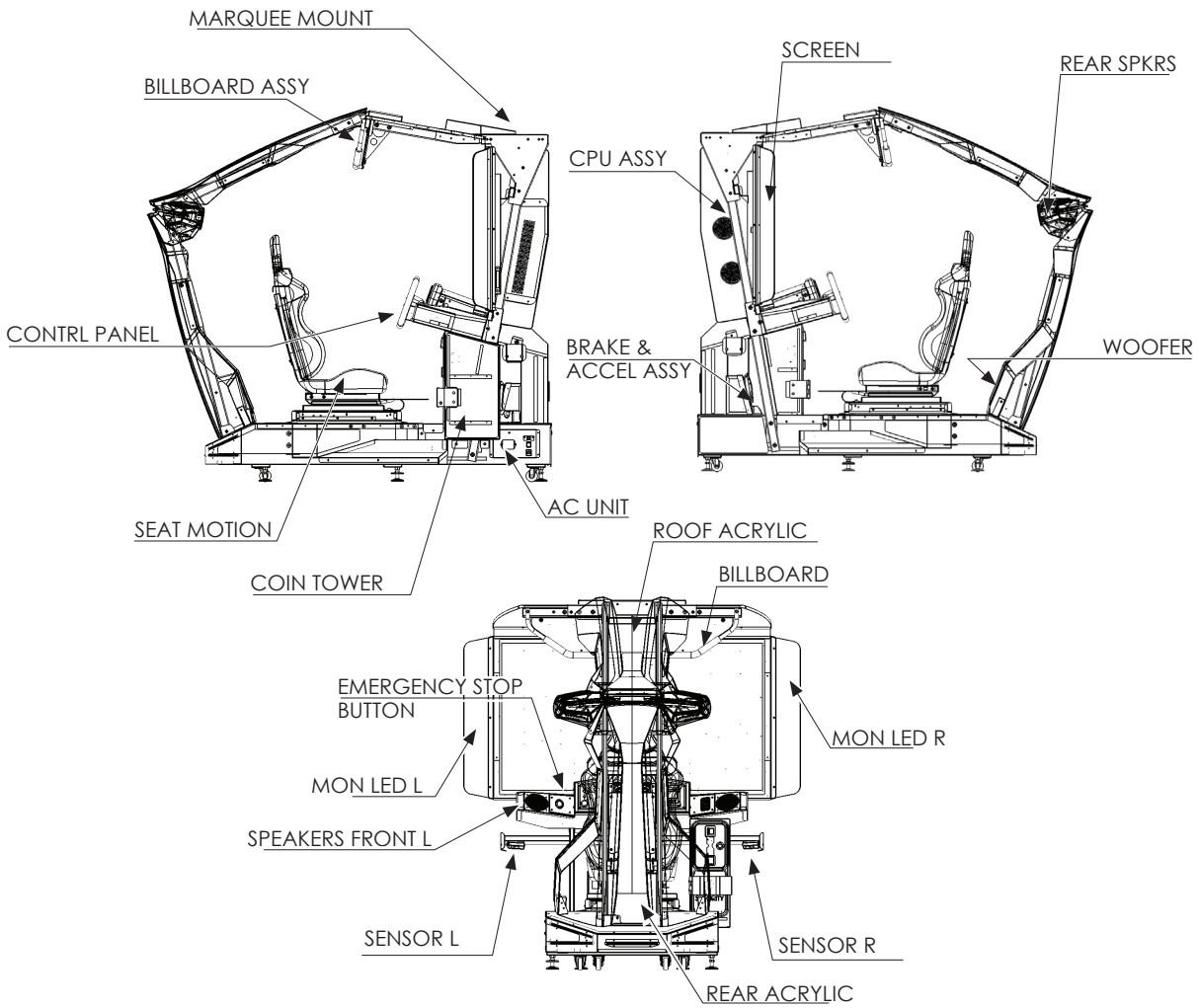

MARQUEE

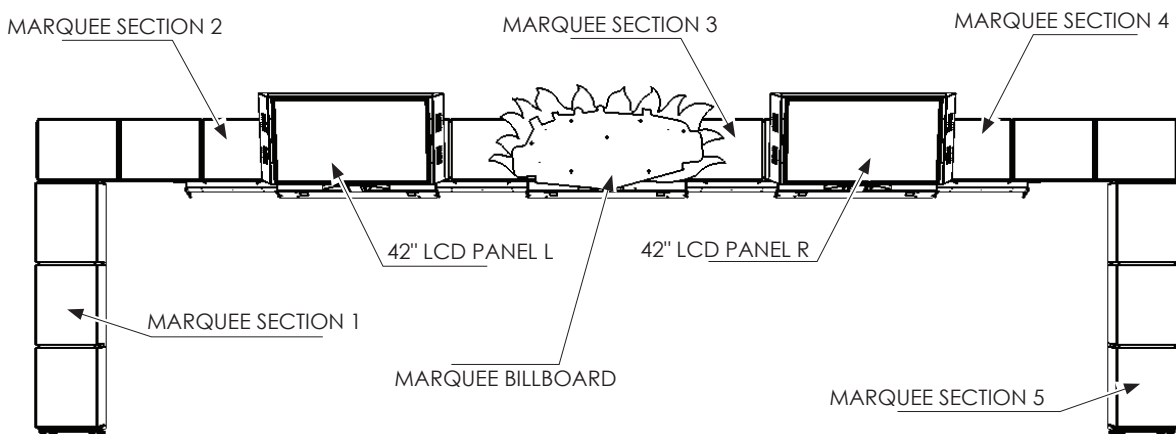

5 ACCESSORIES

Confirm that the accessories listed in the table below are present when setting up the product. Accessories marked “Spare” in the note column are consumable items but included as spares.

TABLE 5a

OWNER’S and SERVICE MANUAL
420-0023-01UK (1)
This manual

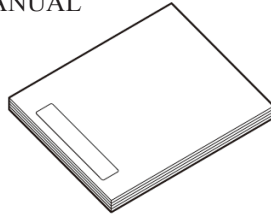

KEY
(2)
For the cashbox door
(Located inside the coin chute door at time of shipment)

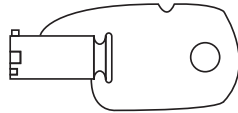

KEY
(2)
For the Projector Box
(Located inside coin chute door or within the Installation Kit)

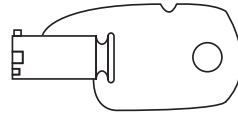

POWER CABLE
LM1227 (1) <UK>
LM1246 (1) <European>
LM1550 (1) <America>
For installation, see chapter 6

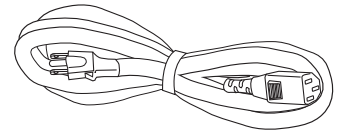

MASTER KEY
220-5575UK (2)
For opening/closing the doors
(Packaged with this manual, in the box supplied with the product)

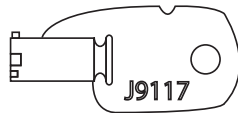

STICKER SHEET C EPILEPSY MULTI
440-CS0186UKUK (1)
Multilingual caution label - epilepsy seizure
(English version fitted as standard)
Please see chapter 1 for label positioning.



The parts listed in Table 5b are needed to finalise the installation. These are traditionally parts that are applied by the customer at location. Please take a moment to check the contents. If for some reason some the parts are not present then please call your local office along with the machine serial number to arrange for the relevant parts to be sent to you. (PLEASE NOTE THAT SOME ITEMS ARE ALREADY FITTED TO LOCATION TO AID INSTALL)

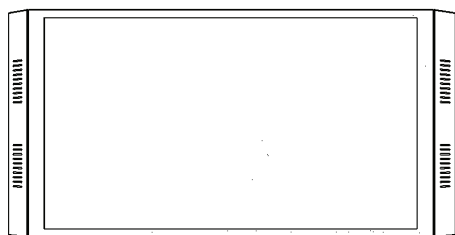

DSD-5100UK
ASSY LCD MON 42" (2)

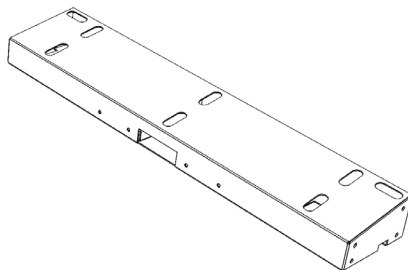

DSD-5030UK
CABINET BRACE (3)

DSD-5020UK - GANTRY MAIN SECTION (1)

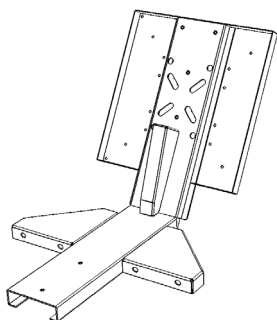
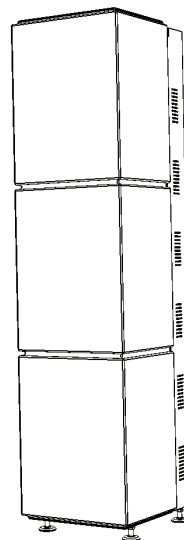

DSD-9620UK
MONITOR STAND (2)

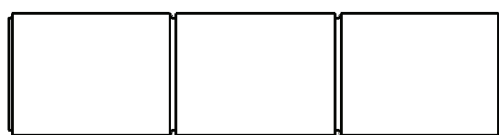

DSD-5025/6/7/8UK - GANTRY CUBE SECTION (4)

DSD-5050UK - GANTRY SLAVE SECTION (1)

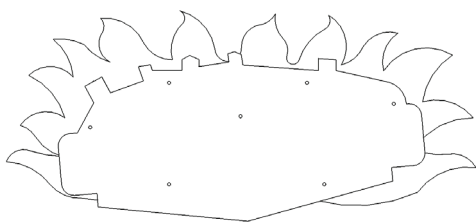
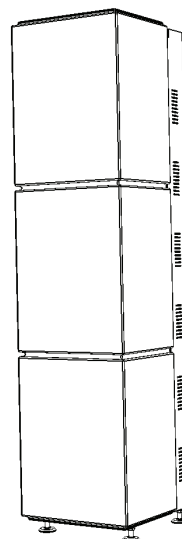

DSD-5200K
BILLBOARD (1)

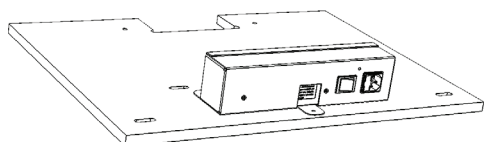

DSD-9620UK
GANTRY DIST BOARD (1)

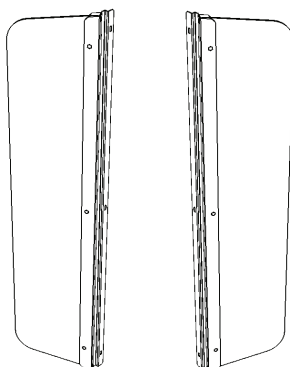

DSD-9620UK DSD-9625UK
ASSY SCREEN SIDE L (1) ASSY SCREEN SIDE R (1)

TABLE 5b

| | PART NUMBER | DESCRIPTION | QTY |
|-----|---------------|-------------------------|-----|
| 1 | DSD-0004XUK | BRKT LOCK PIVOT ARM | 2 |
| 2 | DSD-0007UK | HEADER PNL L | 1 |
| 3 | DSD-0008UK | HEADER PNL R | 1 |
| 5 | 280-6696UK | 5.5-20X6.3 WSHR SPCL AL | 4 |
| 6 | DSD-3314-01UK | STICKER MOULD BACK NO1 | 1 |
| 7 | DSD-3314-02UK | STICKER MOULD BACK NO2 | 1 |
| 8 | DSD-3314-03UK | STICKER MOULD BACK NO3 | 1 |
| 9 | DSD-3314-04UK | STICKER MOULD BACK NO4 | 1 |
| | | | |
| 101 | 020-000620-OZ | M6X20 SKT CAP OZ | 6 |
| 102 | 060-S00600-0B | M6 WSHR SPR BLK | 6 |
| 103 | 068-652016-0B | M6 WSHR 200D FLT BLK | 6 |
| 104 | 020-000820-OZ | M8X20 SKT CAP OZ | 2 |
| 105 | 060-S00800-0B | M8 WSHR SPR BLK | 2 |
| 106 | 068-852216-0B | M8 WSHR 220D FLT BLK | 2 |
| 107 | 020-0S0510 | M5X10 SKT CAP STNLS | 4 |

6 ASSEMBLY AND INSTALLATION

WARNING

- Perform assembly work by following the procedure herein stated. Failure to comply with the instructions can cause electric shock.
- Perform assembling as per this manual. Since this is a complex machine, incorrect assembling can cause an electric shock, machine damage and/or improper functioning as per specified performance.
- When assembling, more than one person is required. Depending on the assembly work, there are some cases in which working by one person alone can cause personal injury or parts damage.
- Ensure that connectors are properly connected. Improper connections can cause electric shock.
- Be careful not to damage the wires. Damaged wires may cause electric shock or short circuit or present a risk of fire.
- This work should be carried out by site maintenance personnel or other qualified professionals. Work performed by non-technical personnel can cause a severe accident such as electric shock. Failing to comply with this instruction can cause a severe accident such as electric shock to the player during operation. If no one with proper technological expertise is available, request service from the office indicated in this document or the point of purchase so as to ensure safety.
- Provide sufficient space so that assembling can be performed. Performing work in places with narrow space or low ceiling may cause an accident and assembly work to be difficult.
- To perform work safely and avoid serious accident such as the cabinet falling down, do not perform work in places where step-like grade differences, a ditch, or slope exist.
- Do not leave power cords or ground wires exposed in areas of heavy foot traffic. Doing so may cause them to become damaged, possibly resulting in electric shock and/or short circuits. When laying wiring across the floor, always use safety covers to protect the wires. (Wiring diameter: power cable - approx. \varnothing 8)
- Have a flashlight or another supplementary lighting unit available while working. With indoor lighting alone, the cabinet interior may be too dark. Working without proper lighting can lead to accidents. It also hinders proper work performance.
- The cabinet has ventilation ports. Be sure not to block them. If they are blocked, heat can build up, leading to fire. This can also accelerate wearing of parts and malfunctions.
- Secure ample ventilation space around the cabinet. If heat builds up, there could be accidents associated with heat or smoke generation.
- This product does not use any connectors other than those connected to and used by the game board when it leaves the factory. Do not needlessly connect wires to unused connectors. This could lead to overheating, generation of smoke and burn related injuries.

CAUTION

- Handle molded parts with care. Excessive weight or pressure may cause them to break and the broken pieces may cause injury.
- To perform the operation safely and accurately you must use a safe, steady footstool or stepladder. Working without this may lead to a fall and possible injury.
- Attempting to forcefully connect the incorrect connector or connecting a connector at the wrong angle or facing may damage the connector and could lead to overheating and burn related injuries.
- When attaching or removing doors or lids, be careful that your hand or finger does not get caught in anything.

IMPORTANT

- Be very careful when handling the Projector screen. The screen can be damaged easily and cannot be repaired once damaged. Such damage can only be repaired by completely replacing the screen.
- Be careful not to damage parts surfaces. In some cases, if such surfaces are damaged, the part must be replaced; it cannot be reinforced or repaired.

The assembly of this product is performed in the following 12 steps.

- 6.1 UNPACKING THE CABINET.
- 6.2 ATTACHING SIDE LED TO MONITOR.
- 6.3 POSITIONING AND INSTALLING THE CABINETS.
- 6.4 FITTING THE MARQUEE BLOCKS.
- 6.5 FITTING THE BILLBOARD PLATE.
- 6.6 CONNECTING THE MARQUEE.
- 6.7 FITTING THE 42" DISPLAYS.
- 6.8 CONNECTING THE CAMERAS.
- 6.9 LINKING THE CABINETS (COMMUNICATION PLAY)
- 6.10 APPLYING THE COVERS.
- 6.11 APPLYING THE POWER.
- 6.12 CONFIRMATION OF INSTALLATION,

Tools Required for Assembly Operation

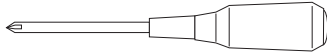

- Philips screwdriver (for M4, M6 screws)

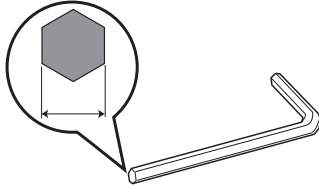

- Hex Drive for (M4, M6 & M8 screws)

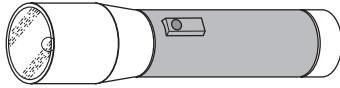

- A touch or any additional lighting

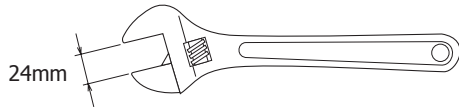

- A wrench or 24mm Spanner.

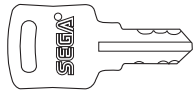

- A Master Key

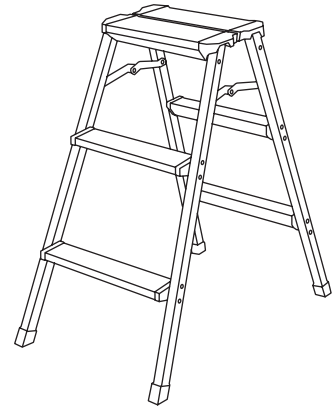

Locking Step Ladders -

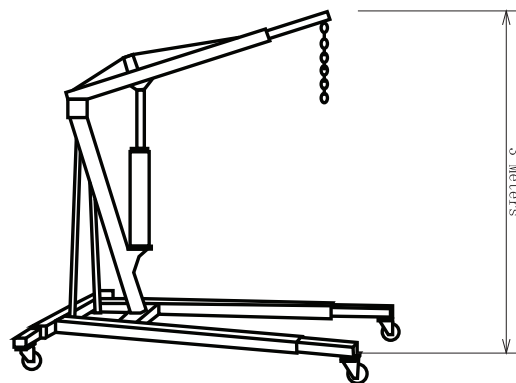

- Lifting equipment capable of lifting to a height of 3m and 60Kg in weight.

6-1 UNPACKING THE CABINET

STOP IMPORTANT

- Be very careful when removing the Monitor and Seat cabinets from the pallet. Use only hydraulic lifting equipment such as a fork lift. The machine weighs in excess of 350kgs. DO NOT attempt to remove the machine from the pallet by hand. Doing so may result in serious personel injury and/or damage to the cabinet and its components.
- There are 4 “LIFTING POINTS” highlighted on the lower front and rear parts of the machine by a  symbol. Always use these points when lifting.

In this product each cabinet is delivered as a single unit and therefore removed from the pallet as one piece. Take care when removing the machine from it's pallet. Only use appropriate lifting equipment such as a Fork Truck or similar lifting equipment.

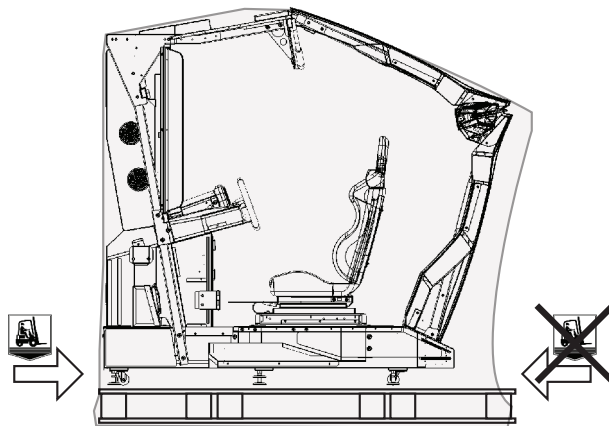

FIG. 6-1a

Carefully remove the outer packaging and lift the machine from it's pallet using a Fork Truck or similar industrial lifting equipment.

When removing the cabinet off it's pallet, always enter it from either end and not the sides.. Entering for the sides will be obstructed by the 2 horizontal beams running along the full length of the Pallet.

Once removed from its Pallet base, raise the (6) Leg Adjusters so that the casters come in to contact with the floor. This will enable free movement of the machine to enable setting out the correct location.

IMPORTANT

Ensure that the Leg Adjusters are raised enough to combat with slightly uneven surfaces.

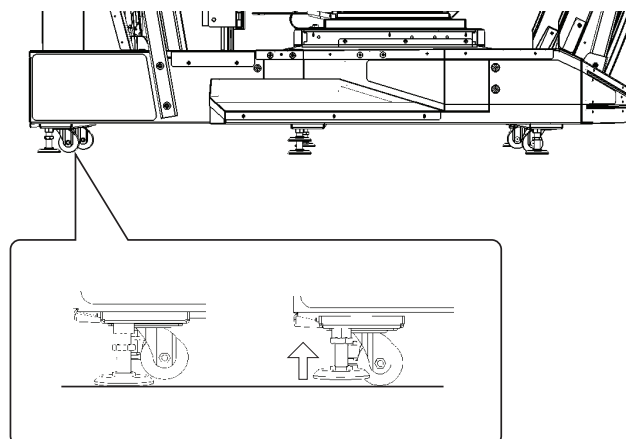

FIG. 6-1b

Removing the Transit Brackets.

STOP IMPORTANT

- The **YELLOW Transit Bracket MUST be removed before applying power!**. Failure to remove the Transit Bracket before power is applied will cause damage and electronic failure to the cabinet.

Each cabinet is fitted with a **YELLOW** transit bracket which is attached to the rear of the cabinet to prevent the seat from moving whilst in transit! These must be removed before applying power.

- 1 Locate the Transit brackets at the rear of each cabinet.

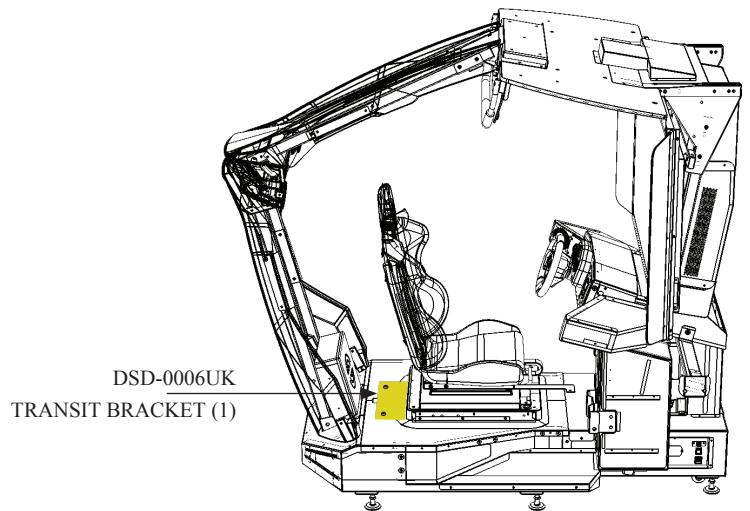

- 2 Unscrew the 2 M8x16 Socket cap bolts and remove. Do not discard the brackets of the fixings as they may be required when relocating the machine.

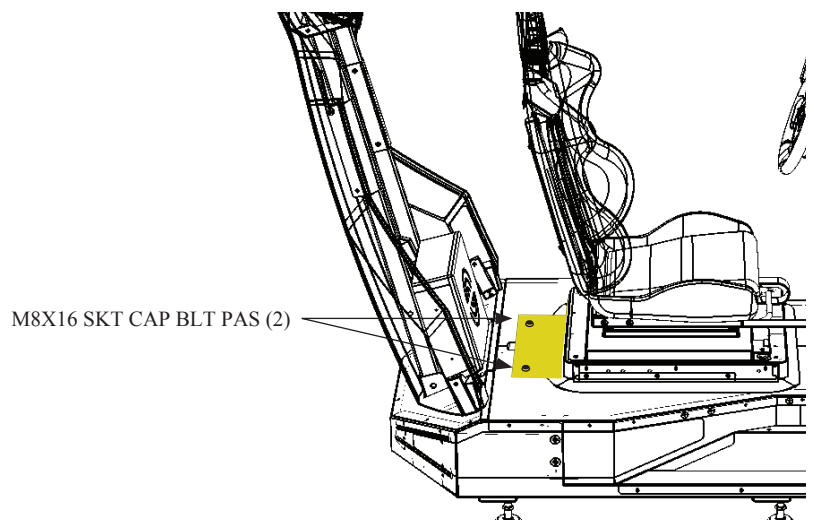

6-2 ATTACHING THE SIDE LED TO THE MONITOR

⚠ CAUTION

- Handle molded parts with care. Excessive weight or pressure may cause them to break and the broken pieces may cause injury.
- Some aspects of this operation may require two people to ensure that the work is carried out safely. Do not begin to carry out this work if no more than one person is available.
- When working at height, always use either a stool or stepladder. Have another person stabilize the equipment before stepping onto it to begin the work. Failure to secure either ladders or stool may cause in an accident and result in injury and/or damage to the machine.

Make sure you provide enough space to work safely. Please refer to Installation Precautions section earlier in this manual.

- 1 Unpack the 4 cabinets and begin to attach the Monitor side LEDs DSD-9620UK and DSD-9625UK.

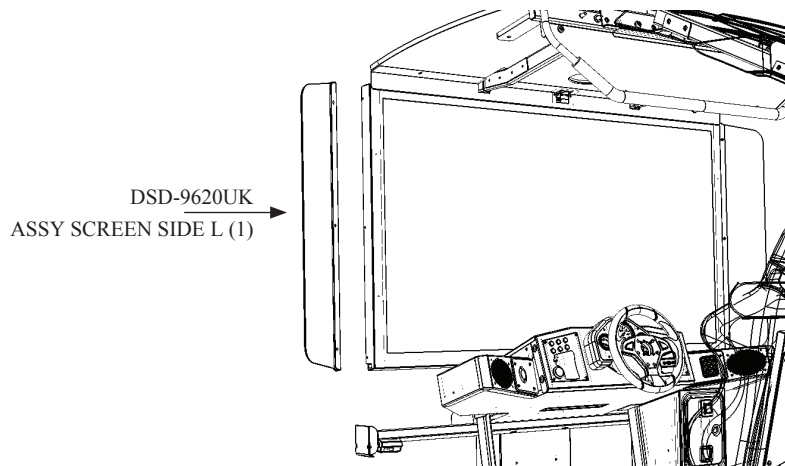

FIG. 6-2a

- 2 Before fixing the ASSY LED be sure to connect the LED harness and to feed it back into its channel so that no wires are exposed.

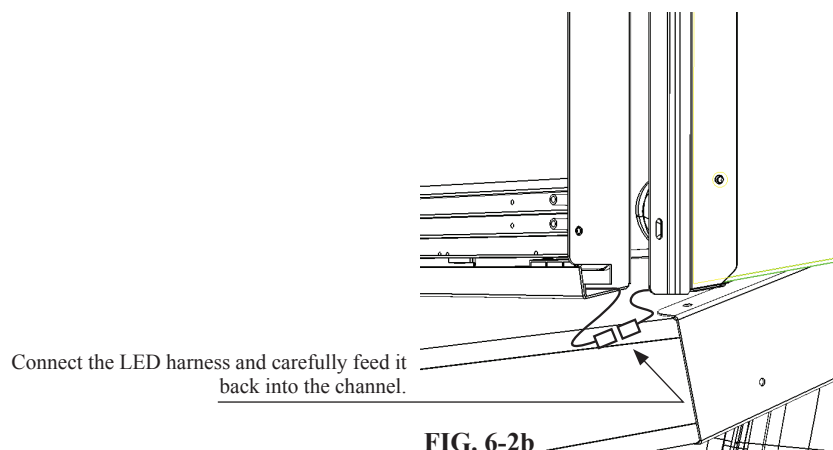

FIG. 6-2b

- 3 Offer the ASSY LED into position and using a PHILIPS screwdriver secure with M4X12 MSCR BLK (3)

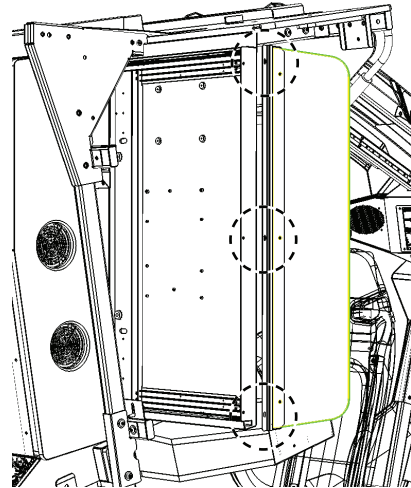

FIG. 6-2c

- 4 Repeat the process on the opposing side and on the remaining 3 caninets.

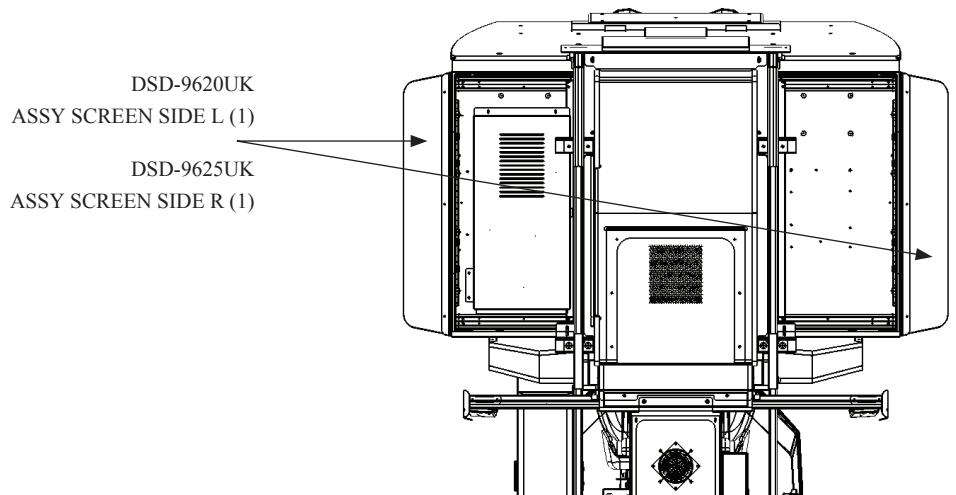

FIG. 6-2d

6-3 POSITIONING & INSTALLING THE CABINETS

It is important that a suitable location is secured to enable installation to be carried out safely.

Please refer the begining of this manual for weights and dimensions.

- 1 Carefully position the (4) car units into position. Once connected together it will not be possible to move. Be sure that the location is correct prior fixing. Position Car units in sequence starting with Car 1 on the left.

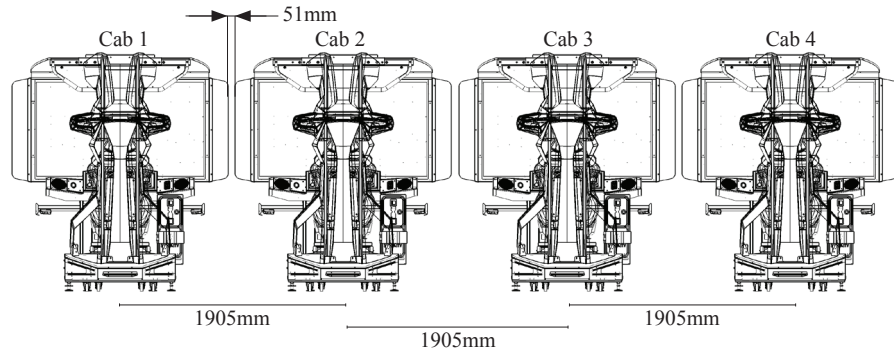

FIG. 6-3a

- 2 Each Car Unit comes with its own MARQUEE BLOCK SUPPORT. Make sure that the correct BLOCK SUPPORT is fitted to the correct CAR UNIT.

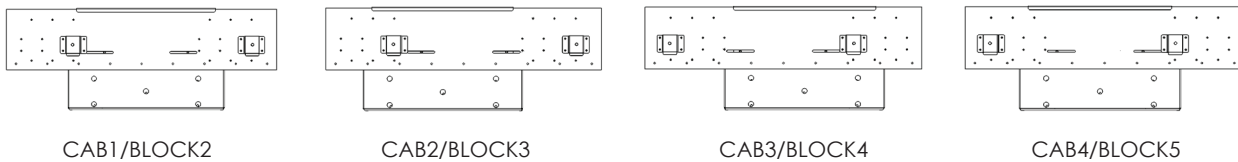

FIG. 6-3b

- 3 Using a minimum of two people and a set of Step Ladders or Stool, Place the correct MARQUEE SUPPORT BLOCKS onto the corresponding cabinets

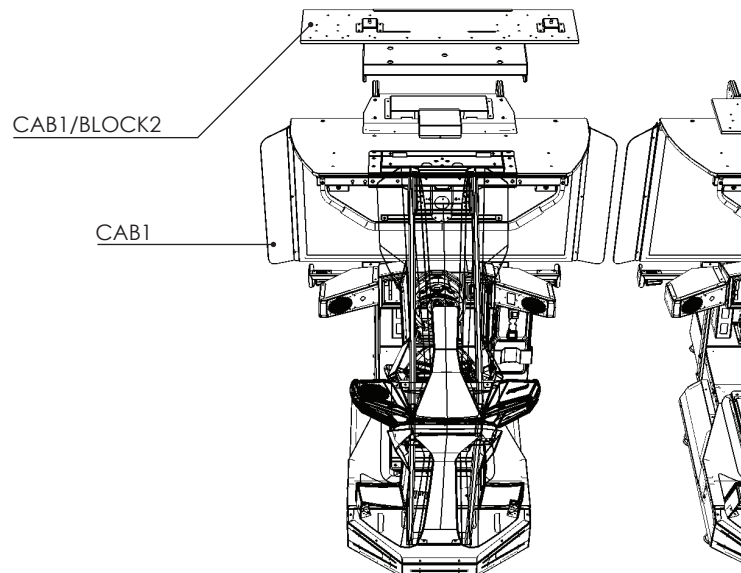

FIG. 6-3c

STOP IMPORTANT

- Take extra care when working from height. Some pieces are in excess of 10Kg. Make sure that you do not work alone and that another person is on hand to aid in installtion.
- Take note of the positions and the locations of each MARQUEE BLOCK SUPPORT. If not set correctly the LIGHTING BLOCKS will not fit into place.

4 Place all (4) MARQUEE BLOCK SUPPORTS on their corresponding cabinets and secure into place using (5) M8x40 INT HEX BOLT BLK.

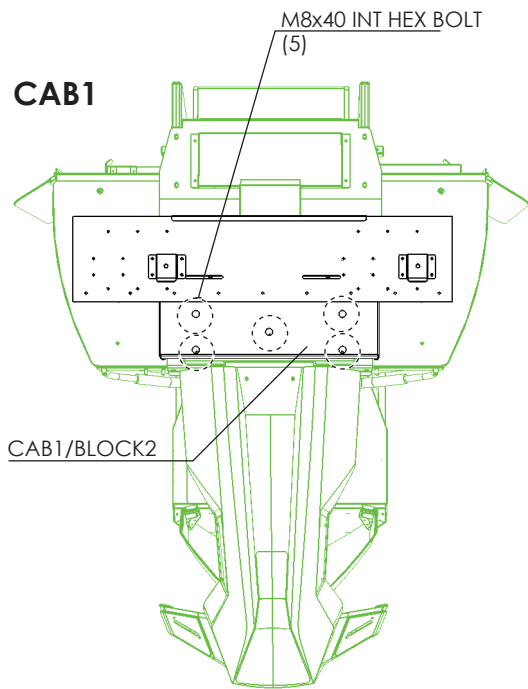

FIG. 6-3d

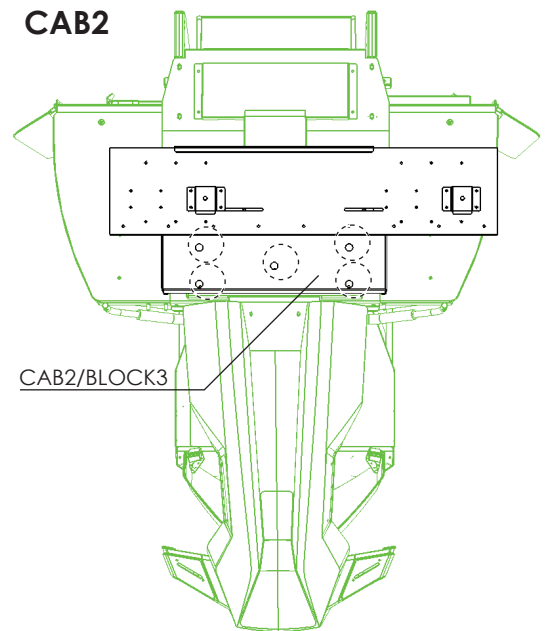

FIG. 6-3e

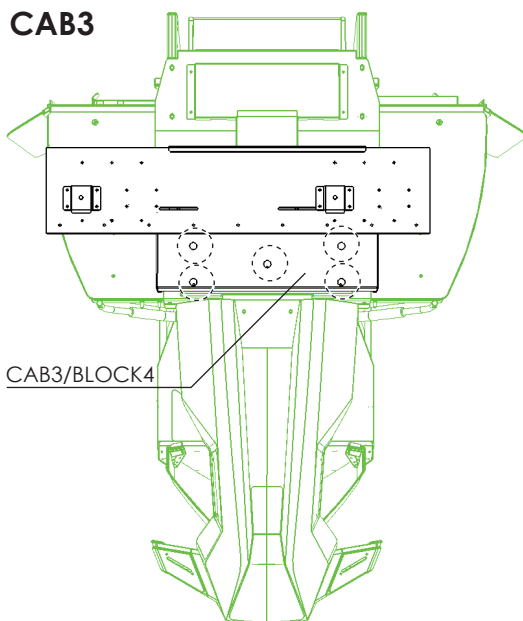

FIG. 6-3f

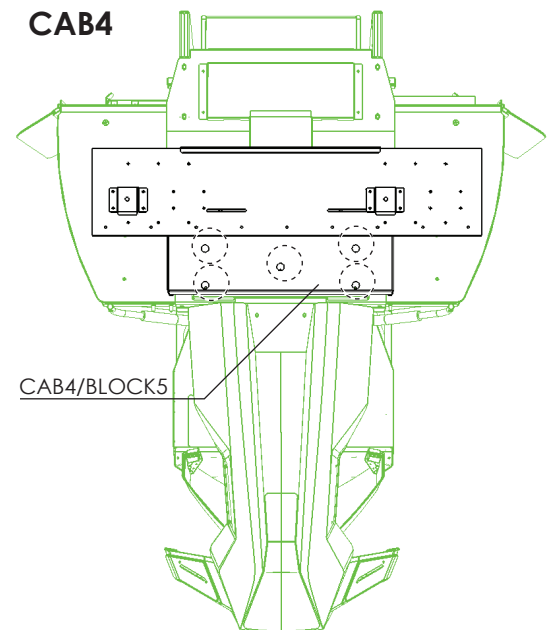

FIG. 6-3g

5 Once all (4) MARQUEE BLOCK SUPPORTS have been fixed into position you can now begin to fit the (3) MOUNT LED ASSYs.

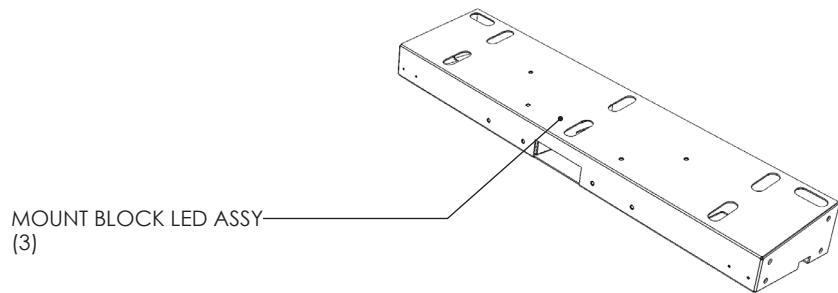

FIG. 6-3h

6 Using (2) people and secure step ladders, place the first of the three MOUNT BLOCK LED ASSYs in the centre between CAB2 and CAB3 as shown.

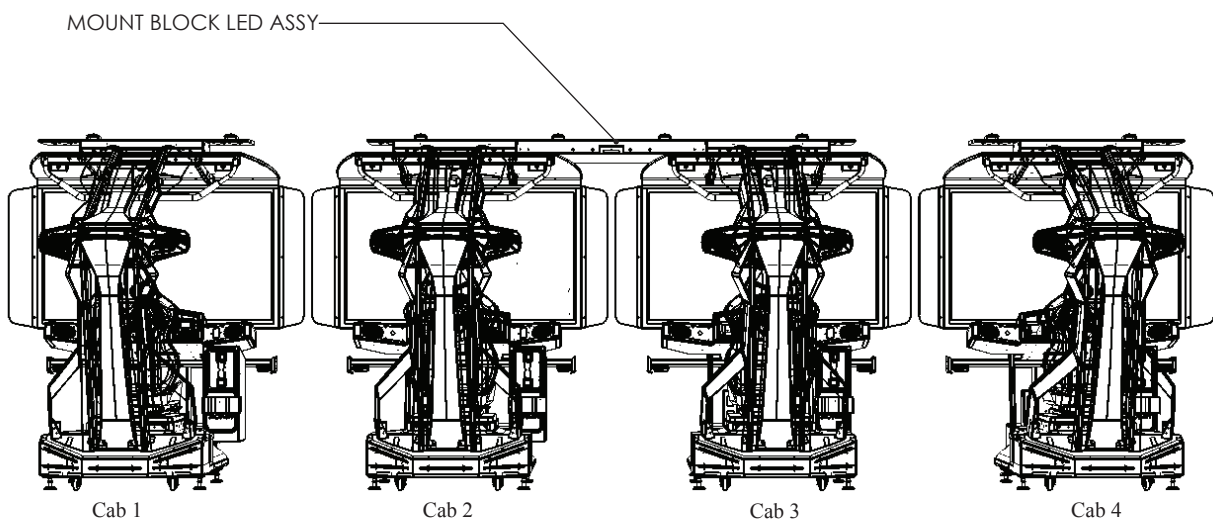

FIG. 6-3i

7 From the back of the cabinets secure the MOUNT BLOCK LED ASSY into position using (12) M8x

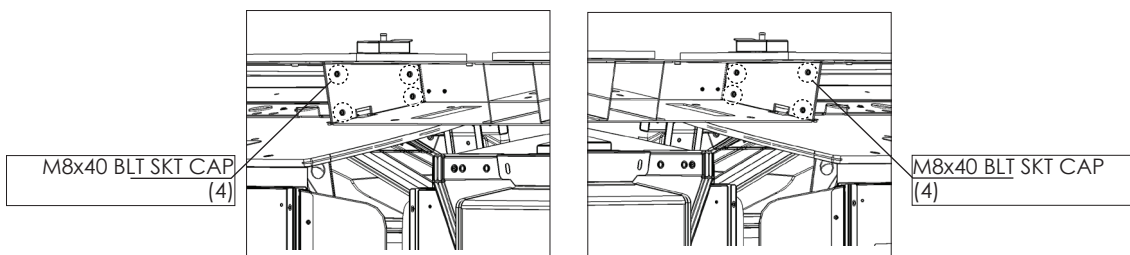

FIG. 6-3j

FIG. 6-3k

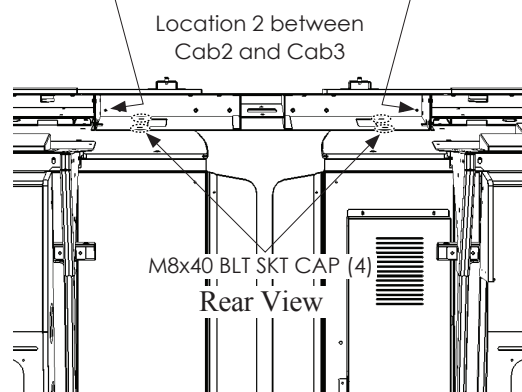
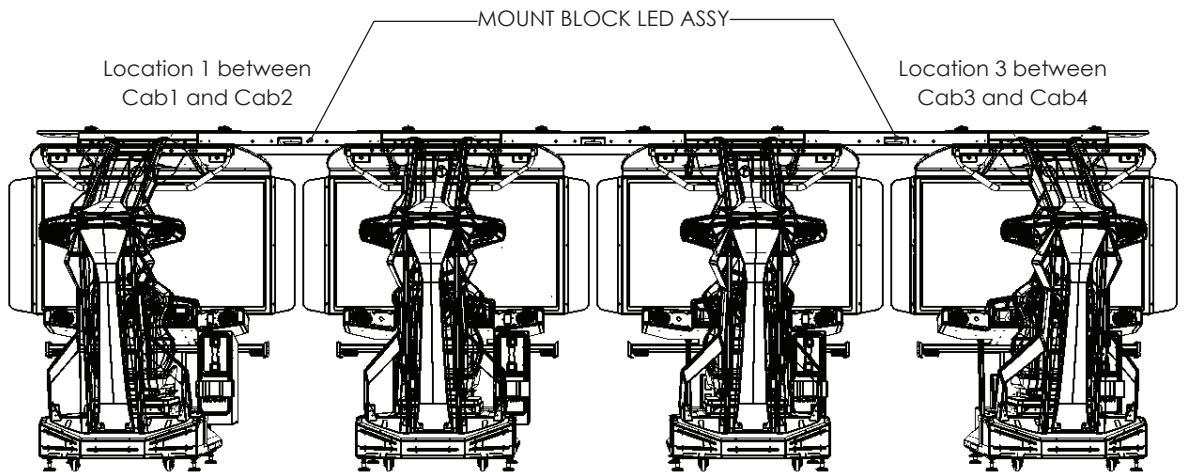
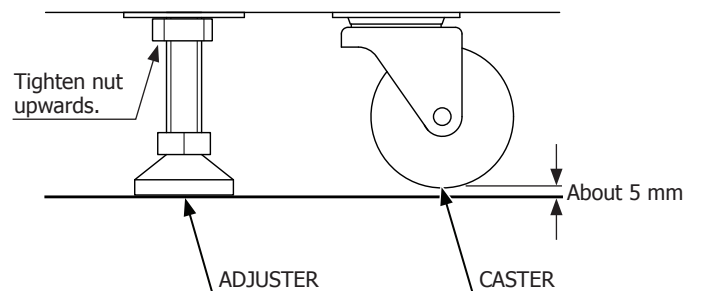
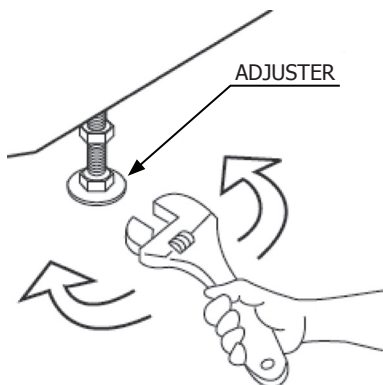
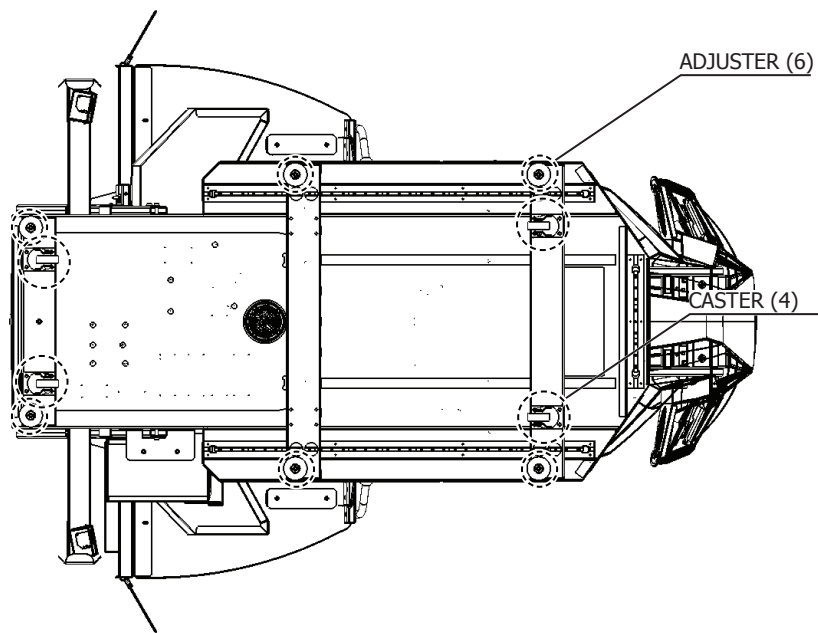

FIG. 6-3l

8 Repeat step 6 and 7 to position and secure the MARQUEE BLOCK SUPPORTS in locations 1 and 3.



9 Once all four (4) cabinets are braced together. Bring the adjusters into direct contact with the floor. Use a wrench to align the height of the adjusters until the cabinet is perfectly level. After setting, turn adjuster nuts upwards to tighten them and secure adjuster heights.



6-4 FITTING THE MARQUEE BLOCKS

It is important that a suitable location is secured to enable installation to be carried out safely.
Please refer the beginning of this manual for weights and dimensions.

STOP IMPORTANT

- Be very careful when handling moulded parts.
- Be careful not to damage parts surfaces. In some cases, if such surfaces are damaged, the part must be replaced; it cannot be reinforced or repaired.
- The MARQUEE BLOCKS are HEAVY! Be sure that you do not attempt to lift without the aid of another. It is recommended that 3 people aid to place the MARQUEE BLOCKS onto the cabinets.

1 Position Blocks 1 and 6 at either end of the (4) cabinets.

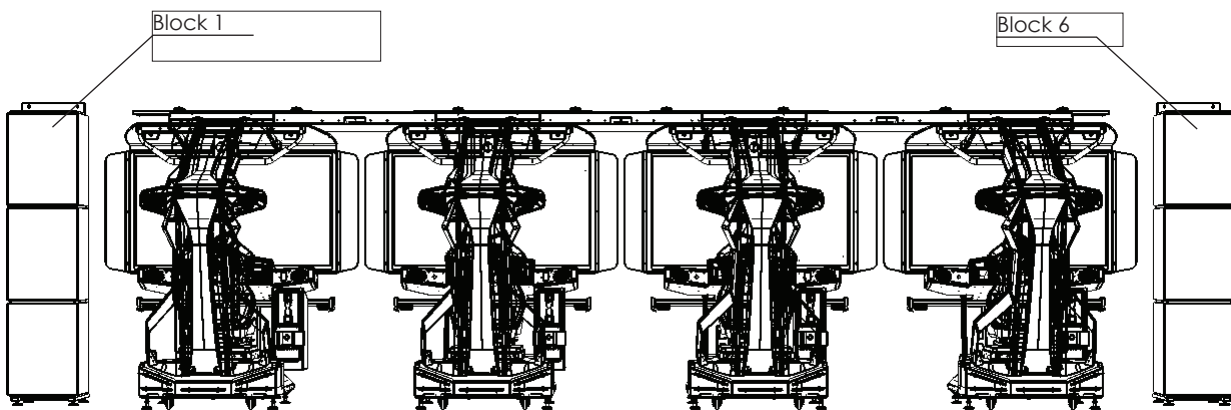

2 Safely using (3) people, offer Block 3 up to Cabs 1 and 2.

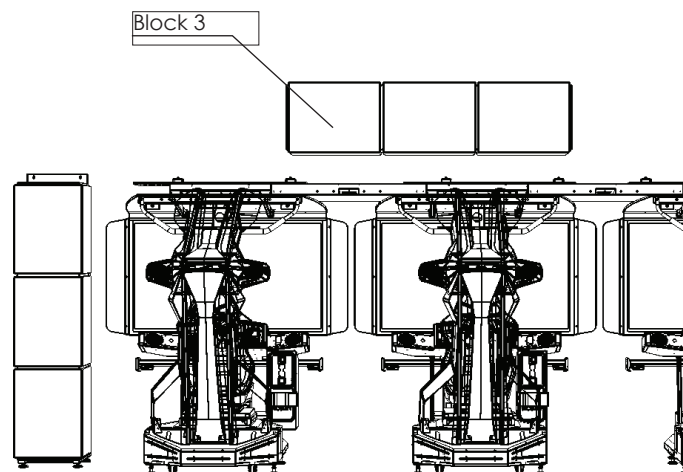

- 3 Safely using (3) people, offer Block 3 up to Cabs 1 and 2 and carefully slide the locating brackets into the receiving latches until it “clicks” and locks into place.

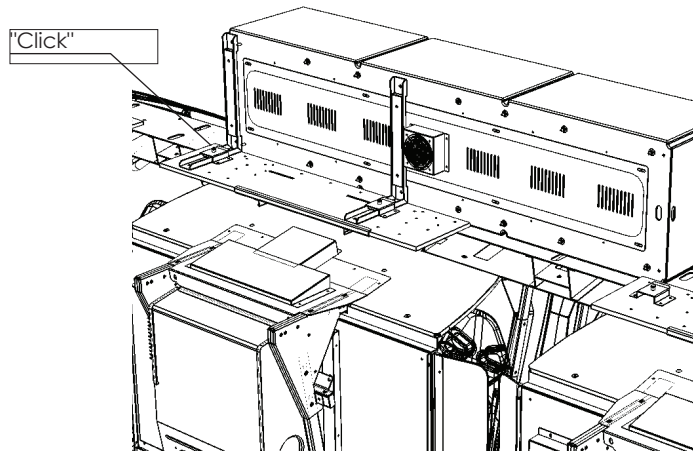
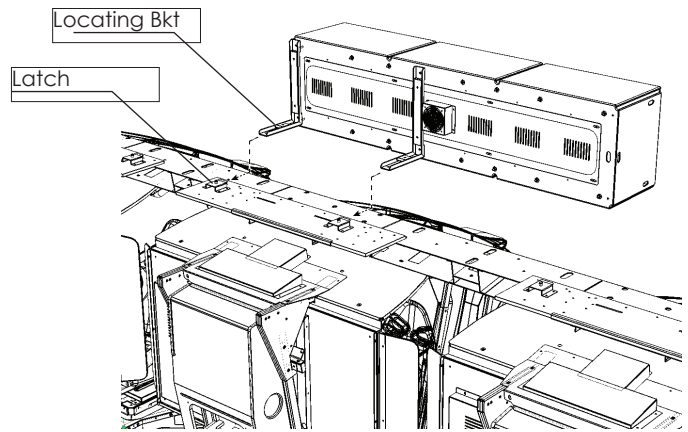

- 4 Following the same method as step 3 Safely using (3) people, offer Block 4 up to Cabs 3 and 4 and carefully slide the locating brackets into the receiving latches until it “clicks” and locks into place.

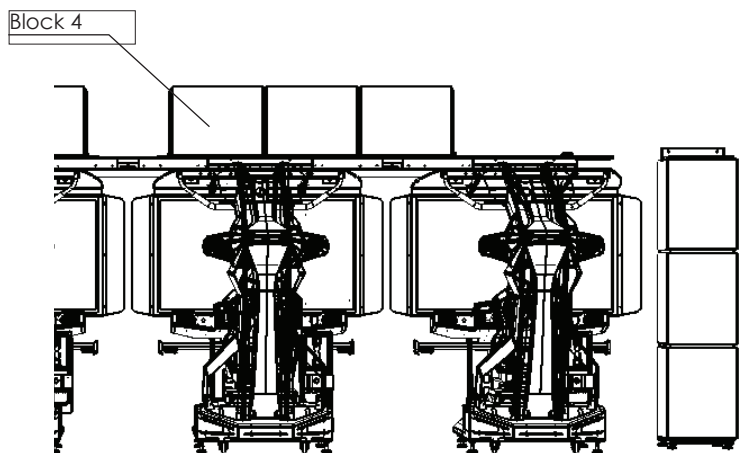

- 5** Following the same method as step 3 Safely using (3) people, offer Block 2 up to Cabs 1 and carefully slide the locating brackets into the receiving latches until it “clicks” and locks into place.

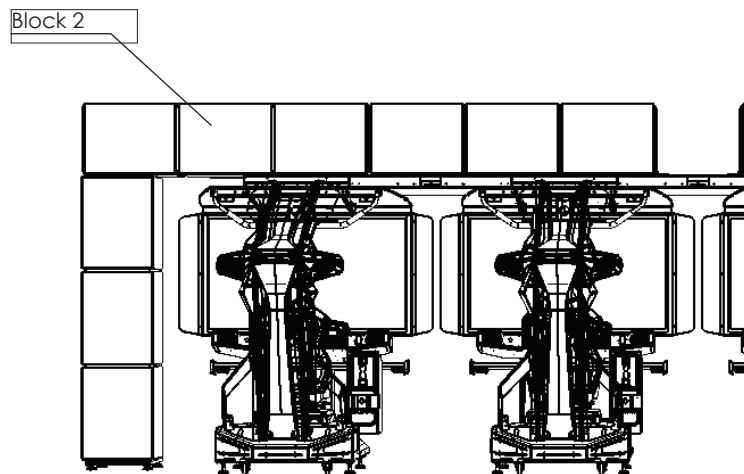

- 6** Once Block 2 is locked into place add the additional (2) M6 Flanged Nut joining Blocks 1 and 2

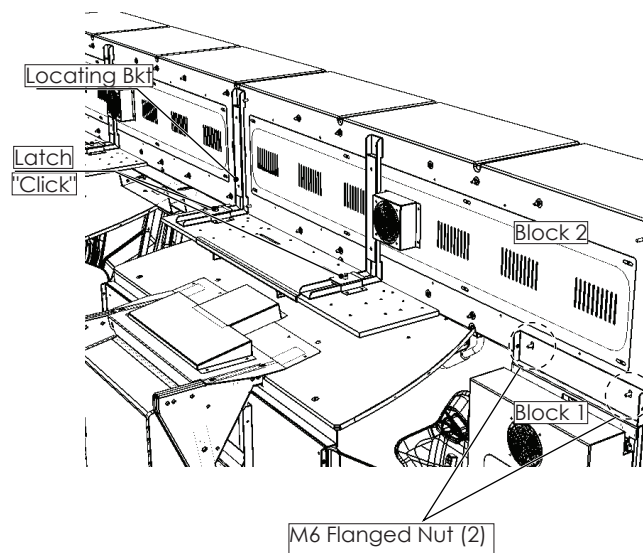

- 7** Repeat step 6 utilising Block 5. Once Block 5 is locked into place add the additional (2) M6 Flanged Nut joining Blocks 1 and 2

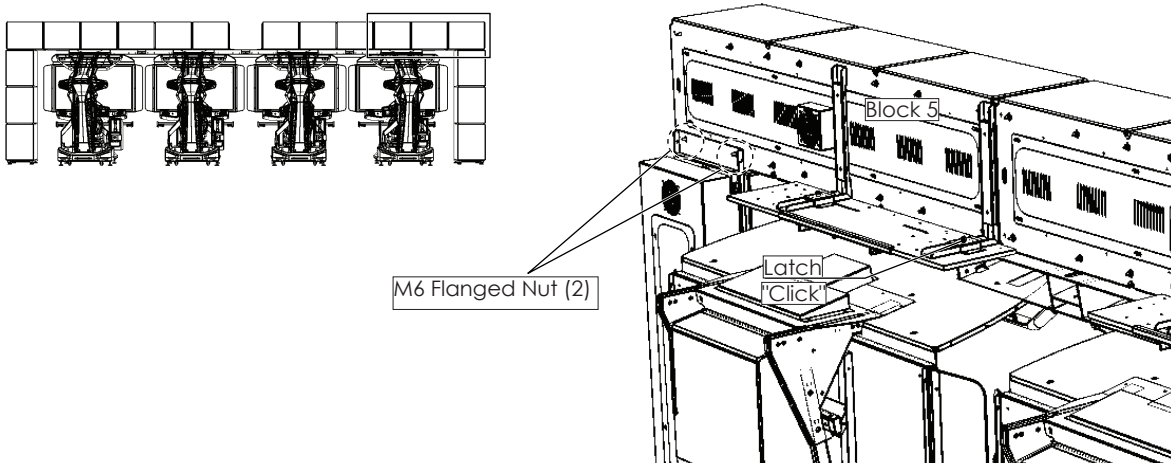

- 8 Before securing the Block into position, make sure that the gap between Blocks 3 and 4 is between 580mm and 600mm.

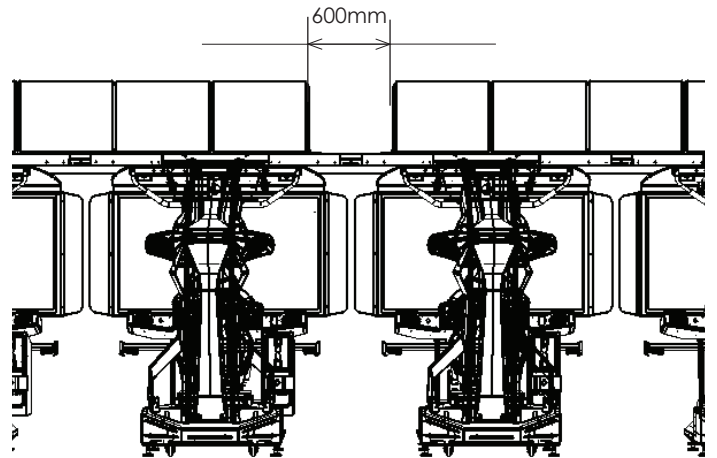

- 9 Once the correct gap has been achieved only then secure each Block into position.

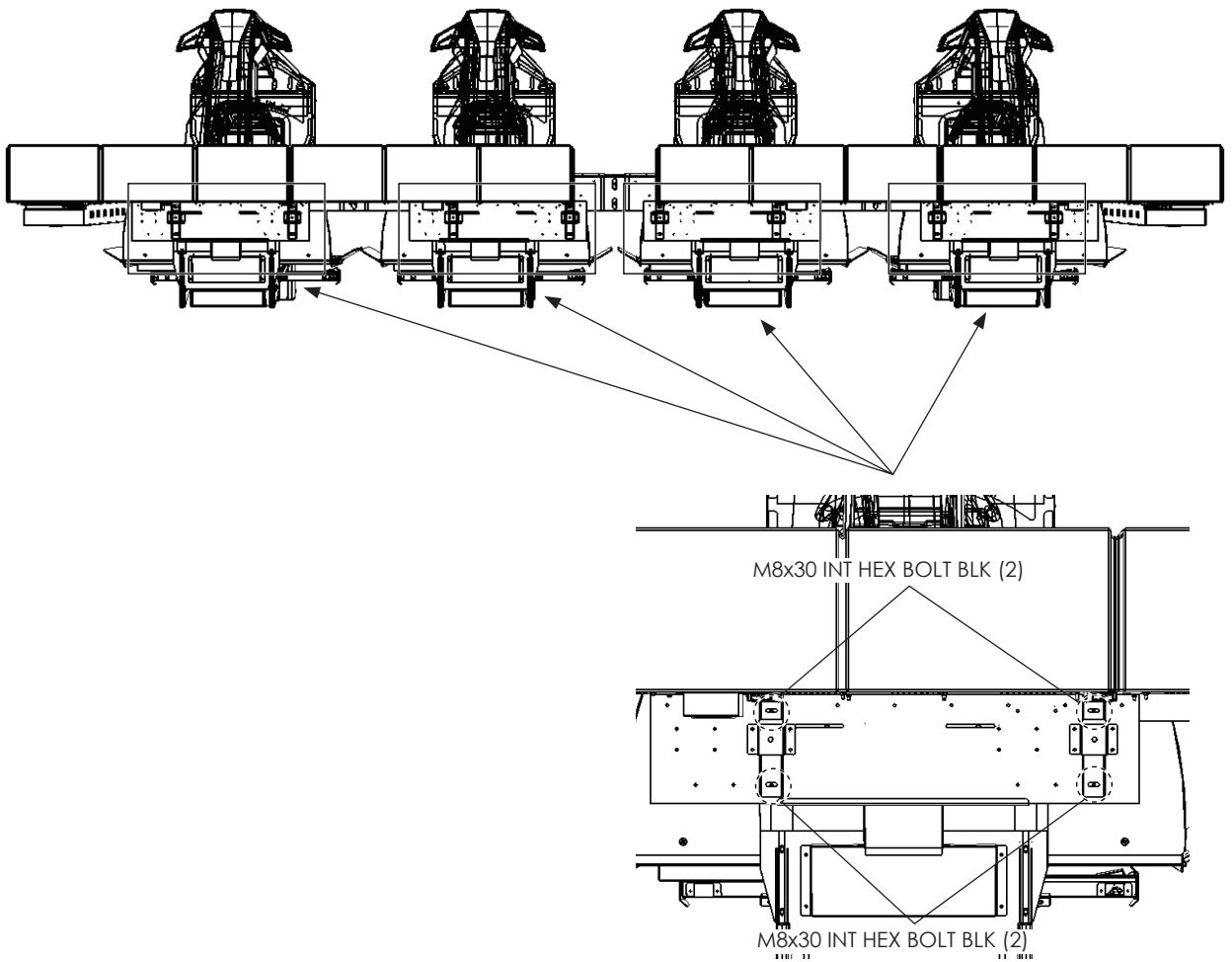

6-5 FITTING THE BILLBOARD PLATE

There are connections to be made between each of the 6 Blocks. Please follow these instructions which highlight the number of connections to be made and their locations.

1 Fit the Billboard Plate onto the Billboard Support Bkt

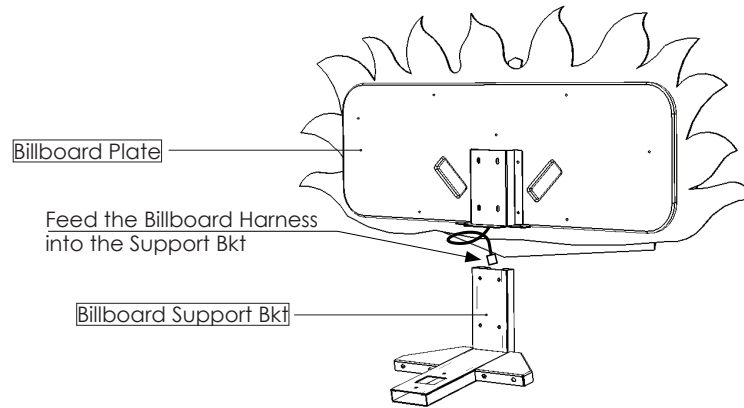

2 Secure the Billboard Plate to the Billboard Support Bkt using (4) M6x20 Hex Bolts

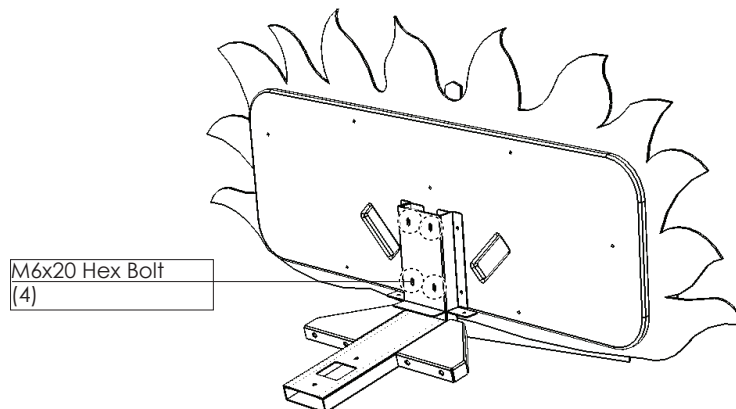

3 Using 2 people, raise the Assy Billboard and carefully slide it into the allocated slot in the centre of the Marquee.

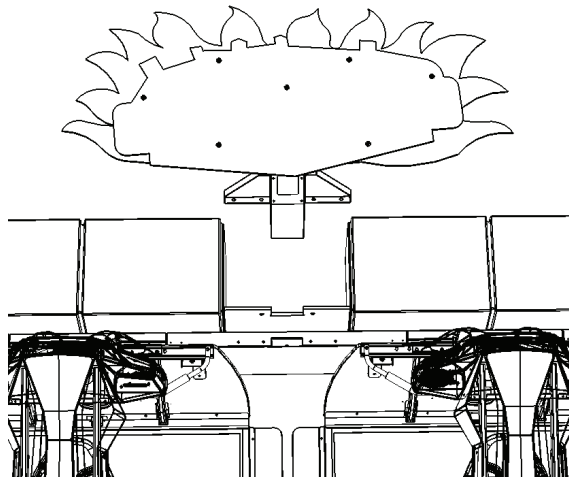
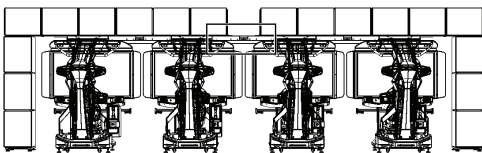

- 4 Using 2 people, raise the Assy Billboard and carefully slide it into the allocated slot in the centre of the Marquee.

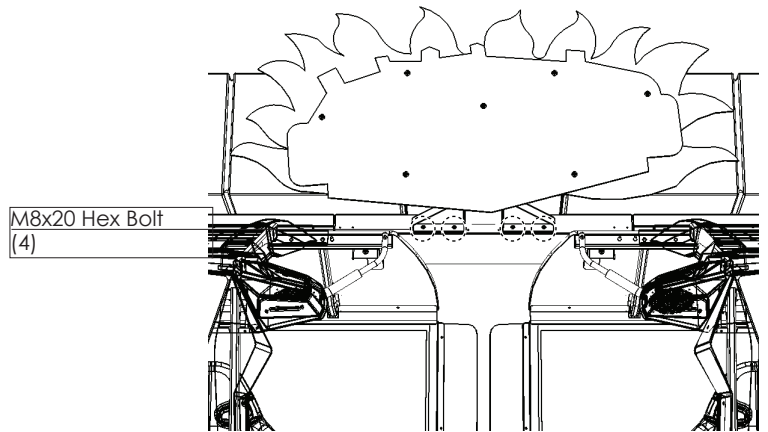

6-6 CONNECTING THE MARQUEE

There are connections to be made between each of the 6 Blocks. Please follow these instructions which highlight the number of connections to be made and their locations.

- 1** First connections to be made are between Blocks 1 and 2. There are 6 connections to be made. Make sure each connector is firmly pushed into its receptacle and locked into place.

6 Connections

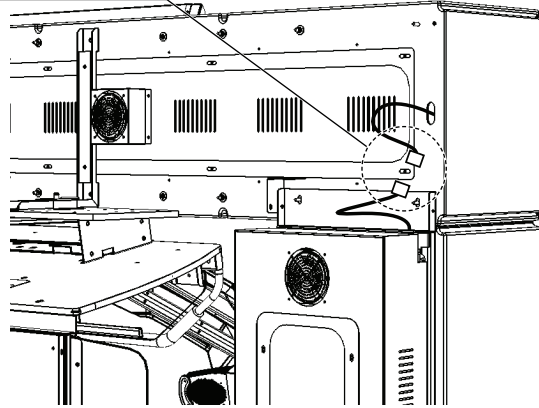

- 2** Next make the connections between Blocks 2 and 3 following the same principles as step 1. There are 5 connections to be made between Blocks 2 and 3.

5 Connections

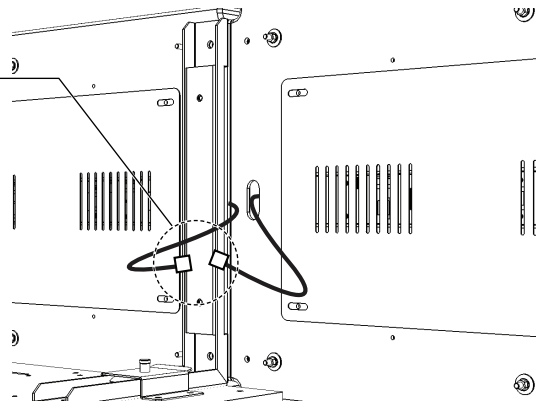

- 3** Next make the connections between Blocks 3 and 4 following the same principles as step 1. There are 3 connections to be made between Blocks 3 and 4. Feed the connection to the Billboard into the Billboard Support Bracket.

3 Connections

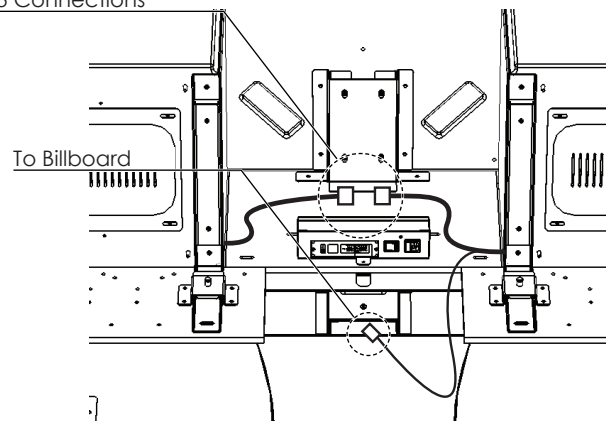

4 Next make the connections between Blocks 4 and 5 following the same principles as step 1. There are 3 connections to be made between Blocks 4 and 5.

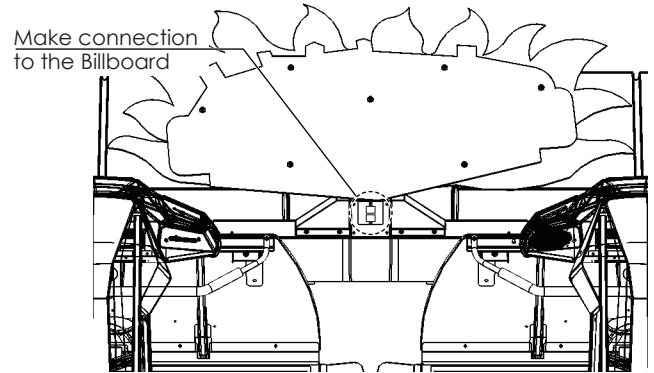

5 Next make the connections between Blocks 4 and 5 following the same principles as step 1. There are 3 connections to be made between Blocks 4 and 5.

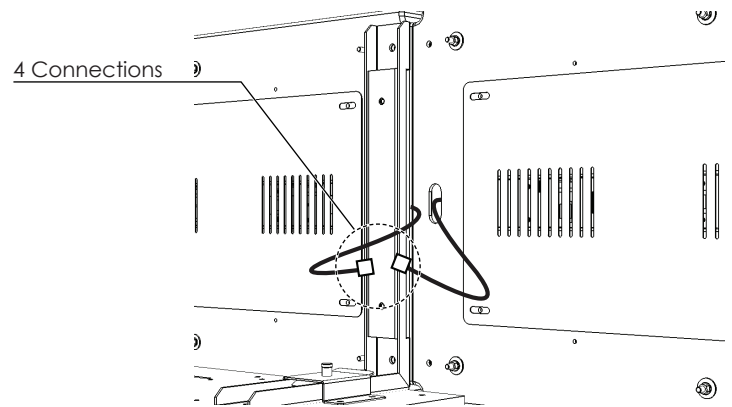

6 Next make the connections between Blocks 5 and 6 following the same principles as step 1. There are 3 connections to be made between Blocks 5 and 6.

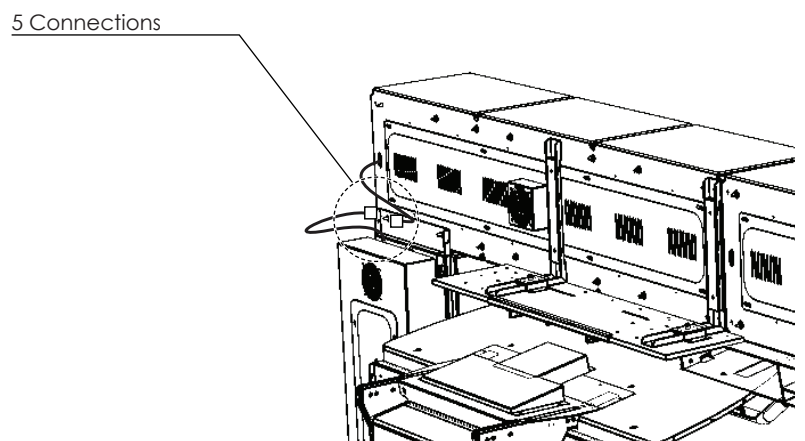

6-7 FITTING THE 42" DISPLAYS

Please follow these instructions to safely install the (2) 42" LCD displays and ASSY BILLBOARD into the Marquee.

STOP IMPORTANT

- Be very careful when handling heavy items.
- Be careful not to damage parts surfaces. In some cases, if such surfaces are damaged, the part must be replaced; it cannot be reinforced or repaired.
- The 42" LCD DISPLAYS are HEAVY! Be sure that you use lifting equipment such as a Telescopic hoist or High Rise Platform
- DO NOT attempt to instal single handedly.

- 1 Both Power and Video Cables are already attached to the Monitor Assy and are located at the rear of the Monitor placed between the Outer Support Bkt and the Monitor casing.

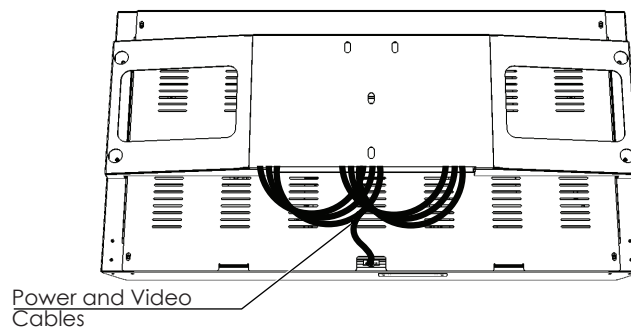

- 2 Remove the Power and Video cables from between the Monitor casing and Support Bracket and carefully slide the Assy Disp Mount up into the recess on the back of the 42" LCD Display.

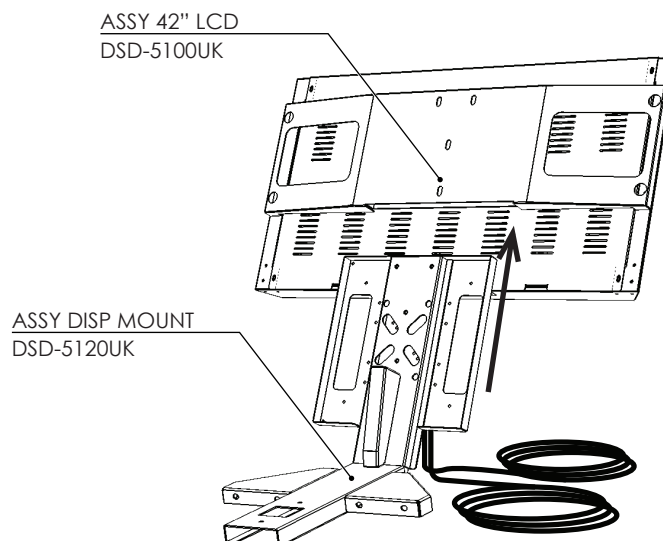

- 3** Secure the 42" LCD Display to the Disp Mount using (4) M8x16 Internal Hex Bolts Black.

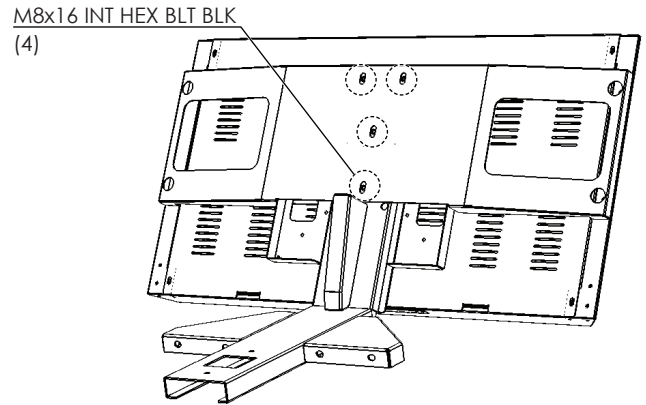

- 4** Using a hoist to aid lifting, position the first screen in front of Blocks 2 and 3 and carefully slide into position.

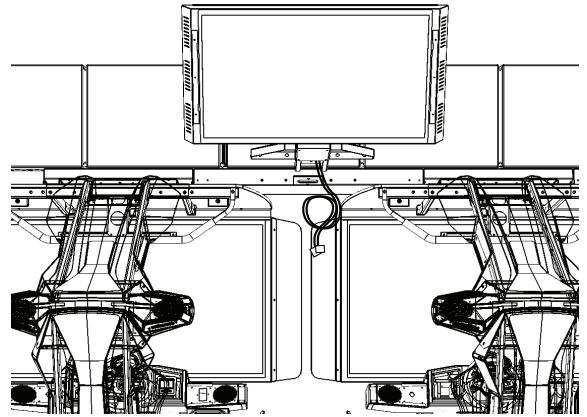
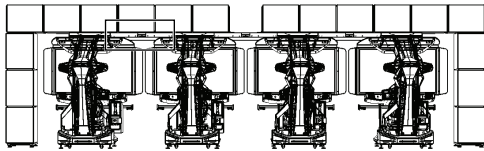

- 5** Once in position, secure using (4) M8x20 SKT CAP BLT BLK, (4) M8 SPRING WSHR (4) M8 WSHR. Feed the VIDEO and POWER harness in through the access point within the Support Bracket.

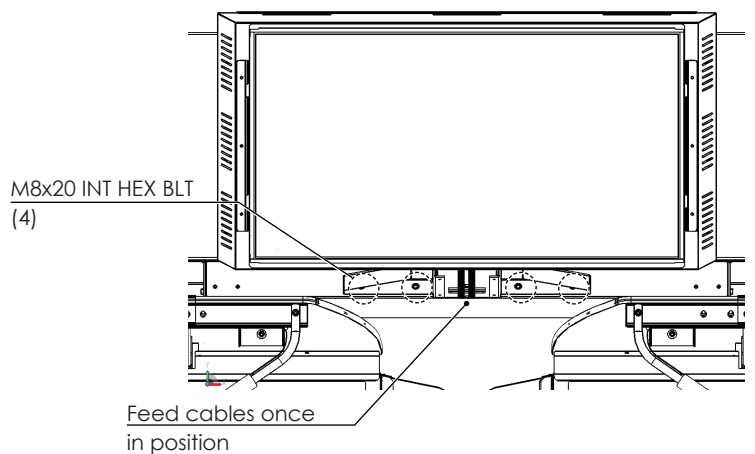

- 6** Repeat steps 1 to 4 to attach the second Monitor.

CONNECTING THE DISPLAYS

- 7** Route the Video cable out from the rear of the Monitor Support Bracket and feed it across the top of the cabinets toward the Left Hand Upright. Route the Power Cable towards the center of the Marquee towards the Billboard.

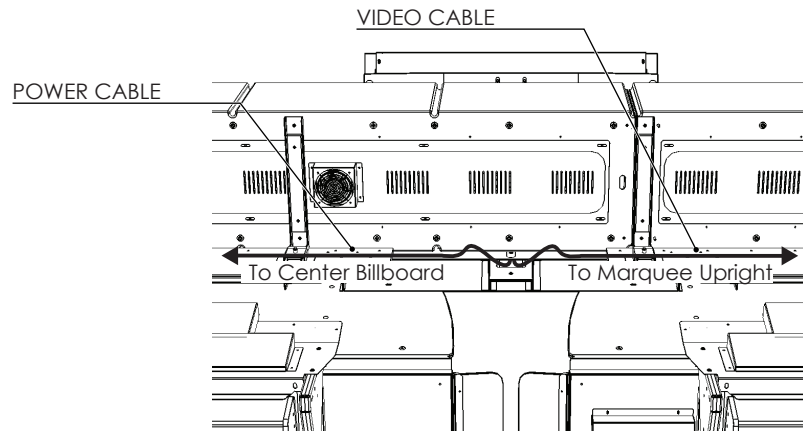

- 8** Connect the Power Cable into the rear of the IEC Distribution Block.

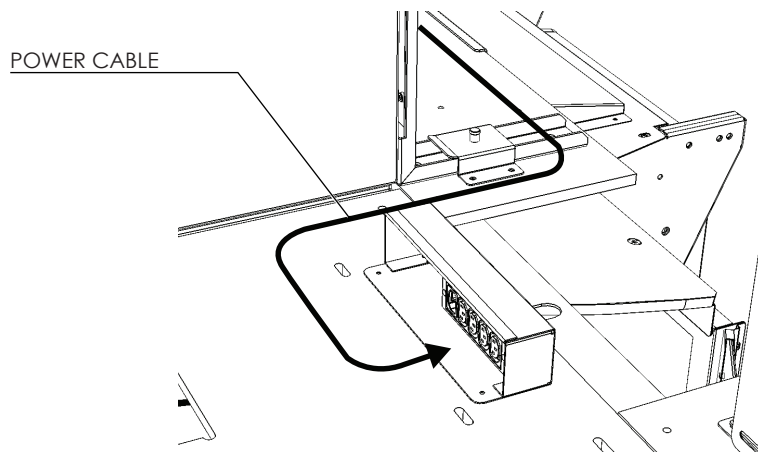

- 9** Remove the rear cover from the Left Hand Upright using a 10mm wrench or socket.

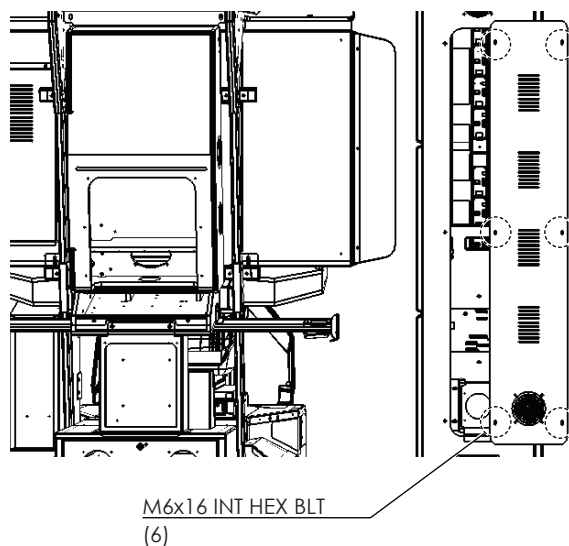

10 Route the Video Cable into the top of the Marquee Upright and feed it down towards the Video Splitter.

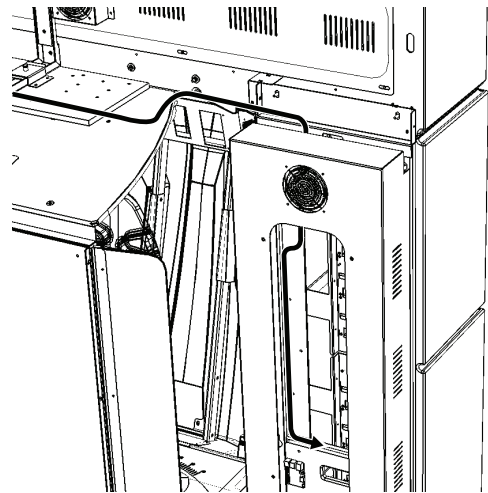

11 Connect the Left Hand Monitor into the Video Splitter and anchor the harness into the routers..

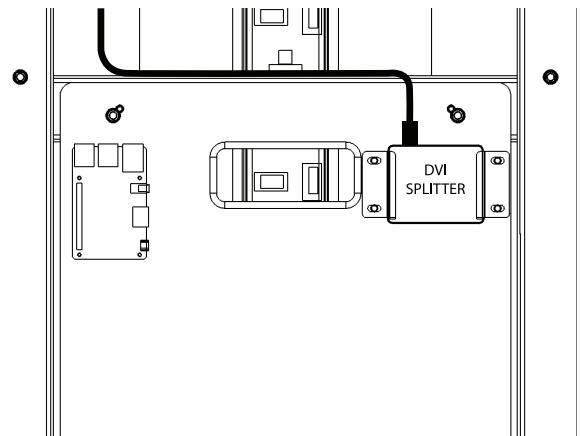

12 Feed both the Power and Video Cables from the Right Hand Monitor towards the center of the Cabinet and connect the Power harness into the same location as the Left hand monitor shown in Step 7

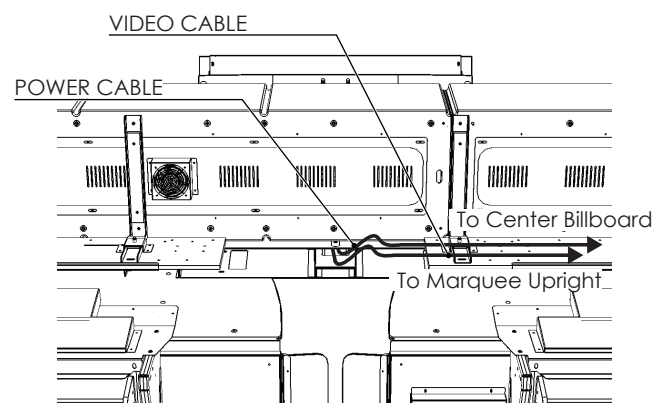

-
- 13** Continue to feed the Video Cable from the Right hand Monitor into the top of the Left Hand Upright as in Step 9.

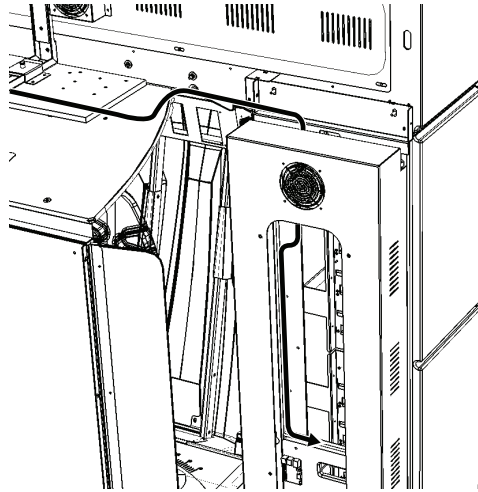

-
- 14** Finally, connect the Video Cable into the DVI Splitter along with the Video Cable of the Left Hand Monitor.

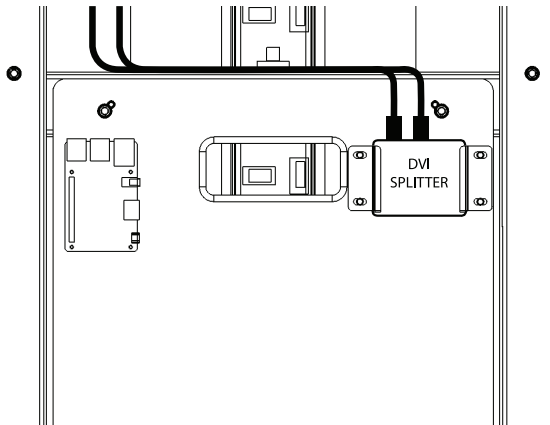

6-8 CONNECTING THE CAMERAS

Each of the (4) cabinets play host to a Video Camera which is housed above the screen. Please follow the instructions below to connect each Video Camera to the main controller within the Marquee.

- 1 Looking from the rear of the cabinet, remove the cover from the Right Hand Marquee upright.

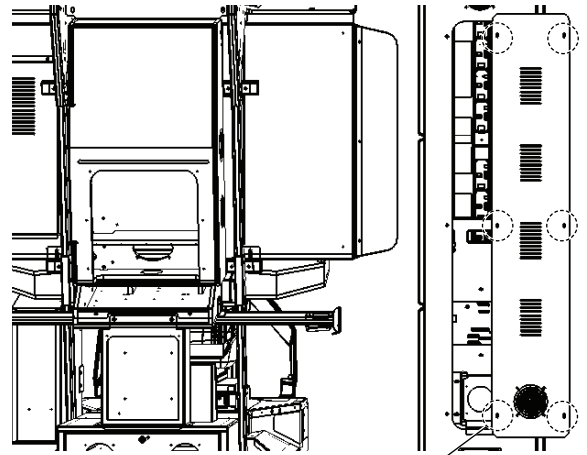

M6X16 INT HEX BLT
(6)

- 2 Using the (4) 10m Active USB cables (supplied), connect each camera to the corresponding ports on the PI Controller, each time feeding the cable into the top of the Marquee Upright.

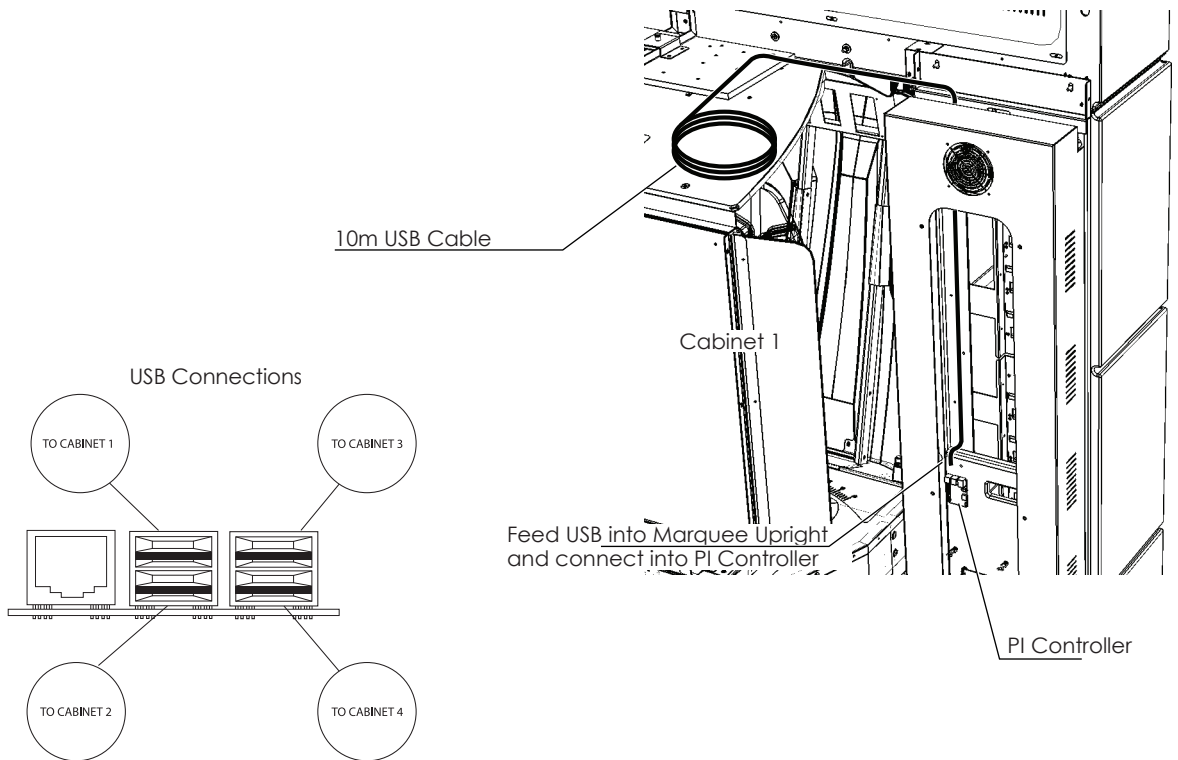

-
- 3** Run the USB CABLE EXT along the lower ledge of the Marquee, securing where available. Connect the USB CABLE EXT into the Camera USB.

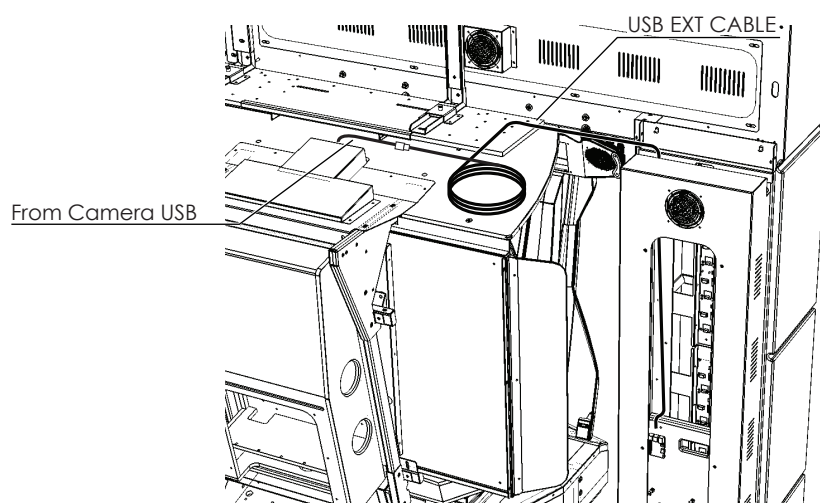

-
- 4** Follow steps 1 to 3 to connect all four cabinets. Making sure that the cables running between the PI Controller and the Cameras are anchored and are unable to fall loose.

6-9 LINKING THE CABINETS (COMMUNICATION)

Each of the (4) cabinets are linked via a HUB to allow upto a 4 player team game. Follow the instructions below to connect each cabinet.

- Using the (4) Lan Cables and the 4 PORT HUB (Supplied) connect each cabinet to the HUB via the AC Bracket mounted on the side of the cabinet.

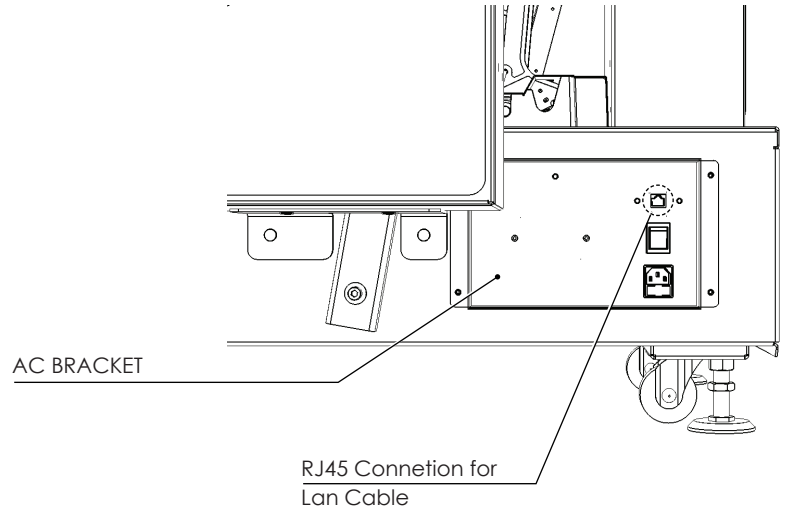

- Place a single Lan Cable into Cabinet 1 and for convenience place the oposing end into Position 1 on the Hub!.. Repeat with Cabinets 2, 3 and 4.

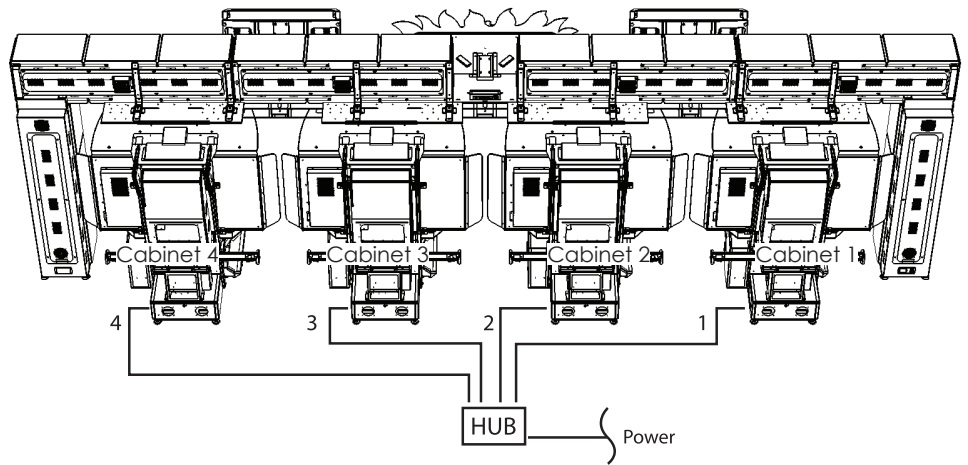

- Place the HUB up onto the Marquee Board and make the conneciton into the 3 PIN UK Mains Socket. DO NOT plug anything other that the HUB into this connection. When in position, Secure the Lan Cable into place using the harness routers along the rear of the Marquee.

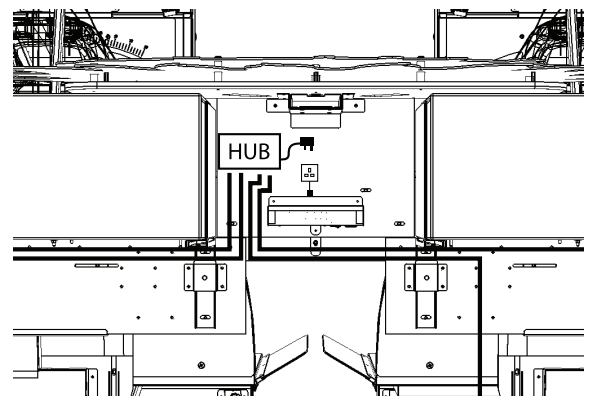

6-10 APPLYING COVERS

There are (6) covers on the rear of the Marquee and (2) covers on the front. Use these instructions as a guide to apply all (8) covers.

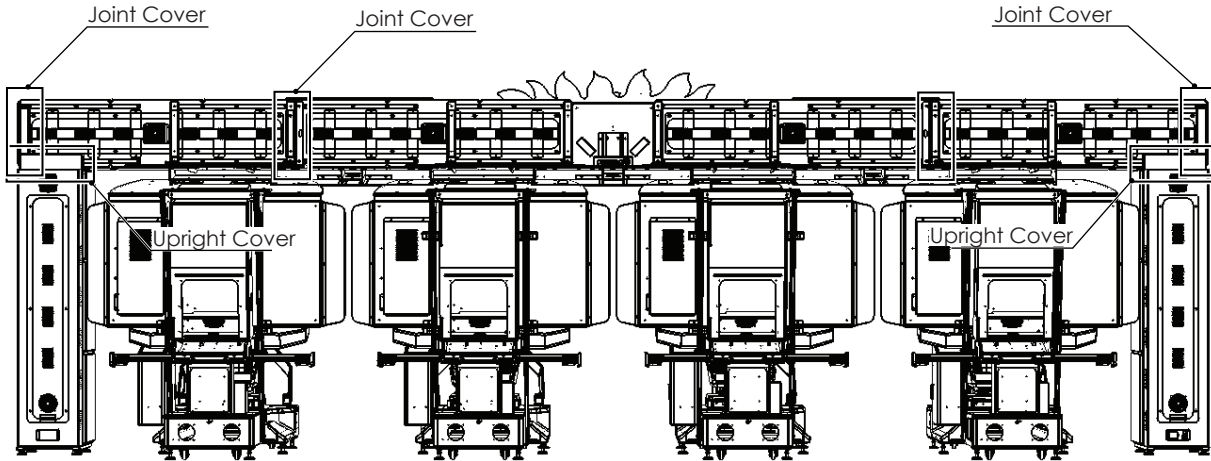

- 1 Applying the Joint Cover. Offer the JOINT COVER BKT to all of the 4 positions shown and secure using (4) M6x16 Hex Bolts Black.

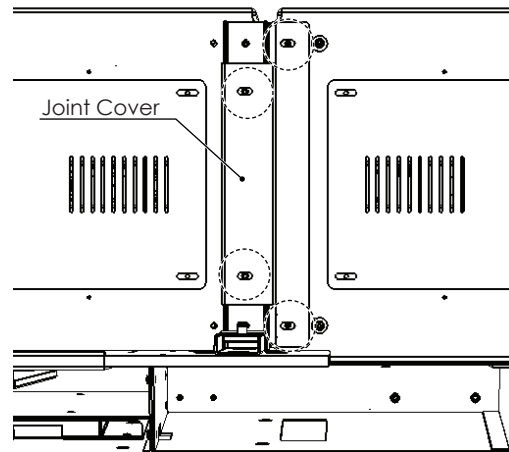

- 2 Applying the Upright Cover. Offer the UPRIGHT COVER BKT to both positions shown and secure using (4) M4x12 Hex Machine Screws. Take care not to trap any wires when fixing into position.

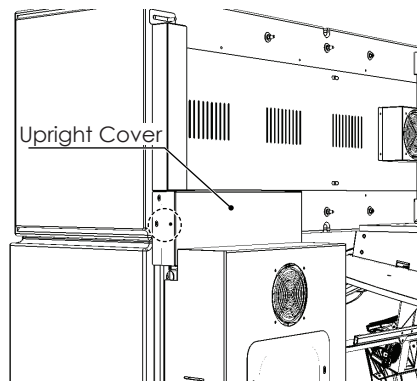
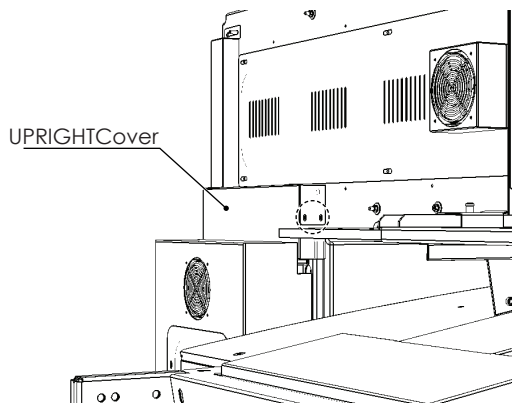

6-11 APPLYING POWER

STOP IMPORTANT

Each cabinet has its own dedicated mains power input. Only use the power leads (including extension power leads) supplied with this machine. **DO NOT** connect more than 2 units in any one extension power lead. Using power leads or extension cables not supplied with this product may cause an overload situation resulting in overheating, power failure or possibly a fire hazard.

WARNING

- Use the power supply equipped with an earth leakage breaker. Use of power supply without such a breaker could result in fire if there is a current leakage.
- Do not expose the power cord or ground wire. If these are exposed, customers could stumble over them, for instance, and easily damage them. Additionally, if these lines are damaged, there could be a risk of electrical shock or short circuit. Set these lines at locations where they will not interfere with customer traffic, or attach covers to them.
- After laying out the power cord on the floor, be sure to always protect it. If the power cord is left exposed, it can easily be damaged, resulting in electrical shock.
- This product must only be used within the countries that it has been designed for. If the information within this section does not appear to match your electrical requirements then please contact the offices where purchased before applying power.

WARNING

- The ride (seat) will move during the initialization operation. It is dangerous for people to be near the cabinet. One person should carry out initialization-related operations or the initialization operation should be started after carefully confirming that nobody is near the cabinet.
- Proceed with checks and tasks as indicated in these instructions. If instructions are not followed, or if tasks and/or checks are neglected, an electric shock or other very serious accident, even fatal accident, can occur. Also, customers could be injured while operating the product.
- For safe operation, inspect and check the operation of each part of the product when turning on the power. If any defects are found, deal with them immediately. Never operate the product with defects still present.

STOP IMPORTANT

After starting the initialization operation, wait until the ride stops and the advertising screen is displayed or until an error screen is displayed due to the detection of an error. If switches, etc. are inadvertently operated, faults or parts damage may occur.

- 1** Reinspect the assembly work, paying special attention to the points below. Finally, check that there are no persons near the ride. Have all the adjusters been properly grounded, and are no casters contacting the floor surface? Have all power cable terminal blocks been fastened correctly? Has the cover been attached to the terminal block? Have all fastening bolts and screws been tightened? Have any foreign objects been placed near the ride, or have any tools or spare screws, etc. been left on or in the product? Have any foreign objects been placed near the steering wheel?
- 2** Turn the main switch on the front of the cockpit ON. This sends power throughout the product. Following the order below, output locations will activate. 1) Billboard LED lights. 2) WINDOWS/SEGA logo is displayed on LCD screen. 3) Steering Wheel calibrates - moves fully left/right then returns to the centre position. 4) Seat moves to one side then returns to the centre position. 5) Inter-cabinet communication check (in case of communication connection setting). 6) The Game loading Screen appears on screen. 7) Game attract sequence begins
- 3** If, after the initialization operation ends, the steering wheel is not at its center position (facing straight ahead) or the ride stops at a tilted position, for example, reengage the power and conduct the initialization operation again. If the problem is not corrected after repeating the initialization, there is most likely a fault in the volume settings. Enter Test Mode, and check the settings. (See service manual.) For this product, the following data and settings are still saved even if the power is turned off. Coin numbers represented in fractions (number of coins deposited that are not enough for one credit) and bonus adder count data are not saved. - Number of credits - Ranking data - Test Mode settings (coin/credit settings, difficulty level, etc.)

There are (6) AC units. One of which is attached to each of the four cabinets and the other to the Marquee upright. These are the main components.

- Main switch
- Inlet for power cable connection
- Network (RJ45) for communication play.
- Fuses and fuse holder

1 Confirm that the main switch is at OFF.

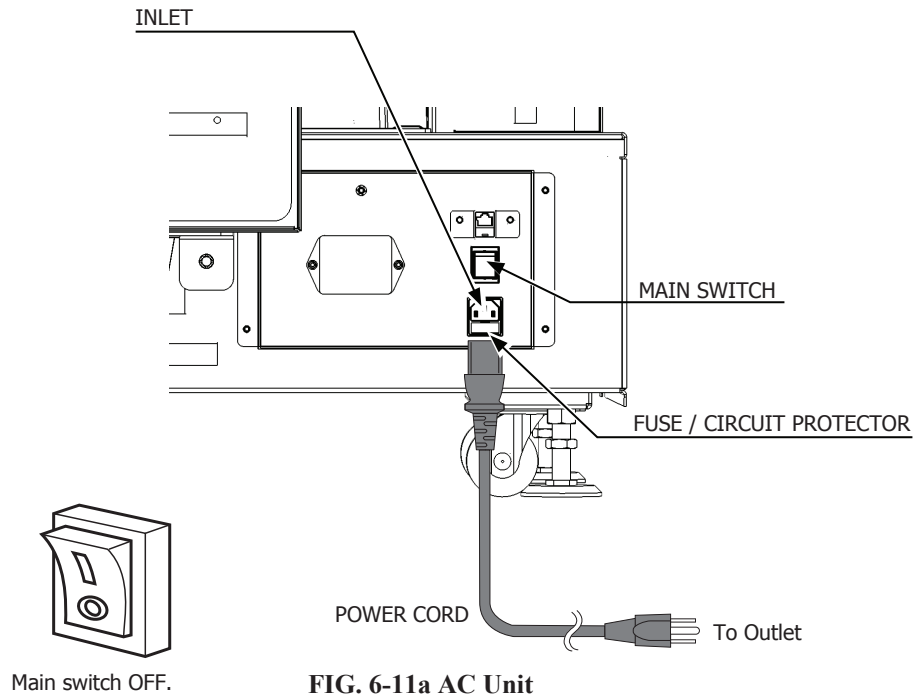

FIG. 6-11a AC Unit

2 Fully insert the power cord connector on the side opposite the power plug into the AC unit inlet.

3 The power cord is laid out indoors. Protect the power cord by attaching wire cover to it. If ground will be established with a ground wire made available separately, lay out the ground wire indoors and have it protected. <For Taiwan>

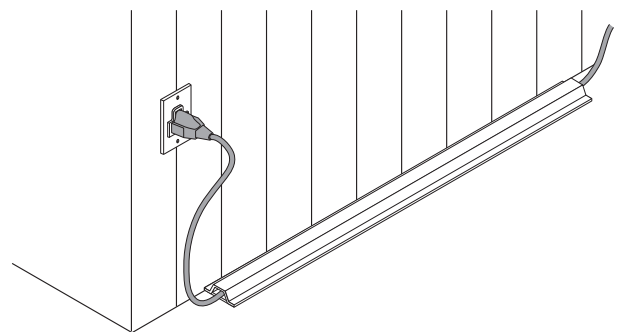
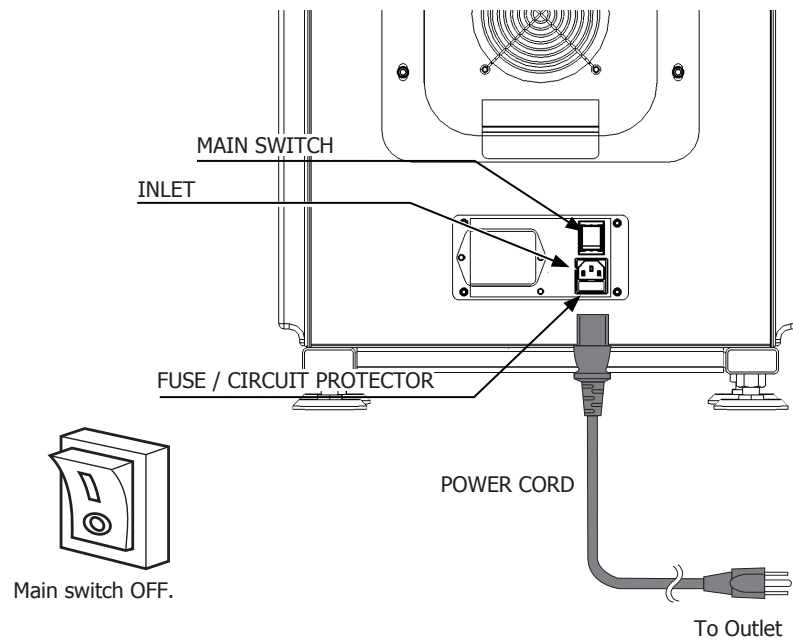
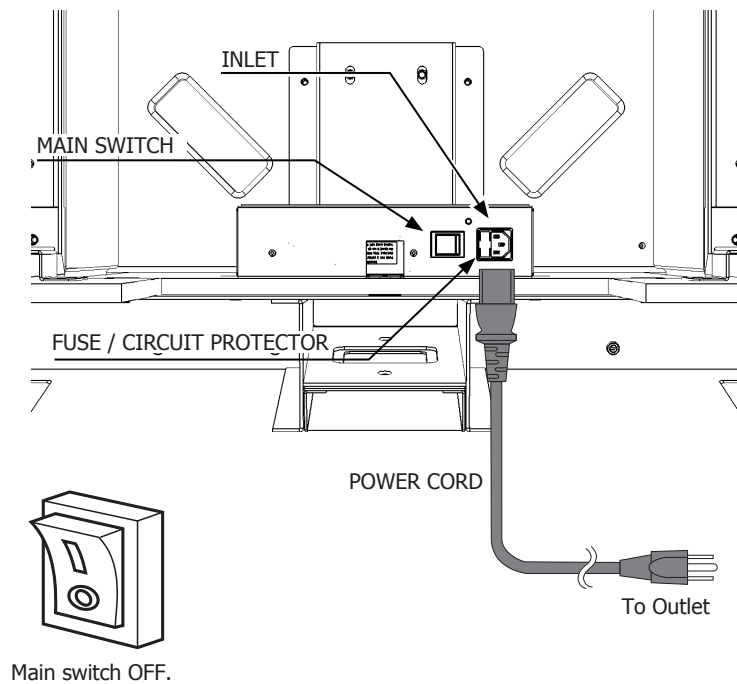

FIG. 6-11b

- 4** The fifth AC Unit is located at the rear of the L/H upright of the Marquee. Again, fully insert the power cord connector on the side opposite the power plug into the AC unit inlet.



- 5** Finally, insert the 5m Power Cable (supplied) into the AC unit located within the Top Center of the Marquee. This powers the (2) 42" displays.



- 6** Once all power cables have been connected into the relevant AC Units. Connect the 3 pin UK mains plugs into the (3) extension leads provided.

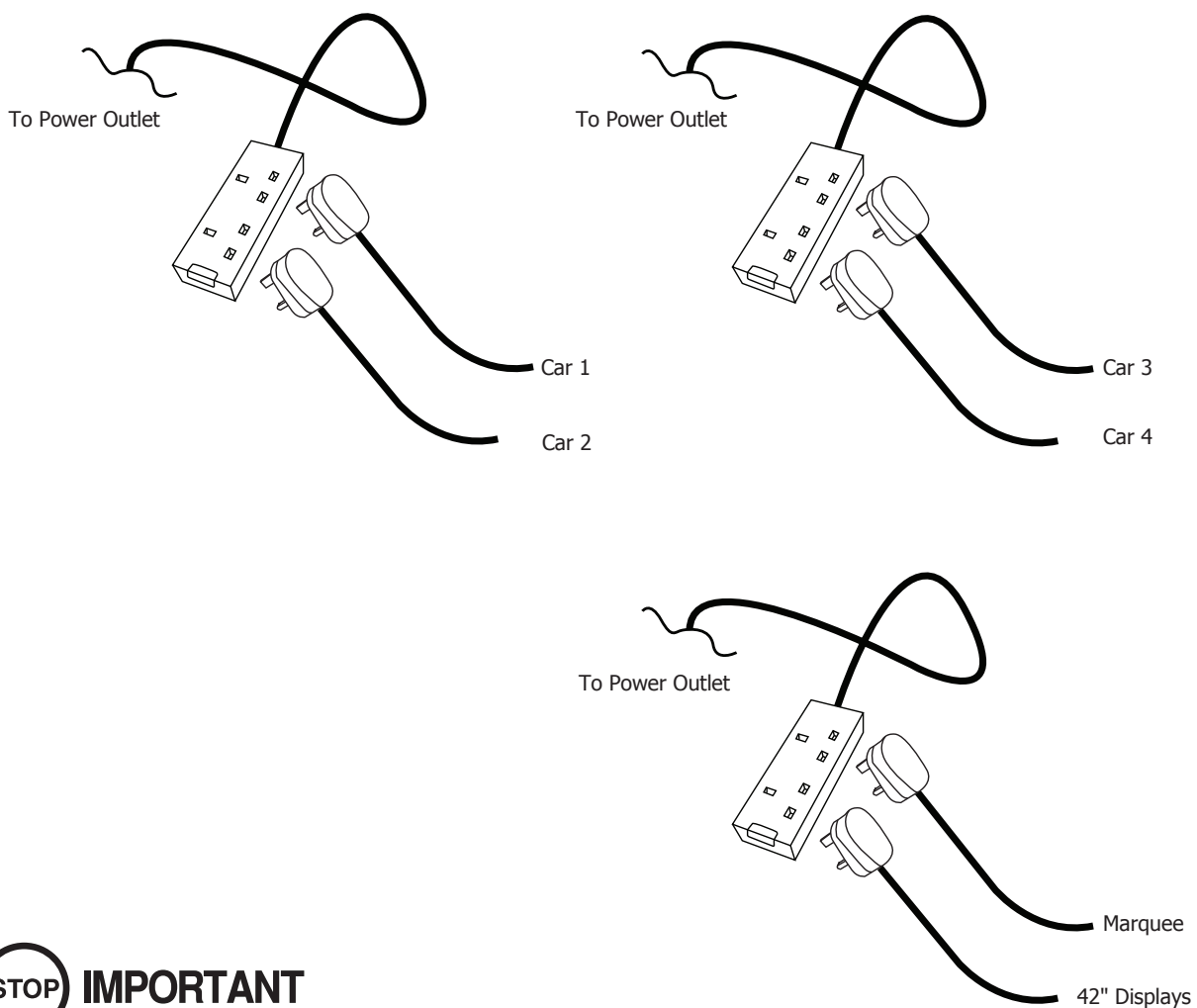

STOP **IMPORTANT**

Each cabinet has its own dedicated mains power input. Only use the power leads (including extension power leads) supplied with this machine. **DO NOT** connect more than 2 units in any one extension power lead. Using power leads or extension cables not supplied with this product may cause an overload situation resulting in overheating, power failure or possibly fire hazard.

6-12 CONFIRMATION OF INSTALLATION

Use test mode to confirm that assembly is proper, and that the CPU, connecting boards, and input/output devices are normal.

Perform the following tests in test mode.

For tests (1) to (4), refer to the TEST AND DISPLAY DATA within this Manual. For tests (1) to (3), see [9-2-1 Game Test Mode].

1 Input Test

When “INPUT TEST” has been selected on the game test mode menu, the screen for testing input device appears. Test operate the input device by pressing each switch. If the display on the side of each input device changes to “ON” and numerical values change smoothly in accordance with each operation, the input device and its wiring connections are normal. (See 9-3a.)



FIG. 6-12a INPUT TEST Screen

2 Output Test

When “OUTPUT TEST” has been selected on the game test mode menu, the screen for testing lamps and other output devices appears.

If each output device operates properly, the output device and its wiring connections are normal. (See 9-3b.)



FIG. 6-12b OUTPUT TEST Screen

3 Calibration

Confirm that the operability of control unit do not present any hindrances to play. Calibration is adjusted when the product is shipped from the factory but it might need to be adjusted again because of vibrations during transport, etc.

If such things as operability are not satisfactory, select “CALIBRATION” on the game test mode menu and check and adjust settings. (See 9-2.)

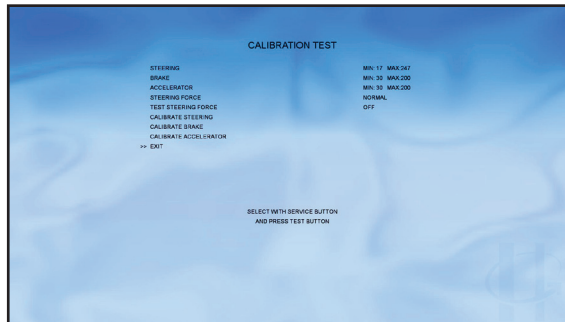

FIG. 6-12c GUN CALIBRATION Screen

4 Seat Motion

Confirm that the operability of seat motion does not present any hindrances to play. Calibration is adjusted when the product is shipped from the factory but it might need to be adjusted again because of vibrations during transport, etc.

If such things as operability are not satisfactory, select “CALIBRATION” on the game test mode menu and check and adjust settings. (See 9-2.)

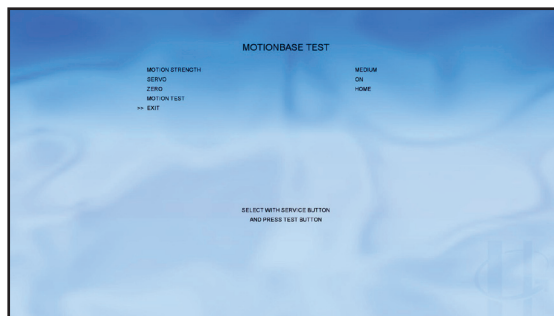

FIG. 6-12d SEAT CALIBRATION Screen

Conduct the aforesaid tests when performing routine tests each month.

7 PRECAUTIONS WHEN MOVING

⚠ WARNING

- As used in these instructions, the term “moving” refers to moving of the product within the same building, store or facility. These instructions do not cover moving between different buildings, areas, stores or facilities, since diverse factors are involved, not only packaging but also loading onto transport vehicles, and securing the product in place during transport. To transport the product to a different building or store, contact the vendor where the product was purchased or the office indicated in these instructions. Or request that moving be done for you. This product is made up of parts that are of large size and heavy weight. Unless work is entrusted to someone with expertise in packaging and transport of such parts, a serious accident might occur.
- Even when the product is to be moved within the same building, store or facility, contact the point of purchase or the office indicated in these instructions if there will be level differences or narrow or low level entrances while moving. Or request that moving be done for you. Never disassemble the product in any way not covered in these instructions. Otherwise there could be a fire, electric shock and/or short circuit.
- Always disconnect the power cable before moving the product. If it is moved with the power cable connected, the cable could be damaged, causing fire or electric shock.
- A qualified electrician is required for moving product parts within a store and for changing indoor wiring. Do not have work performed by anyone who is not qualified. Otherwise there could be electric shock.
- Have work performed by site maintenance personnel or other qualified individuals. Do not allow people without proper knowledge and technical expertise to work on the product. Otherwise there could be an electric shock or other serious accident. Also, customers could be injured while operating the product.
- Do not move this product while it is still assembled. Always take off the coin chute tower, the rear fence, and the step before moving it. Moving it while assembled could lead to damaged joints and mounting components which could in turn result in electrocution, short circuits or fire.
- Because it is structurally difficult for exterior lighting to enter the cabinet, have auxiliary lighting available. Working within a dark environment can lead to accidents. • For instructions on separation and disassembly of the cabinet, refer to Chapter 6 of this manual. Failure to follow the instructions given by this manual leaves a high risk of accidents such as electric shock occurring.
- Proceed with checks and tasks as indicated in these instructions. If instructions are not followed, or if tasks and/or checks are neglected, an electric shock or other very serious accident, even fatal accident, can occur. Also, customers could be injured while operating the product.
- Be careful not to damage wiring. Before separating parts that have wiring connections, disconnect the wiring connections, unravel wire bundles and undo fastenings. Only after that, remove fasteners (screws, nuts, etc.). If wiring becomes damaged, there could be an electric shock, short circuit or fire.

7-1 MOVING THE MACHINE

WARNING

- Always disconnect the power cable before moving the product. If it is moved with the power cable connected, the cable could be damaged, causing fire or electric shock.
- To move the unit over the floor, pull in the adjusters and have the casters contact the floor. While moving the unit, be careful that the casters do not roll over the power cord or the ground wire. If cord or wire is damaged, there could be electrical shocks and/or short circuits.
- When crossing a sloped or stepped area, disconnect the Display, Main Cabinet and Seat Cabinet. If you tilt them while connected together, the connection points may be damaged and personnel could be injured.
- When lifting the cabinet up steps, you must hold it by the designated handles or by the bottom surface. Lifting it by any other area may lead to damage or disfiguration to that part or surrounding parts due to the weight of the cabinet and could also lead to injury of personnel.
- When tilting the cabinet to move it across a sloped or stepped area, always use at least two people. Attempting such an operation alone can lead to accident or injury.

CAUTION

- When moving the components do not push any of the plastic elements or shaped parts. Do not use them to pull the components along either. This may damage the parts or the surrounding parts and this could lead to accidents or injury.
- Do not use the Control Units in the Main Cabinet to push or pull the cabinet. This may damage or disfigure these parts and lead to malfunctions or injury.
- When moving the cabinet, be sure to push/pull each cabinet lengthways. Trying to move the cabinet any other way may cause the cabinet to topple over.

STOP IMPORTANT

- When moving the cabinet, do not hold, push or pull the Control Units. This may disfigure or damage them.
- If you need to move components through a narrow or low door and the only way to get the separated components through is to turn them on their side, or if a separation method other than those described in this manual is required, either make a request to the office listed in this document or the place of purchase to perform the operation or contact them regarding how to perform it. Carelessly turning the components onto their side or separating them in ways other than those depicted in this manual may lead to unrepairable damage.
- Do not press the LED screen. The screen can be easily damaged and cannot be repaired if it is, meaning complete replacement will be necessary.

⚠ CAUTION

- To work safely and precisely prepare a steady, safety stool or ladder to stand on. Climbing onto the cabinet or hanging down from it can lead to accidents.

STOP IMPORTANT

Everytime the machine is moved from its position, it is important that the perimeter safety sensors are checked for alignment.. Please refer to section 6.12 of this manual (Conformaiton of Installation)..

⚠ CAUTION

- The nature of this machine and the way in which is installed means that it is unable to be relocated easily.
- To relocate this machine a full disassembly is required. Follow the instructions on section 6 of this manual and carry out its procedures in reverse order.
- Do not attempt to move this product with the Marquee attached or a cabinet linked to another. Doing so may result in damage to components or injury.

8 GAME DESCRIPTION

Showdown is the latest ground-breaking racing game from legendary arcade machine manufacturer Sega in collaboration with racing software specialists Codemasters, the team behind 2010's hugely successful GRID arcade racing game.

Showdown delivers thrills and full contact racing in every event, each an electrifying festival of energy, speed and destruction that demands repeat play.

Players will fully commit on every corner and overtake as they take on spectacular circuits set across the world. Showdown's tracks are littered with obstacles, pinch points, multiple-routes and ramps to deliver action-packed, white-knuckle action in each and every race. Players become fully immersed in the action with the game's stunning graphics. An all-new handling system makes the game both accessible and rewarding for the player as they dive into a new world of motorised mayhem bursting with speed, style and destruction.



8-1 BONUS CODE

Showdown features an exciting 'unlock' mechanic that is awarded to the player after every game. The reward is dependent on the event raced and the result, which means that even if the player doesn't finish in 1st place they still receive a bonus code for finishing.

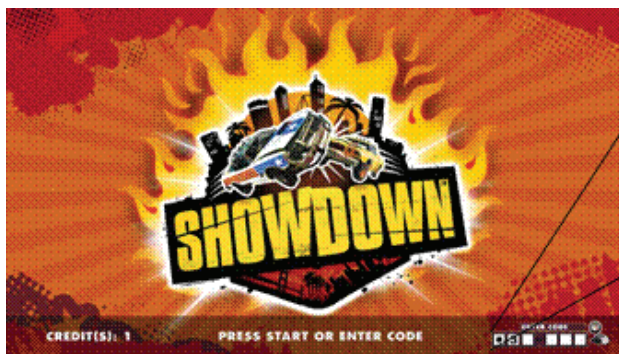

When the game is in credit the player has the option to enter a code using the keypad, located to the right of the steering wheel, or to press the start button.

Entering a valid code will unlock content that the player can select in various pre-race menus.

The code entry section in the bottom right corner of the screen will change to show the code has been accepted.

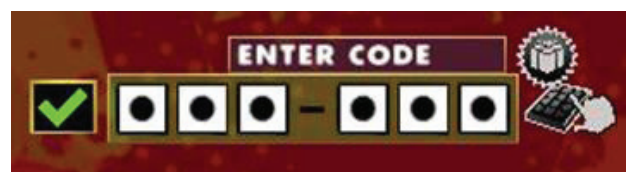

Any content that has been unlocked will appear first in the menu selection screens, so that it can be easily found. It will also display the 'Bonus Item' text and logo in the top right hand corner.



Any content previously unlocked or ordinarily available will precede the bonus items.

An incorrect code can be entered a maximum of 3 times, at this point the player will need to press the start button to start their game. A code can be entered again after the game is over.

After finishing an event, the player's bonus code will be displayed on screen and remain there for 10 seconds. If the player inserts another credit within this time, or already has a credit available, the game will automatically apply this bonus code to the game. After 10 seconds the code will disappear from the screen, any credits inserted after this will require a bonus code to be entered or to play the game without a code.



Showdown's unique composite 'unlock' system allows players to keep the bonus items they have collected and then use them at any location encouraging repeat play. When a player uses a code and then unlocks a new feature they are given a new code with the new item added to their previous collection.

Bonus codes are awarded by the game, via Segascores.com and also distributed via Sega Amusements' social media.

8-2 GAME SELECTION

WHEN THE MACHINE IS IN CREDIT AND THE START BUTTON IS PRESSED, THE FOLLOWING SCREEN IS DISPLAYED, INDICATING THE GAME PLAY AVAILABLE.

When a cabinet is not linked up to any other cabinets, once the player presses the Start button, they will be taken straight to a Single Player game where they are given the option between CHALLENGE and TOUR.

The first action for the player is to select whether to enter into a Multiplayer or Single Player game. Turning the Steering Wheel left and right will highlight the option and pressing the Accelerator pedal, or the start button, will confirm the player's selection.

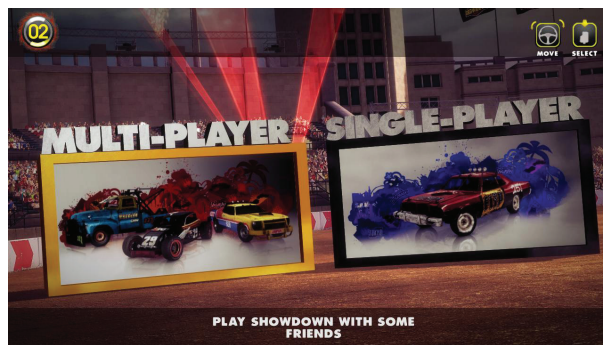

During this selection process, a countdown is displayed in the top left hand corner of the screen. If the player does not make a selection within this time, the highlighted option will be selected.

If the player has entered into a Single Player game, they will have the choice of two game modes – Challenge or Tour.

Again, turning the steering Wheel left and right will highlight the option and pressing the Accelerator pedal, or the start button, will confirm the player's choice.

During this selection process, a countdown is displayed in the top left hand corner of the screen. If the player does not make a selection within this time, the highlighted option will be selected.

Name Entry

Before the player can pick an event to play, they must first enter a 3 letter name to represent them in their chosen event.

If the player fails to enter their initials in the allotted time, or enters a forbidden combination they will be assigned 'PLA'.

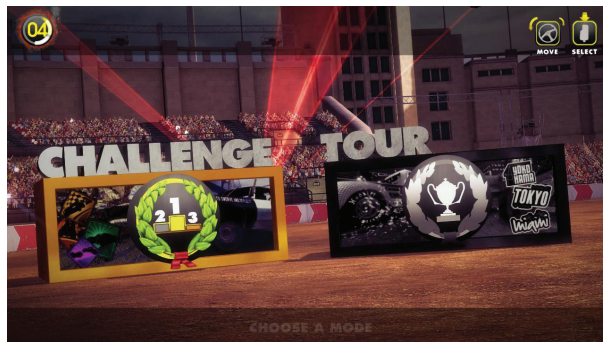

PLEASE NOTE The 3 letters are used to authentic a players high score on the Sega Scores leader boards when used with the QR Code provided on the race results screen. Please visit www.segascores.com for more details.

Turning the Steering Wheel left and right will highlight the option and pressing the Accelerator pedal, or the start button, will confirm the player's choice.

During this selection process, a countdown is displayed in the top left hand corner of the screen.

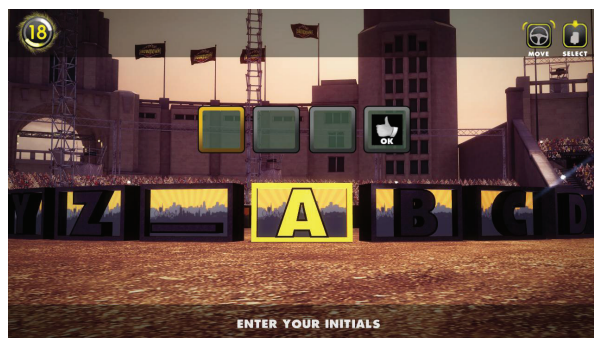

8-3 CHALLENGE

Challenge mode can be played in either Single Player or Multiplayer format. This mode features four types of events each with different rules and requirements in order for the player to achieve 1st place. All events have eight racers. Any cars not controlled by human players will be AI controlled.

Turning the Steering Wheel left and right will highlight the option and pressing the Accelerator pedal, or the start button will, confirm the player's choice.

During this selection process, a countdown is displayed in the top left hand corner of the screen. If the player does not make a selection within this time, the highlighted option will be selected.

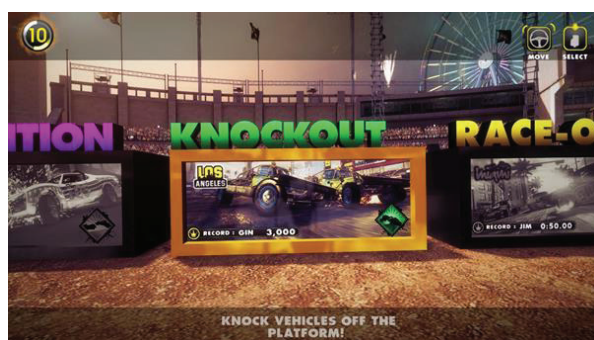

DEMOLITION

A closed arena map where the aim is to take out opponents by smashing, bashing and shunting them to oblivion. Points are awarded for hitting opponents. The harder you hit them, the more points you earn. Maximum points are awarded for depleting the health of an opponent. The player with the most points at the end of timer wins.

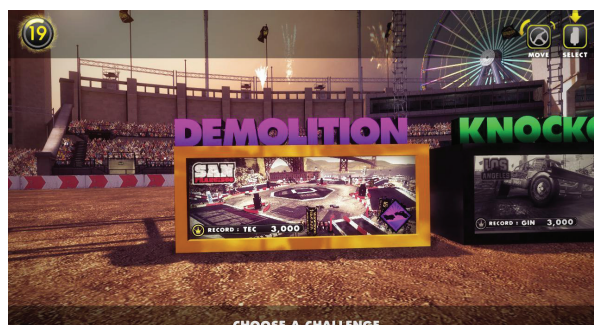

KNOCKOUT

Push pedal to metal and drive it like you stole it as you knock out opponents from the top of the platform, and try to stay on top yourself. Use boost to deliver crunching T-Bone crashes or dash out the way of incoming hits. Points are awarded for knocking opponents off the podium as well as causing damage. Maximum points are awarded for knocking opponents off the podium. The player with the most points at the end of timer wins.

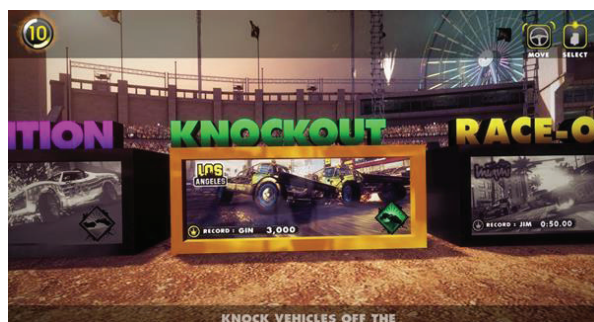

RACE-OFF

A no holds barred, wild racing event where it's a fight to the finish line by any means necessary. Show your opponents who is the true king of the road by smashing them off it as you sprint for the chequered flag. The first player to complete all laps wins.

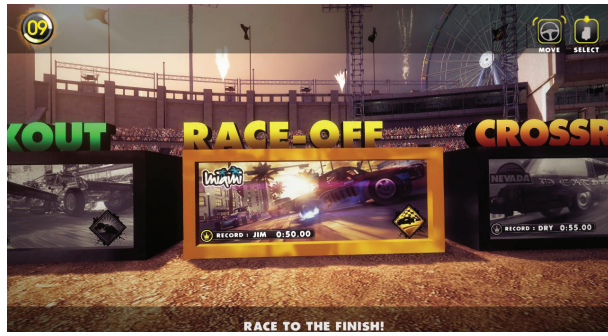

CROSSROADS

Race on a classic figure of eight circuit where it's full-on carnage at the track's intersection points. The first player to complete all laps wins.



TOUR

Tour is a single player only mode against 7 AI opponents over 3 of the Challenge events.

Turning the Steering Wheel left and right will highlight the option and pressing the Accelerator pedal, or the start button, will confirm the player's choice.

During this selection process, a countdown is displayed in the top left hand corner of the screen. If the player does not make a selection within this time, the highlighted option will be selected.

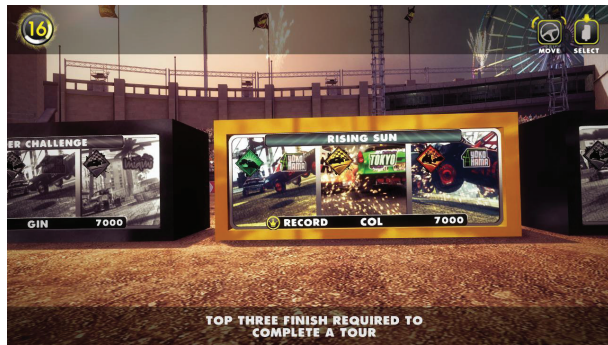

To unlock the next event the player must place in the top 3 positions. After each event the player is awarded points, the points across all 3 events are combined. The player with the highest score will be crowned the victor!

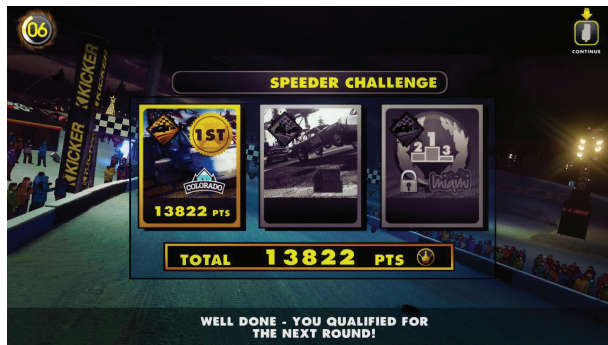

If a player fails to complete an event they will have the option of inserting a credit and continuing from the start of the same event.



8-4 MULTIPLAYER

If the player selects Multiplayer they will be taken to a waiting lobby. This gives the chance for other players to join in. A maximum 4 human players in total can race in any event, the rest are AI controlled.



Any cabinets connected in the same network will be shown a challenge available screen.

After inserting a credit, the challenging players are able to enter their bonus code, or just press the start button to join.

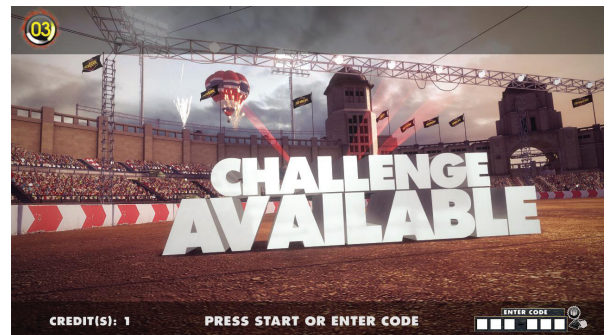

If other players join the multiplayer game, when the timer runs out, all players will then have the chance to enter their name.

Please see NAME ENTRY above for more information.

If other players do not join the multiplayer game then the player that initiated the multiplayer game will instead play a single player game.

Challenge mode is the only option available for multiplayer games. Although some event locations may be different to the single player challenge events, the event types are the same.

These are Crossroads, Demolition, Knockout and Race-Off.

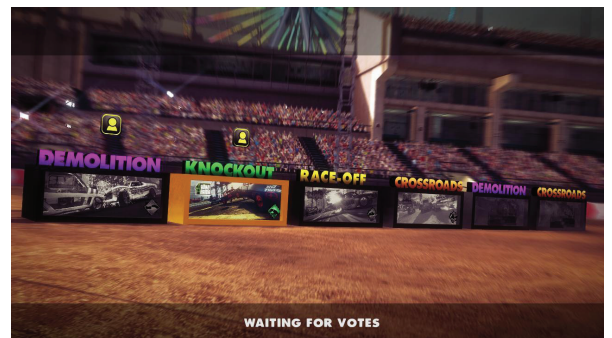

In a multiplayer game, event selection is decided upon by a voting system. Each player within the game will be given their choice of event to select.

Once all players have selected an event, whichever event has the most votes will be played.

In the case of a tie, the event will be selected at random.

The players are then taken through the default Car and Livery select screens.

If a player has selected both their car and livery whilst others are still making their selections, the player will be held on a Waiting For Other Players screen.

When all players have made their selection, the event will begin.



8-5 CARS

The next choice for the player is to select which car to drive. There are ten car classes featuring twenty cars - from muscle cars and pick-up trucks to sports cars and even a hearse! This means there is a ride to suit every driver's desire! Each has its own strengths, weaknesses and character, so players can choose their favourite, or conquer them all as they take on Showdown's different race events.

Turning the Steering Wheel left and right will highlight the option and pressing the Accelerator pedal, or the start button, will confirm the player's choice.

During this selection process, a countdown is displayed in the top left hand corner of the screen. If the player does not make a selection within this time, the highlighted option will be selected.

The four main classes available are:

- PICKUP
- SALOON
- SPECIAL
- TUNED

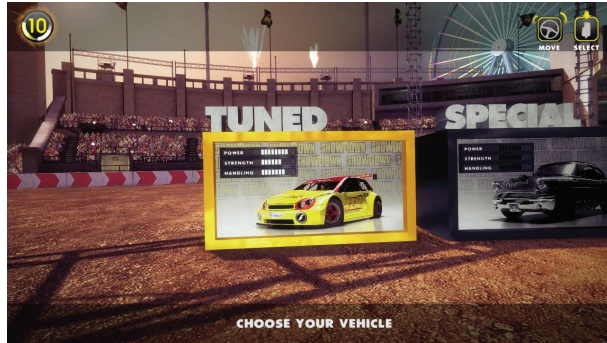

8-6 LIVERIES

After selecting the class of car the player can select a livery (paint job).

Turning the Steering Wheel left and right will highlight the option and pressing the Accelerator pedal, or the start button, will confirm the player's choice.

During this selection process, a countdown is displayed in the top left hand corner of the screen. If the player does not make a selection within this time, the highlighted option will be selected.

The four main liveries available are:

- FLIP
- HANS
- NO FEAR
- SIMPSON

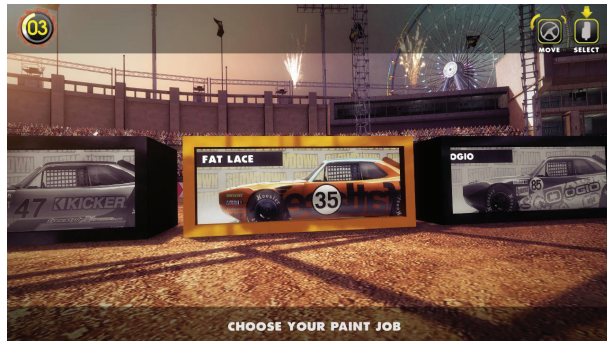

8-7 ON-SCREEN DISPLAY

Before the event begins, a brief video is played that shows the player an overview of the course and a hint box informing the player what they have to do.

After this introduction the countdown timer begins and at this point the game begins.

The On Screen Display will differ according to event type, however there are some details that appear in all game modes.

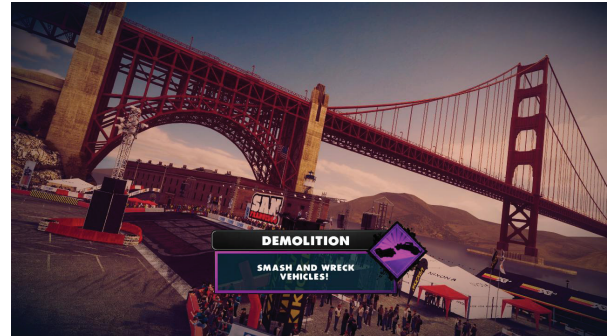

Demolition and Knockout

| | |
|---------------|------------------------------------------------------------------|
| Score | Total points awarded to the player |
| Location Icon | Displays the icon for the location of the event. |
| Time Left | Time remaining to complete the lap and extend the time. |
| Music Track | Shows the title and artist of the music track currently playing. |
| Position | Displays the player's position in the race. |
| Event Icon | Displays the icon for the event type. |



| | |
|------------------|----------------------------------------------------------------------------------------------------|
| Position Detail | Shows the player's position along with the positions of all other opponents and the current scores |
| Health and Boost | Shows the health of the car in green and boost available in blue. |

Race-Off and Crossroads

| | |
|---------------|------------------------------------------------------------------|
| Location Icon | Displays the icon for the location of the event. |
| Time Left | Time remaining to complete the lap and extend the time. |
| Lap Indicator | Displays which lap the player is currently on. |
| Lap Time | Current lap time. |
| Best Lap | Fastest lap time. |
| Music Track | Shows the title and artist of the music track currently playing. |



| | |
|---------------------|------------------------------------------------------------------------------|
| Leader Indicator | An crown icon above the car currently in 1st position |
| Player Indicator | An icon above any other human racer. |
| Position and Name | An icon that shows the AI or human's position and name/initials. |
| Health Bar | Displays the health remaining of the opponent car. |
| Proximity Indicator | Represents position of opponents approaching from the rear. |
| Position | Displays the player's position in the race. |
| Event Icon | Displays the icon for the event type. |
| Position Detail | Shows the player's position along with the positions of all other opponents. |
| Health and Boost | Shows the health of the car in green and boost available in blue. |

Drivers View – Camera Position

Showdown features two different in-game camera views that are cycled between when the VIEW CHANGE button is pressed.

BUMPER CAMERA



CHASE CAMERA



8-8 HIGH SCORE TABLES

High Score Tables

Every event has a high score table that records a player's performance, whether playing single player or multiplayer. The name entered pre event selection is used for the high score table.

Depending on the mode or event played, different information is recorded.

Demolition, Knockout and Tour

Rank

Name (3 characters)

Car

Score

Race-Off and Crossroads

Rank

Name (3 characters)

Car

Time

8-9 LISTS - CARS, LIVERIES, EVENTS, LOCATIONS & TOURS

| Cars | |
|----------|-----------|
| Standard | Bonus |
| Pickup | Coupe |
| Saloon | Cruiser |
| Special | Muscle |
| Tuned | Old-Timer |
| | Sport |
| | Truck |

| Liveries | |
|----------|-----------------|
| Standard | Bonus |
| Flip | Fat Lace |
| Hans | Hooker Header |
| No Fear | K&N Airfilters |
| Simpson | Kicker |
| | Ogio |
| | Skin Industries |

| Event Single Player | | Event Multiplayer | |
|---------------------|-------------|-------------------|-------------|
| Crossroads | | Crossroads | |
| Standard | Bonus | Standard | Bonus |
| Nevada | Los Angeles | Los Angeles | Nevada |
| Demolition | | Demolition | |
| Standard | | Standard | Bonus |
| San Francisco | | San Francisco | Los Angeles |
| Knockout | | Knockout | |
| Standard | | Standard | |
| Los Angeles | | Yokohama | |
| Race-Off | | Race-Off | |
| Standard | Bonus | Standard | |
| Miami | Colorado | Miami | |

| Tours | |
|-------------------|----------------------------------------------------------------------------|
| Tour Name | Events in tour |
| Bayside Tour | Race-Off – Tokyo, Demolition - San Francisco, Race-Off – Miami |
| Big Rumble | Demolition – San Francisco, Yokohama – Knockout, Demolition – Los Angeles |
| LA Baby | Crossroads - Los Angeles, Demolition - Los Angeles, Knockout – Los Angeles |
| Racers League | Race-Off – Miami, Race-Off – Tokyo, Race-Off – Colorado |
| Rising Sun | Knockout – Yokohama, Race Off - Tokyo, Crossroads – Yokohama |
| Speeder Challenge | Race-Off - Colorado, Crossroads - Yokohama, Race-Off – Miami |
| Bonus Tour Name | Events in tour |
| Bright Lights | Knockout – Los Angeles, Race-Off – Tokyo, Demolition – Los Angeles |
| Mega Mix Tour | Crossroads – Yokohama, Demolition - San Francisco, Race-Off – Colorado |

9 EXPLANATION OF TEST AND DATA DISPLAY

Perform tests and data checks periodically by manipulating the TEST Button and SERVICE Button in the cabinet. Follow the instructions in this chapter to conduct checks when the game machine is first installed, when money is being collected, or when the game machine does not operate properly.

Shown overleaf are the tests and screens to be used for different problems.

WARNING

- When installing 2 or more cabinets which are networked together. The GAME SETTINGS which are adjusted within the first cabinet are reflected throughout all cabinets within that network.

IMPORTANT

- When changing the game configuration within the TEST MODE, be sure to exit all screens in the correct manner by choosing exit. DO NOT turn the machine ON/OFF to resume game. Changes WILL NOT take effect unless the correct method is used.

9-1 SWITCH UNIT AND COIN METER

WARNING

Never touch places other than those specified. Touching places not specified can cause electric shock and short circuit accidents.

IMPORTANT

- Adjust the sound to the optimum volume, taking into consideration the environmental requirements of the installation location.
- Removing the Coin Meter circuitry renders the game inoperable.

9-1-1 SWITCH UNIT (U.S. TYPE)

Open the coin chute door, and the switch unit shown will appear.
The functioning of each SW is as follows:

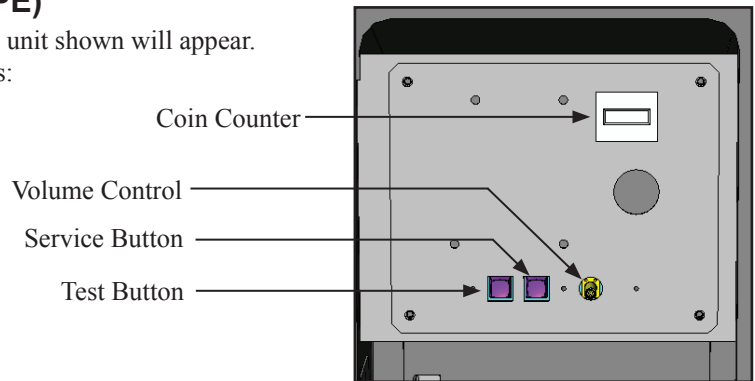

9-1-1 FIG. 01

| | |
|-------------------------------------|--------------------------------------------------------------------|
| TEST Button (TEST): | For the handling of the Test Button, refer to the following pages. |
| SERVICE Button (SERVICE): | Gives credits without registering on the coin meter. |
| Sound Volume Switch (SOUND VOLUME): | Adjust sound volume for all of the machines' speakers. |
| Coin Counter | Counts and displays coins in \$0.10 units. |

9-2 TEST MODE

STOP IMPORTANT

- The details of changes to Test Mode settings are saved when you exit from Test Mode by selecting EXIT from the system test mode menu. Be careful because if the power is turned off before that point, changes to the settings will be lost.
- Entering the Test Mode clears fractional number of coins less than one credit and bonus adder data.
- Use with the specified settings. If settings other than those specified are used, inappropriate operations or malfunction may occur.

9-2-1 TEST MENU

The following options are available from the System Test Menu.



9-2 FIG. 01

Use the SERVICE button to move the cursor to the desired test item. Press the TEST button to enter the selected item.

| | |
|---------------------|-----------------------------------------------------------|
| SYSTEM INFORMATION: | General information on Software & Hardware. |
| INPUT TEST: | Test routine for Input Peripherals. |
| OUTPUT TEST: | Test routine for Output Peripherals. |
| MOTION BASE TEST: | Test routine for the Seat Motion System. |
| COIN SETTINGS: | Test routine for Coin Handling. |
| SOUND SETTINGS: | Test routine for Audio Outputs. |
| SCREEN TEST: | Test routine for the Display Screen. |
| NETWORK TEST: | Test routine for the Ethernet link. |
| CALIBRATION TEST: | Calibration routine for Input Peripherals. |
| BOOKKEEPING: | System meters and bookkeeping. |
| CLOCK SETTINGS: | System Clock setting. |
| GAME SETTINGS: | Change the settings within the game (number of laps etc). |
| EXIT: | Exit the System Test Menu back to the game. |

9-2-2 SYSTEM INFORMATION

Select 'System Information' from the Test Menu to display the System Information menu.

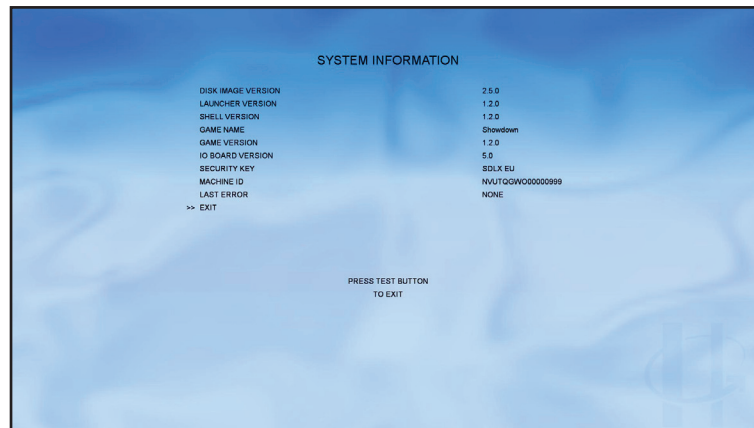

9-2 FIG. 02

Select 'SYSTEM INFORMATION' from the Test Menu to display the System Information menu.

The System Information Test lists revision numbers and names of currently installed system components.

| | |
|--------------------|--------------------------------------------------------------------------------------------------------------------------------------------------------------------------------------------------------------------------------------------------------------------------------------------|
| DISK IMAGE VERSION | Version number for the master hard disk image |
| LAUNCHER VERSION | Version number of System Launcher program |
| SHELL VERSION | Version number of Shell program |
| GAME NAME | Name of currently installed game |
| GAME VERSION | Version number of currently installed game |
| IO BOARD VERSION | Version number of IO board in use |
| SECURITY KEY | Type of security key in use |
| MACHINE ID | Unique number of the cabinet used to register on Sega Scores website (please visit www.segascores.com for instructions) |
| LAST ERROR | Shows the time and date and value of the last numeric error code received from the motion base system. This value is cleared only when system book keeping is cleared. If you receive an error please note down the Error code, Machine Serial Number and contact the SEGA Service Centre. |

Move the cursor to EXIT and press the TEST button to return to the Test Menu screen.

9-2-3 INPUT TEST MODE

STOP IMPORTANT

If an error is displayed during the input test, look up the error code within this manual and try to determine the cause of the error, and take the appropriate corrective measures. If problems continue, contact your local SEGA office for further advise.

Select 'Input Test' from the Test Menu to display the Input Test menu.



9-2 FIG. 03

This menu is used to test the System Inputs such as Steering, Pedals and Buttons. To implement the test, press each device that is listed and check the results on screen.

| | |
|----------------|-------------------------------|
| STEERING | 0000 to 0255 |
| BRAKE | 0000 to 0255 |
| ACCELERATOR | 0000 to 0255 |
| START BUTTON | ON/OFF |
| VIEW BUTTON | ON/OFF |
| BOOST BUTTON | ON/OFF |
| MUSIC SELECT | ON/OFF |
| MOTION STOP | ON/OFF |
| COIN INPUT | ON/OFF |
| OPTO SENSORS | OFF/LEFT/RIGHT/REAR |
| SEATBELT | (IF FITTED) ON/OFF/NOT FITTED |
| KEYPAD | 0-9, *, # |
| TEST BUTTON | ON/OFF |
| SERVICE BUTTON | ON/OFF |

Press the TEST and SERVICE button together to return to the Test Menu screen.

9-2-4 OUTPUT TEST



9-2 FIG. 04

Select 'OUTPUT TEST' from the Game Test Menu to display the Output Test Menu.

This test is used to check all configured outputs from the IO board.

Use the SERVICE button to move the cursor to the desired test item.

Press the TEST button to test the selected item.

| | |
|-----------------------|--------------------------------------|
| START LAMP | ON= Lamp ON / OFF=Lamp OFF |
| MOTION STOP LAMP | ON= Lamp ON / OFF=Lamp OFF |
| RACE LEADER | ON= Lamp ON / OFF=Lamp OFF |
| KEYPAD EDGE LAMP | ON= Lamp ON / OFF=Lamp OFF |
| MOTION STOP EDGE LAMP | ON= Lamp ON / OFF=Lamp OFF |
| DOWNLIGHTS | OFF/RED/GREEN/BLUE |
| MOULDING | OFF/RED/GREEN/BLUE |
| FOOTWELL | OFF/RED/GREEN/BLUE |
| BOOST LAMP | OFF/RED/GREEN/BLUE |
| REAR BASE LIGHTING | OFF/RED/GREEN/BLUE |
| DASHBOARD | OFF/OIL/HAZZARD/INDICATOR/HANDBRAKE |
| BRAKELIGHTS | OFF/RED/GREEN/BLUE/ATTRACT/BOOST |
| GAUGES | OFF/VOLTMETER/SPEEDOMETER/FUEL GAUGE |
| LED RED | Change optional lighting to RED |
| LED BLUE | Change optional lighting to BLUE |
| LED GREEN | Change optional lighting to GREEN |

Please note that turning on more than LED will change the colour accordingly:

| | |
|---------------------|-----------------------|
| RED and GREEN | Panel will be YELLOW |
| RED and BLUE | Panel will be MAGENTA |
| GREEN and BLUE | Panel will be CYAN |
| RED, GREEN and BLUE | Panel will be WHITE |

EXIT This will turn all lamps and LED's off

Move the cursor to EXIT and press the TEST button to return to the Test Menu screen.

9-2-5 MOTION BASE TEST

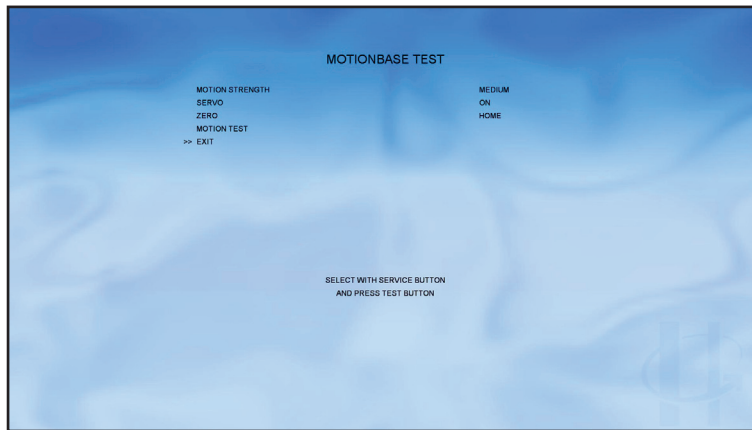

9-2 FIG. 05

Select 'MOTION TEST' from the Game Test Menu to display the MOTION TEST Menu.

This test is used to check the features and operation of the Motion Base System.

Use the SERVICE button to move the cursor to the desired test item.
Press the TEST button to test the selected item.

Motion Strength

- Values: OFF/WEAK/MEDIUM/STRONG
- Default Value =MEDIUM

Allows the selection of the intensity of the motion system. OFF disables motion in Game

Servo

- Values: ON/OFF

Enables or disables the motion base servo. (Default =ON) When the servo is turned off the seat may be manually positioned as the servo is not energised.

Zero

When enabled will carry out the calibration of the motion base. The seat will move to the left most position and return to centre (HOME position)

Motion Test

When enabled will run a gentle motion simulation moving the seat left and right. See screenshot below of motion test running. Pressing the Test button will stop this motion

EXIT

Upon exiting this menu the seat motion system will recalibrate

Move the cursor to EXIT and press the TEST button to return to the Test Menu screen.

9-2-6 COIN TEST

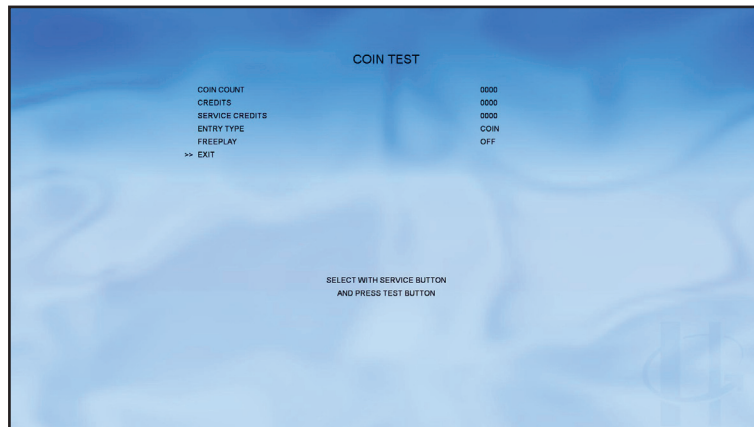

9-2 FIG. 06

Select 'Coin Settings' from the Test Menu to display the Coin Settings Menu.

Use the SERVICE button to move the cursor to the desired test item.
Press the TEST button to change the selected item.

This test displays the accumulative coins and credits values. Freeplay can be turned on/off.

| | |
|-----------------|-----------------------------------------------------|
| COIN COUNT | Coin Count value from IO board (cannot reset) |
| CREDITS | Total number of Coin credits added to the system |
| SERVICE CREDITS | Total number of Service Credits added to the system |

Use the SERVICE button to move the cursor to the desired test item.
Press the TEST button to test the selected item.

| | |
|------------|---------------------------------------------------------------------------------------------------------------------------------------------------------------|
| ENTRY TYPE | COIN or CARD SWIPE |
| FREEPLAY | ON – Freeplay is on, pressing the Start button during attract sequence will issue a credit. OFF – Credits can only be added using coins or service button. |

EXIT This will save any changes to Freeplay to this cabinet only

9-2-7 SOUND TEST

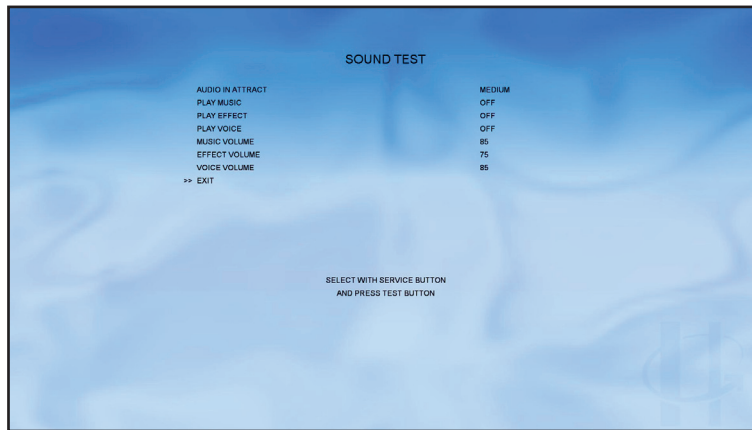

9-2 FIG. 07

Select 'Sound Settings' from the Test Menu to display the Sound Settings Menu.

This test is used to set the audio levels for the game and test the function of the speakers.

This test is used to test the function of the speakers and set audio levels for the Game.

Use the SERVICE button to move the cursor to the desired test item.

Press the TEST button to test the selected item.

| | |
|------------------|--------------------------------------------------------------------------------------|
| AUDIO IN ATTRACT | OFF – No music played during attract Other options are: LOW, MEDIUM and HIGH |
| PLAY MUSIC | ON - Test the sound level of the music in game OFF – Turn the test music off |
| PLAY EFFECT | ON – Test the sound level of effects in game OFF – Turn the test music off |
| PLAY VOICE | ON – Test the sound level of voice in game OFF – Turn the test music off |
| MUSIC VOLUME | Change the volume of music in game 0-100 (increments of 10) Default value is 30 |
| EFFECTS VOLUME | Change the volume of effects in game 0-100 (increments of 10) Default value is 30 |
| VOICE VOLUME | Change the volume of voice in game 0-100 (increments of 10) Default value is 30 |
| EXIT | This will save any changes to game volumes |

Move the cursor to EXIT and press the TEST button to return to the Test Menu screen.

9-2-8 SCREEN TEST

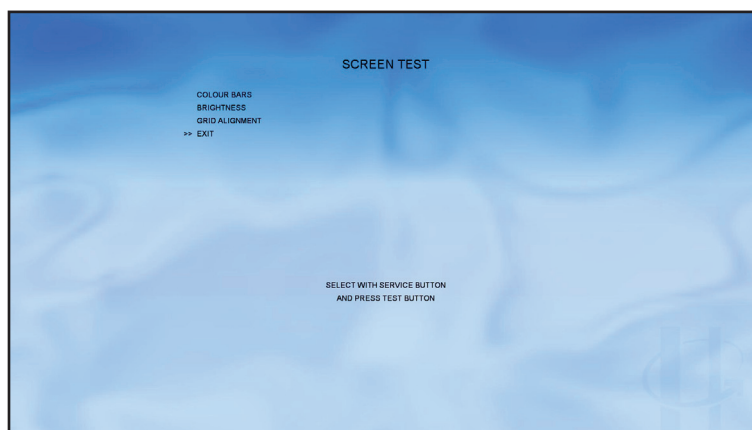

9-2 FIG. 08

Select 'Screen Test' from the Test Menu screen to display the Screen Test menu.

Use the SERVICE button to move the cursor to the desired test item.
Press the TEST button to enter the selected item.

COLOUR BARS – Selecting this test will display the following:

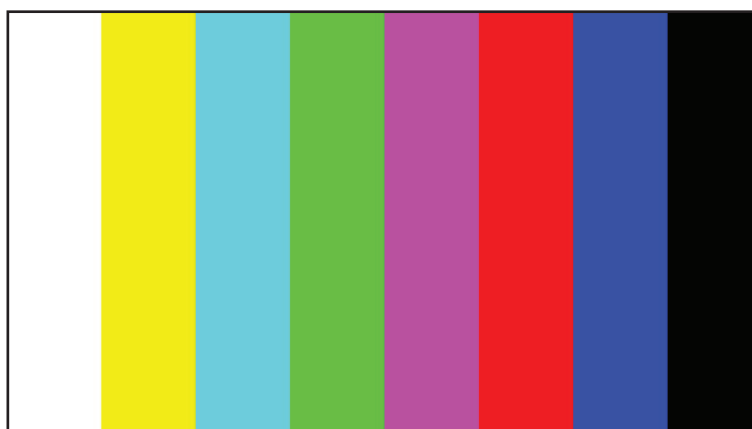

9-2 FIG. 09

GRID ALIGNMENT – Selecting this test will display the following:

Move the cursor to EXIT and press the TEST button to return to the Test Menu screen.

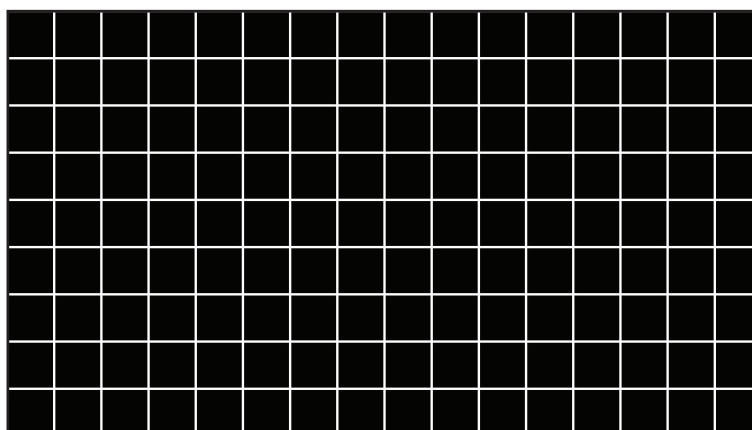

9-2 FIG. 10

9-2-9 NETWORK TEST

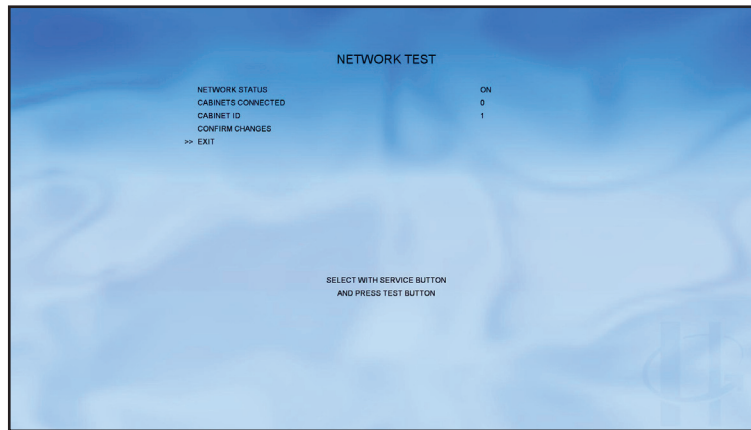

9-2 FIG. 11

Select 'Network Test' from the Test Menu to display the Network Test menu.

This test is used to check the Network link between cabinets (if connected).

Use the SERVICE button to move the cursor to the desired test item.

Press the TEST button to enter the selected item.

| | |
|---------------------|----------------------------------------------------------------------------------------------------------------------------------------------------------------------------------------------------------------------------------------------------------|
| NETWORK STATUS: | ON if network hardware is OK. FAILED if network hardware is faulty. |
| CABINETS CONNECTED: | The number of cabinets connected EXCLUDING the current one. (So if two cabinets are linked, this will show 1 cabinet connected). |
| CABINET ID: | ID Cabinet from 1 to 6. If this value is changed, the user must use CONFIRM CHANGES below in order to confirm the new ID of the cabinet. |
| CONFIRM CHANGES: | The user will be prompted to press the TEST button again to confirm. If the user presses the TEST button again, the action is confirmed and the PC will reset. If the user presses the SERVICE button, the action is aborted and settings are discarded. |
| EXIT: | Exit to the Test Menu. |

Move the cursor to EXIT and press the TEST button to return to the Test Menu screen.

9-2-10 CALIBRATION TEST

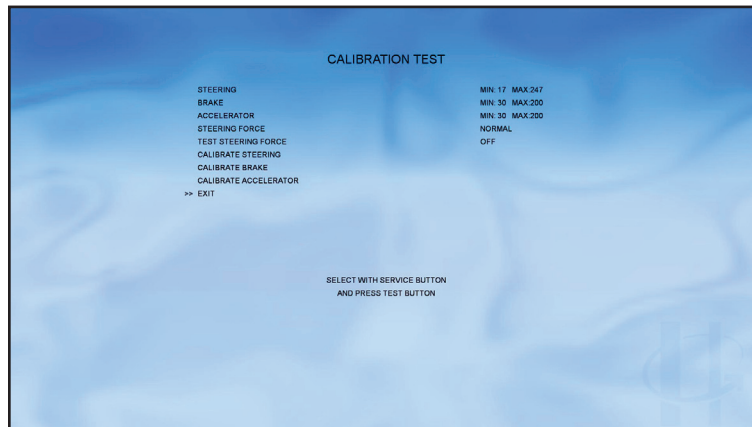

9-2 FIG. 12

Select 'Calibration Test' from the Test Menu screen to display the Calibration Test menu.

This test is used to calibrate devices such as the Steering Wheel and Pedals.

Use the SERVICE button to move the cursor to the desired test item.

Press the TEST button to enter the selected item.

STEERING: Displays the current Calibration settings for the Steering Wheel.
BRAKE: Displays the current Calibration settings for the Brake Pedal.
ACCELERATOR: Displays the current Calibration settings for the Accelerator Pedal.
STEERING FORCE: Sets the amount of force feedback used in the Steering Wheel when playing the game. There are four options available: OFF – No steering force will be used.

WEAK: Minimal steering force will be used.
NORMAL: Normal steering force will be used (recommended).
STRONG: Maximum steering force will be used.

TEST STEERING FORCE: **FULL LEFT:** Current steering feedback strength applied LEFT.
FULL RIGHT: Current steering feedback strength applied RIGHT.
OFF: No force applied to steering.

CALIBRATE STEERING: Starts the steering calibration routine. The wheel will automatically be calibrated by turning full left and then full right. No input is needed from the user once the test has been started.

CALIBRATE BRAKE: Starts the brake calibration routine. The user must follow the on screen prompts to fully depress and then release the brake pedal for 5 seconds.

CALIBRATE ACCELERATOR: Starts the accelerator calibration routine. The user must follow the on screen prompts to fully depress and then release the accelerator pedal for 5 seconds.

EXIT – Exit to the Test Menu.

Move the cursor to EXIT and press the TEST button to return to the Test Menu.

9-2-11 BOOKKEEPING

Select 'BOOKKEEPING' from the Test Menu to display the BOOKKEEPING menu.

Bookkeeping – Screen 1

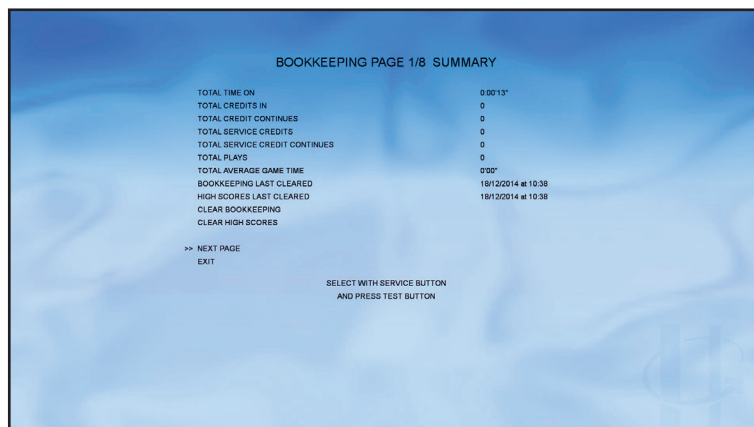

9-2 FIG. 13

This test is used to review statistical data from the system. It consists of 7 screens of data. Screen 1 contains an overview of the game play data.

| | |
|---------------------------------|------------------------------------------------------------------------------------------------------------------------------------------------------------------------------------------------------------------------------------------------------------------------------------------------------------------------------|
| TOTAL TIME ON: | The total time the cabinet has been switched on. Displayed in HH:MM:SS |
| TOTAL CREDITS IN: | The total number of coin credits entered. |
| TOTAL CREDIT CONTINUES: | The total number of coin credits used for continue games. |
| TOTAL SERVICE CREDITS: | The total number of service credits entered. |
| TOTAL SERVICE CREDIT CONTINUES: | The total number of service credits used for continue games. |
| TOTAL PLAYS: | The total number of games played. |
| TOTAL AVERAGE GAME TIME: | The average game time for all games. |
| BOOKKEEPING LAST CLEARED: | The time the bookkeeping meters were last cleared. |
| HIGH SCORES LAST CLEARED: | The time the high score tables were last cleared. (For the high score tables to be cleared, this must be done across all linked cabinets simultaneously). |
| CLEAR HIGH SCORES: | When selected, the user will be prompted to confirm. If the user confirms, the high score table is reset. Note, if there are cabinets linked together, the high score tables will only be reset if all linked cabinets perform this process simultaneously. If the user presses the SERVICE button, then no action is taken. |
| CLEAR BOOKKEEPING: | When selected, the user will be prompted to confirm. If the user confirms, the bookkeeping meters are reset to zero. If the user presses the SERVICE button, then no action is taken. |
| NEXT PAGE: | Proceed to bookkeeping screen #2. |
| EXIT: | Exits to the Test Menu. |

Use the SERVICE button to move the cursor to the desired test item.

Press the TEST button to enter the selected item.

Move the cursor to EXIT and press the TEST button to return to the Test Menu.

BOOKKEEPING <continued>

Bookkeeping – Screen 2 – Data on TOTAL PLAYS

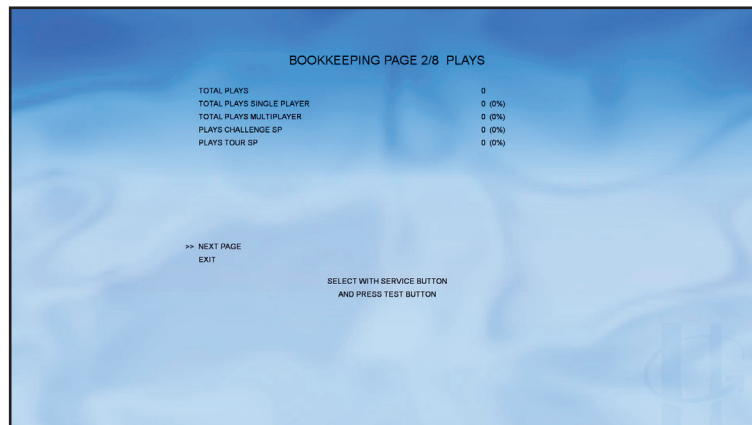

9-2 FIG. 14

This page displays accumulative individual modes and total plays. This is a cumulative total from the last point in time that the Bookkeeping was cleared.

| | |
|---------------------------|---------------------------------------------------------------------|
| TOTAL PLAYS | Total games played, all modes combined |
| TOTAL PLAYS SINGLE PLAYER | Total single player games played, Challenge and Tour modes combined |
| TOTAL PLAYS MULTIPLAYER | Total multiplayer mode games played |
| PLAYS CHALLENGE SP | Total single player challenge mode games played |
| PLAYS TOUR SP | Total single player tour mode games played |

Use the SERVICE button to navigate, and the TEST button to action changes to the following options.

| | |
|-----------|---------------------------------------------|
| NEXT PAGE | This will take you to Page 3 of Bookkeeping |
| EXIT | Return to the main Test Menu screen. |

Move the cursor to NEXT PAGE and press the TEST button to proceed to bookkeeping screen #3.

Move the cursor to EXIT and press the TEST button to return to the Test Menu.

BOOKKEEPING <continued>

Bookkeeping – Screen 3 – Data on AVERAGE GAME TIMES

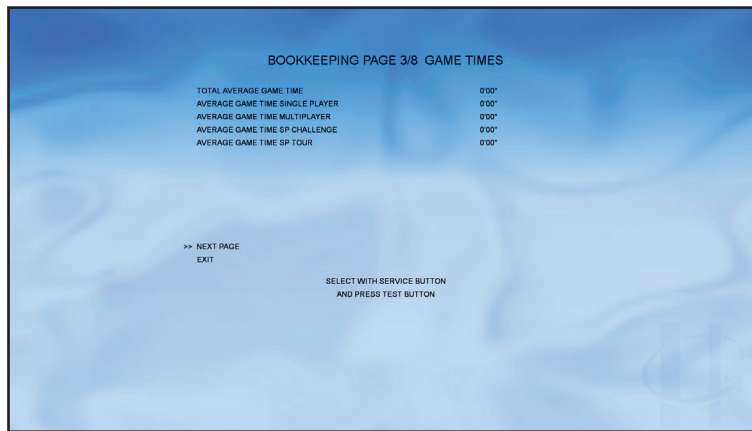

9-2 FIG. 15

This page displays total game time and average game times for single and multiplayer modes. This is a cumulative total from the last point in time that the Bookkeeping was cleared.

| | |
|---------------------------------|----------------------------------------------------|
| TOTAL AVERAGE GAME TIME | Total average game time, all modes combined |
| AVERAGE GAME TIME SINGLE PLAYER | Average game time for both single player modes |
| AVERAGE GAME TIME MULTIPLAYER | Average game time for all multiplayer games |
| AVERAGE GAME TIME SP CHALLENGE | Average game time for single player challenge mode |
| AVERAGE GAME TIME SP TOUR | Average game time for single player tour mode |

Use the SERVICE button to navigate, and the TEST button to action changes to the following options.

| | |
|-----------|---------------------------------------------|
| NEXT PAGE | This will take you to Page 4 of Bookkeeping |
| EXIT | Return to the main Test Menu screen. |

Move the cursor to NEXT PAGE and press the TEST button to proceed to bookkeeping screen #4.

Move the cursor to EXIT and press the TEST button to return to the Test Menu.

BOOKKEEPING <continued>

Bookkeeping – Screen 4 – Data on PLAYS BY DAY

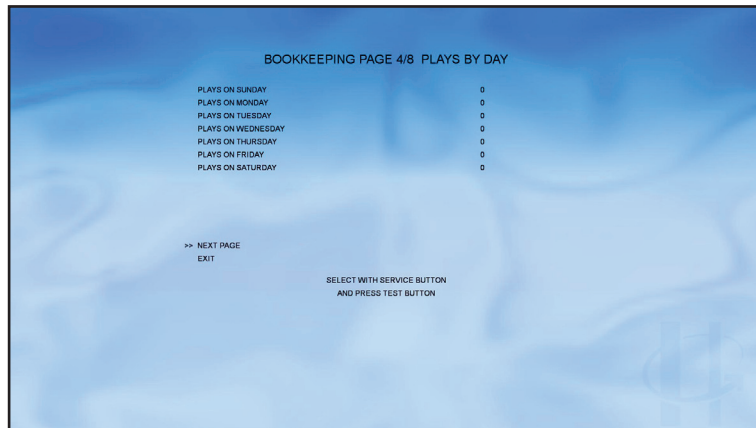

9-2 FIG. 16

This page displays breakdown of the games on individual days. This is a cumulative total of from the last point in time that the Bookkeeping was cleared.

| | |
|-------------------|----------------------------------|
| PLAY ON SUNDAY | Total games played on a Sunday |
| PLAY ON MONDAY | Total games played on a Monday |
| PLAY ON TUESDAY | Total games played on a Tuesday |
| PLAY ON WEDNESDAY | Total games played on a Thursday |
| PLAY ON THURSDAY | Total games played on a Sunday |
| PLAY ON FRIDAY | Total games played on a Friday |
| PLAY ON SATURDAY | Total games played on a Saturday |

Use the SERVICE button to navigate, and the TEST button to action changes to the following options.

| | |
|-----------|---------------------------------------------|
| NEXT PAGE | This will take you to Page 5 of Bookkeeping |
| EXIT | Return to the main Test Menu screen. |

Move the cursor to NEXT PAGE and press the TEST button to proceed to bookkeeping screen #5.

Move the cursor to EXIT and press the TEST button to return to the Test Menu.

Bookkeeping – Screen 5 – Data on PLAYS BY TIME

Move the cursor to NEXT PAGE and press the TEST button to proceed to bookkeeping screen #6.

Move the cursor to EXIT and press the TEST button to return to the Test Menu.

BOOKKEEPING <continued>

Bookkeeping – Screen 5 – Data on PLAYS BY TIME

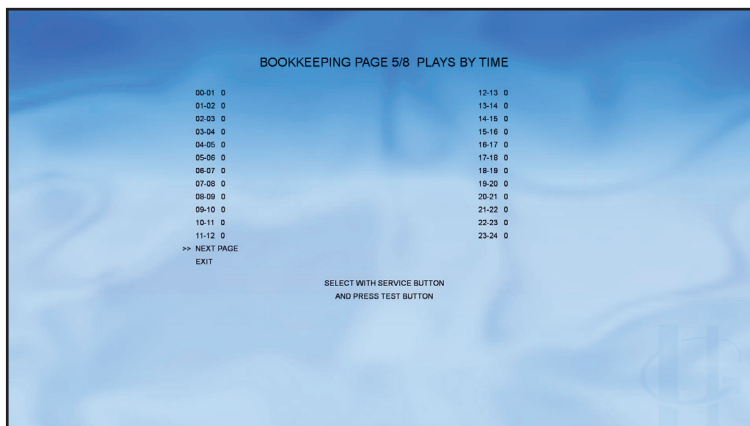

9-2 FIG. 17

This page displays a breakdown of the games into hourly periods. This is a cumulative total from the last point in time that the Bookkeeping was cleared.

Each hour is logged separately in 24 hour format therefore

00-01 logs games between 12am and 1am

00-02 logs games between 1am and 2am..... and so on

23-24 logs games between 11pm and 12am.

Use the SERVICE button to navigate, and the TEST button to action changes to the following options.

NEXT PAGE This will take you to Page 6 of Bookkeeping

EXIT Return to the main Test Menu screen.

Move the cursor to NEXT PAGE and press the TEST button to proceed to bookkeeping screen #6.

Move the cursor to EXIT and press the TEST button to return to the Test Menu.

BOOKKEEPING <continued>

Bookkeeping – Screen 6 – Breakdown of EVENTS

| BOOKKEEPING PAGE 6/8 EVENTS | |
|-----------------------------------------------------|---|
| SP_MIAMI_RACE_OFF | 0 |
| SP_LA_KNOCKOUT | 0 |
| SP_SAN_FRAN_RAMPAGE | 0 |
| SP_NEVADA_8BALL | 0 |
| SP_ASPEN_RACEOFF | 0 |
| SP_LA_8BALL | 0 |
| MP_MIAMI_RACE_OFF | 0 |
| MP_YOKOHAMA_KNOCKOUT | 0 |
| MP_SAN_FRAN_RAMPAGE | 0 |
| MP_LA_8BALL | 0 |
| MP_LA_RAMPAGE | 0 |
| MP_NEVADA_8BALL | 0 |
| >> NEXT PAGE | |
| EXIT | |
| SELECT WITH SERVICE BUTTON AND PRESS TEST BUTTON | |

9-2 FIG. 18

This page displays a breakdown of the games played on single player and multiplayer events. This is a cumulative total from the last point in time that the Bookkeeping was cleared.

| | |
|----------------------|----------------------------------------|
| SP_MIAMI_RACE_OFF | Single player Miami Race Off |
| SP_LA_KNOCKOUT | Single player Los Angeles Knockout |
| SP_SAN_FRAN_RAMPAGE | Single player San Francisco Demolition |
| SP_NEVADA_8BALL | Single player Nevada Crossroads |
| SP_ASPEN_RACEOFF | Single player Aspen Race Off |
| SP_LA_8BALL | Single player Los Angeles Crossroads |
| MP_MIAMI_RACE_OFF | Multiplayer Miami Race Off |
| MP_YOKOHAMA_KNOCKOUT | Multiplayer Yokohama Knockout |
| MP_SAN_FRAN_RAMPAGE | Multiplayer San Francisco Demolition |
| MP_LA_8BALL | Multiplayer Los Angeles Crossroads |
| MP_LA_RAMPAGE | Multiplayer Los Angeles Demolition |
| MP_NEVADA_8BALL | Multiplayer Nevada Crossroads |

Use the SERVICE button to navigate, and the TEST button to action changes to the following options.

| | |
|-----------|---------------------------------------------|
| NEXT PAGE | This will take you to Page 7 of Bookkeeping |
| EXIT | Return to the main Test Menu screen. |

Move the cursor to NEXT PAGE and press the TEST button to proceed to bookkeeping screen #7.

Move the cursor to EXIT and press the TEST button to return to the Test Menu.

BOOKKEEPING <continued>

Bookkeeping – Screen 7 – Data on EVENTS

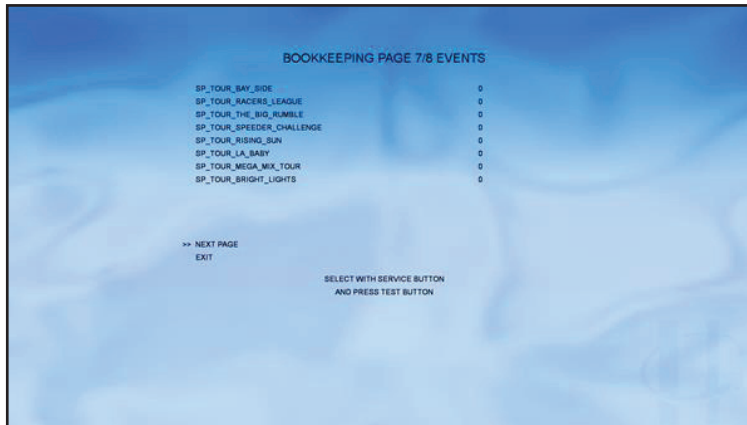

| BOOKKEEPING PAGE 7/8 EVENTS | |
|-----------------------------|---|
| SP_TOUR_BAY_SIDE | 0 |
| SP_TOUR_RACERS_LEAGUE | 0 |
| SP_TOUR_THE_BIG_RUMBLE | 0 |
| SP_TOUR_SPEEDER_CHALLENGE | 0 |
| SP_TOUR_RISING_SUN | 0 |
| SP_TOUR_LA_BABY | 0 |
| SP_TOUR_MEGA_MIX_TOUR | 0 |
| SP_TOUR_BRIGHT_LIGHTS | 0 |

>> NEXT PAGE
EXIT

SELECT WITH SERVICE BUTTON
AND PRESS TEST BUTTON

9-2 FIG. 19

This page displays a breakdown of the games played on single player tour mode events. This is a cumulative total from the last point in time that the Bookkeeping was cleared.

| | |
|---------------------------|--------------------------------------|
| SP_TOUR_BAY_SIDE | Single player tour Bayside |
| SP_TOUR_RACERS_LEAGUE | Single player tour Racers League |
| SP_TOUR_THE_BIG_RUMBLE | Single player tour The Big Rumble |
| SP_TOUR_SPEEDER_CHALLENGE | Single player tour Speeder Challenge |
| SP_TOUR_RISING_SUN | Single player tour Rising Sun |
| SP_TOUR_LA_BABY | Single player tour LA Baby |
| SP_TOUR_MEGA_MIX_TOUR | Single player tour Mega Mix Tour |
| SP_TOUR_BRIGHT_LIGHTS | Single player tour Bright Lights |

Use the SERVICE button to navigate, and the TEST button to action changes to the following options.

| | |
|-----------|---------------------------------------------|
| NEXT PAGE | This will take you to Page 8 of Bookkeeping |
| EXIT | Return to the main Test Menu screen. |

Move the cursor to NEXT PAGE and press the TEST button to proceed to bookkeeping screen #8.

Move the cursor to EXIT and press the TEST button to return to the Test Menu.

BOOKKEEPING <continued>

Bookkeeping – Screen 8 – Data on CARS

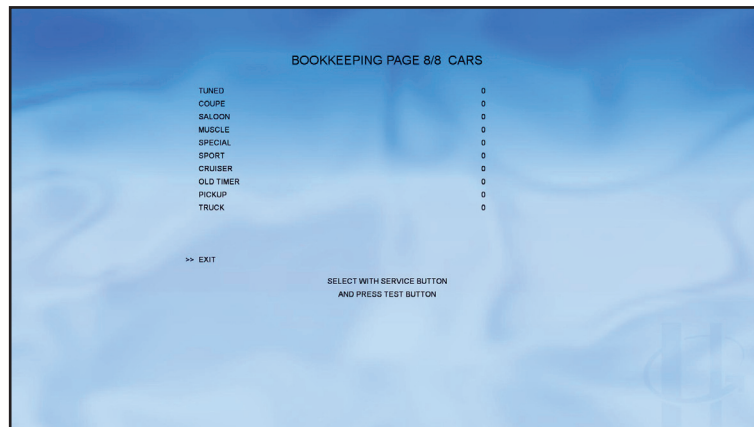

BOOKKEEPING PAGE 8/8 CARS

| | |
|-----------|---|
| TUNED | 0 |
| COUPE | 0 |
| SALOON | 0 |
| MUSCLE | 0 |
| SPECIAL | 0 |
| SPORT | 0 |
| CRUISER | 0 |
| OLD TIMER | 0 |
| PICKUP | 0 |
| TRUCK | 0 |

>> EXIT

SELECT WITH SERVICE BUTTON
AND PRESS TEST BUTTON

9-2 FIG. 20

This page displays a breakdown of the cars used in all game modes. This is a cumulative total from the last point in time that the Bookkeeping was cleared.

Use the SERVICE button to navigate, and the TEST button to action changes to the following options.

EXIT Return to the main Test Menu screen.

Move the cursor to EXIT and press the TEST button to return to the Test Menu.

9-2-12 CLOCK SETTINGS

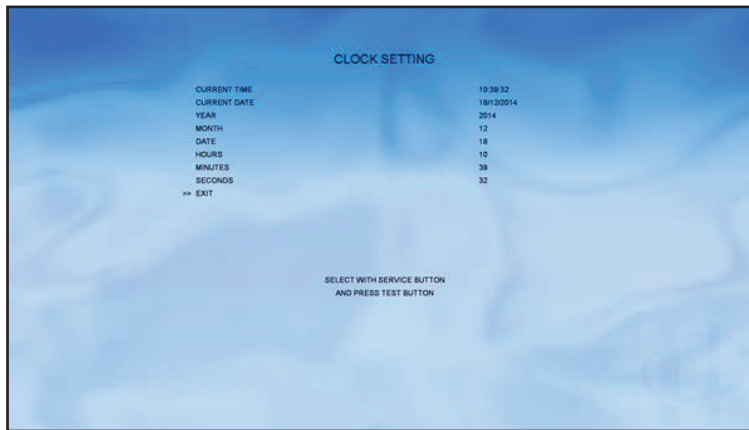

9-2 FIG. 21

Select 'CLOCK SETTING' from the Test Menu screen to enter the Clock Setting screen.

This screen is used to set the time and date of the system.

CURRENT TIME Shows the current time. Displayed in 24 hour clock format HH:MM:SS
CURRENT DATE Shows the current date. Displayed in the following format DD/MM/YYYY

Use the SERVICE button to move the cursor to the desired item.
Press the TEST button to test the selected item.

Use the service button to move the cursor to the item that needs to be changed and use the Test Button when that item is highlighted to change it to the desired setting. Changes made will automatically update CURRENT TIME and/or CURRENT DATE.

EXIT Press the Test button to return to the System Test Mode screen.

Move the cursor to EXIT and press the TEST button to return to the Test Menu.

9-2-13 GAME SETTINGS

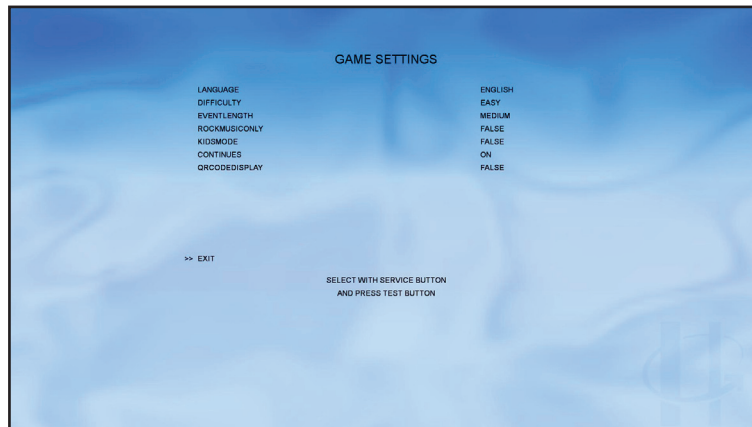

9-2 FIG. 22

Select 'GAME SETTINGS' from the Test Menu screen to enter the Game Settings screen.

This test is used to change the language of the in game text and voice, turn continues on or off and event length and difficulty.

NOTE TEST MENU text only displays in ENGLISH.

The following option is available from the Game Settings screen

| | |
|---------------|------------------------------------------------------------------------------------------------------------------------------------------------------------------|
| LANGUAGE | ENGLISH/FRENCH/ITALIAN/GERMAN/SPANISH |
| DIFFICULTY | EASY/MEDIUM/HARD |
| EVENTLENGTH | SHORT/MEDIUM/LONG/VERY_LONG |
| ROCKMUSICONLY | ON - Rock music only / OFF - All music tracks available |
| KIDSMODE | ON – Car will accelerate without pedal being pressed / OFF – Normal game play |
| CONTINUES | ON – Player will be able to continue a tour if they fail to complete an event OFF – Player will have to place 1st, 2nd or 3rd to progress and complete a tour |
| QRCODEDISPLAY | ON – QR Code displayed at race results to register progress at www.segascors.com / OFF – QR Code is not displayed |

Use the SERVICE button to navigate, and the TEST button to action changes to the following options.

EXIT Return to the main Test Menu screen.

Move the cursor to EXIT and press the TEST button to return to the Test Menu.

9-3 MOTION SAFETY SYSTEM

Showdown is fitted with a number of safety features to ensure the safety of players and operators. Players are shown a graphical representation of the safety conditions before each game.

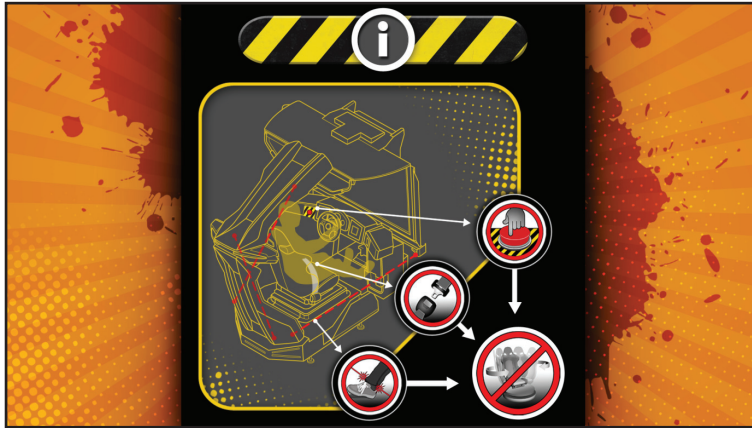

9-3 FIG. 01

Safety Feature Screen

If motion is disabled by the system the player is informed graphically of the reason for the lack of movement. Note Seatbelt icon is only shown where factory fitted

Motion Stop Icon



Motion Stop Icon

9-3 FIG. 02

Motion Stop Icon

Motion Stop Button pressed icon



Motion Stop Icon - (Motion Stop Button Pressed)

9-3 FIG. 03

9-3-1 SAFETY CONDITIONS

OPTICAL SAFETY SENSORS

Optic safety sensors are fitted so that the areas to the side of the seat and at the rear of the seat are constantly monitored.

If or when the infrared beams are broken, the:-



9-3-1 FIG. 01

1. Motion stops immediately at the current position and the Motion Servo is turned off – Seat can now be manually moved if required.
2. Player is warned on screen that motion has been disabled and the sensor beam icon is displayed
3. Motion will not return until all sensors are cleared
4. When clear players are informed on screen of the return to motion and the seat will slowly move to the centre position and motion will resume at low intensity slowly returning to full intensity
5. If the beam is still broken at the end of a game the servo will not be powered until the next credit is consumed resulting in the free movement of the seat during the attract sequence. If this occurs the seat will centre at the start of the next game.

MOTION STOP BUTTON

This is fitted to the Control Panel, left of the Steering Wheel. When operate by the player disables the motion to the seat.



9-3-1 FIG. 02

1. Motion is stopped immediately and the seat will slowly move to the centre position.
2. Player is warned on screen that motion has been disabled and the Motion stop button icon is displayed
3. Motion will not be returned until the motion stop button is pressed again
6. When the button is pressed the player is informed on screen of the return to motion and seat movement will resume at low intensity slowly returning to full intensity

SEAT BELT (IF FITTED)

The seatbelt (if fitted) is attached to the seat and the player is required to keep it fastened during gameplay. If the belt is unfastened during play:



9-3-1 FIG. 03

1. Motion is stopped immediately and the seat will slowly move to the centre position.
2. Player is warned on screen that motion has been disabled and the seat belt button icon is displayed
3. Motion will not be returned until the motion stop button is pressed again
4. When the button is pressed the player is informed on screen of the return to motion and seat movement will resume at low intensity slowly returning to full intensity

MULTIPLE SAFETY CONDITIONS

These safety features can engage at the same time. If this occurs the player is informed of each issue via the onscreen warning system and as each item is cleared the appropriate icon is removed. When all issues are cleared motion seat movement will resume at low intensity slowly returning to full intensity. When multiple systems are engaged the sensor beams take priority so the seat Servo will not be engaged until all sensors is cleared. The example below illustrates both the breaking of a safety sensor beam and the pressing of the motion stop button.



Sensor Beam Broken and Motion Stop Button Presses

9-3-1 FIG. 04

9-4 TROUBLESHOOTING

Problem

Linked cabinets will not sync together in the attract mode.

Causes

1. Network cables are not connected.
2. The cabinets are using security keys from different regions
3. Network cables are faulty.

Solutions

1. Reconnect the network cables to each cabinet.
2. Ensure each cabinet has the same region which is viewable on the System Information page. Cabinets will only link together from the same region.
3. Replace the faulty network cables. Contact the company from whom the unit was purchased.

Problem

Cabinets are unable to start a Multiplayer session together.

Causes

1. Network cables are not connected.
2. Cabinets have different Track Packs enabled.
3. Cabinet ID's are not set up correctly.

Solutions

1. Ensure network cables are properly connected to the cabinets.
2. Go into Game Settings in the Test Menu and ensure each cabinet is set to the same Track Pack.
3. Go into the Network Settings and ensure each cabinet has a different Cabinet ID. Confirm the settings and then the cabinets will reset with the new changes saved.

Problem

The Steering Wheel does not work correctly in the game.

Causes

1. The Steering Wheel has not been calibrated correctly.

Solutions

1. Go into the Calibration Settings in the Test Menu and select Calibrate Steering.

Problem

The Pedals do not work correctly in the game. Vehicles move forward or backwards with no player input.

Causes

1. The Pedals have not been calibrated correctly.

Solutions

1. Go into the Calibration Settings in the Test Menu and select Calibrate Brake and follow the on screen instructions. Once this has been done, select Calibrate Accelerator and follow the on screen instructions.

Problem

No audio can be heard in either the attract mode, or throughout the game.

Causes

1. The audio level has not been correctly set with the Hardware Volume Control inside the cash drawer.
2. The volume levels within the Sound Settings in the Test Menu have not been set correctly.

Solutions

1. Go into the cash drawer and adjust the Hardware Volume Control until audio in the game can be heard.
2. Enter the Sound Settings menu from the Test Menu and check that all volume levels are set to the appropriate levels. Options are available within this menu to test the volume levels of each setting to make sure each are correct.

Problem

High Score Tables have not been cleared after attempting to clear them in the Bookkeeping menu.

Causes

1. The high scores have only been cleared on one cabinet when multiple cabinets are linked together.

Solutions

1. When multiple cabinets are linked together, the high score tables will only be cleared if the process is done on all connected machines at the same time. Each cabinet must be in the Bookkeeping menu, and then Clear High Scores should be selected on each one and then confirmed. If any cabinets are left in the attract mode during this, the high score tables will not be cleared.

Problem

An error message appears in the game that says: "IO BOARD NOT DETECTED".

Causes

1. The IO USB cable has become disconnected.

Solutions

1. Reconnect the IO USB cable to the game board and perform a power cycle.

Problem

An error message appears in the game that says: "SECURITY KEY NOT DETECTED".

Causes

1. The security key has become disconnected.

Solutions

1. Reconnect the security key to the game board and perform a power cycle.

9-5 ERROR MESSAGES

The game is equipped with an integral fault monitoring system. Each time an identified fault is detected an error message is displayed on screen.

Below is a table showing possible common conditions. Please refer to them as a guide.

If the ERROR Code/Message displayed on screen is not supported by this manual then please contact your Sega Service Centre for diagnostics.

| Error Message | Description | Troubleshooting |
|-------------------------------|-------------------------------------------------------------------------------------------------|----------------------------------------------------------------------------------------------------------------------|
| ERROR! NO SECURITY KEY FOUND | The system was unable to detect a valid security key | |
| | Check USB Security Key | |
| ERROR! INCORRECT KEY INSERTED | The system found a security key but the configuration is not valid for this product | Check USB Security Key |
| ERROR! SECURITY FAILURE | The system security has detected security issues with the installed software | Restore software from recovery USB stick |
| ERROR! IO BOARD FAILURE | The I/O Board was not detected on power up | Check I/O Board, Power supply and harnessing |
| ERROR! IO BOARD DISCONNECTED | The IO Board was detected on power up, but has subsequently been disconnected from the software | Check I/O Board, Power supply and harnessing |
| ERROR! UPDATE COPY FAILED | The shell was unable to create main and backup copies of the game or during install or update | Check USB Install Media and re-apply update or re-install. If still failing restore software from USB Recovery stick |
| ERROR! INVALID SHELL UPDATE | | |
| | The shell Update on the USB stick is not a valid update | Check USB Install Media and re-apply update |
| ERROR! UPDATE COPY FAILED | The shell was unable to create main and backup copies of the game or during install or update | Check USB Install Media and re-apply update or re-install. If still failing restore software from USB Recovery stick |

| | | |
|------------------------------------------|-------------------------------------------------------------------------------------------------------------------------------------------------------------------------------------------------------------------|------------------------------------------------------------------------------------------------------------------------------------------------------------------------------------------|
| ERROR! NO GAME INSTALLED | The shell was unable to find a game on the disk to launch. A game needs to be installed. | Restore software from USB Recovery stick |
| ERROR! NO SHELL INSTALLED | Launcher was unable to find a Shell on the disk to launch. A Shell needs to be installed. | Restore software from USB Recovery stick |
| GAME ERROR | The game was unable to launch or has terminated abnormally. On reboot the game will be reinstalled from back up. If it fails again no further attempt to launch the game will be made on subsequent power cycles. | Restore software from USB Recovery stick |
| ERROR! MOTION SEAT COMMUNICATION FAILURE | The shell was unable to communicate with the motion base system | Check: Harnessing between game-board and USB to serial convertor board. USB to serial convertor board Check Motion Controller transformer, Power supply and harnessing. |

10 VIDEO DISPLAY

CAUTION

The LCD display screen is adjusted prior to leaving the factory. Avoid any unnecessary adjustment.

IMPORTANT

- If the adjustment method in this manual does not resolve the problem contact the customer service number in this manual or your supplier.
- Do not stick tape, stickers or anything else onto the screen. Any kind of adhesive may damage the surface of the screen.

10-1 GENERAL DESCRIPTION

This specification applies to the 64.5 inch Color TFT-LCD Module P650HVN02.4. This LCD module has a TFT active matrix type liquid crystal panel 1920 x 1080 pixels, and diagonal size of 64.5 inch. This module supports 1920 x 1080 mode. Each pixel is divided into Red, Green and Blue sub-pixels or dots which are arranged in vertical stripes. Gray scale or the brightness of the sub-pixel color is determined with a 10-bit gray scale signal for each dot.

The P650HVN02.4 has been designed to apply the 10-bit 2 channel LVDS interface method. It is intended to support displays where high brightness, wide viewing angle, high color saturation, and high color depth are very important.

* General Information

| Items | Specification | Unit | Note |
|------------------------|-----------------------------------|--------|-----------|
| Active Screen Size | 65 | Inch | |
| Display Area | 1428.48 (H) x 803.52 (V) | mm | |
| Outline Dimension | 1508.0 (H) x 878.0 (V) x 12.8 (D) | mm | 1 |
| Driver Element | a-Si TFT active matrix | | |
| Display Colors | 10 bit (8bit+FRC), 1073.7M | Colors | |
| Number of Pixels | 1920x1080 | Pixel | |
| Pixel Pitch | 0.744 | mm | |
| Pixel Arrangement | RGB vertical stripe | | |
| Display Operation Mode | Normally Black | | |
| Display Orientation | Portrait/LandscapeEnable | | |
| Surface Treatment | AG | | Haze = 2% |

10-2 CLEANING THE SCREEN

CAUTION

- Since the LCD display screen is susceptible to damage, pay careful attention to its handling. When cleaning, refrain from using water or volatile chemicals.
- Do not climb onto the control panel. This could lead to injuries, such as bumping your head.
- When reaching across the control panel to clean the screen there is a risk of hurting your shoulder or arm. Use a mop with a non-feathery, soft, dry cloth mop head and wipe the surface of the screen.

When the screen surface becomes dirty with dust, etc., clean it by using a soft cloth such as gauze. When water, and volatile chemicals such as benzene, thinner, etc., spill on the screen surface, it may be subject to damage, therefore, do not use them.

Also, since the surfaces are susceptible to damage, refrain from rubbing them with a hard material or using a duster. If the screen is especially dirty, call in a professional cleaner.

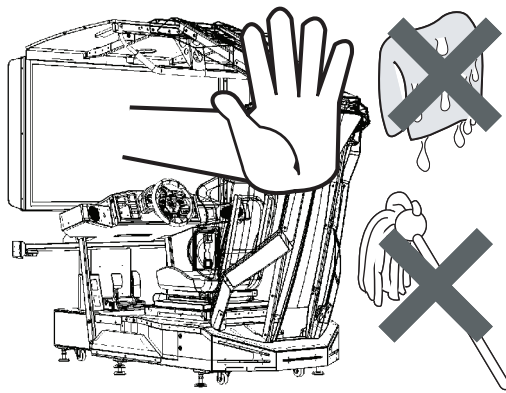

FIG. 10-1

11 CONTROL UNITS

WARNING

- When working with the product, be sure to turn the power off. Working with the power on may cause an electric shock or short circuit.
- Be careful not to damage the wires. Damaged wires may cause an electric shock, short circuit or present a risk of fire.
- Do not touch any parts that are not specified in these directions. Touching unspecified locations may lead to electric shock or cause short circuits.
- This work should be performed by site maintenance personnel or other skilled professionals. Work performed by non-technical personnel can cause a severe accident such as an electric shock.
- Exercise due caution in performing soldering procedures. If soldering iron is handled carelessly, there could be fires or burns.
- Proceed very carefully when heating thermal contraction tube. Careless operations can result in fires or burns.

CAUTION

- When fastening plastic parts, be careful not to tighten screws and nuts excessively. Otherwise parts may be damaged, resulting in injuries from fragments, etc.
- Be careful not to get hand or finger caught when removing or attaching the parts.
- Disconnection and connection of connectors will be performed within the narrow cabinet space. Take due care not to scratch or otherwise injure yourself.
- Take care when carrying the removed Control Units. Such heavy lifting carries a risk of injury to back or shoulders.

STOP IMPORTANT

- After the Potentiometer has been replaced, be sure to set the values on the test mode calibration screen and the input test screen and check variations in the volume value.
- Handle parts inside the Control Unit very carefully. Be especially careful to avoid damage, deformation or loss of these parts. If any one of these parts is lost or defective, it can result in damages and/or faulty operations.

CAUTION

- When fastening plastic parts, be careful not to tighten screws or nuts excessively. If these are tightened to excess, parts could be damaged, resulting in injuries from fragments, etc.
- After the unit has been disassembled and reassembled again, check carefully that the unit has been reassembled correctly.
- Be sure to inspect the outer covers on both gear and brake units.
- Assemble so that there is no gap between the L and R covers. If there is a gap or rattling, the players could get fingers or hands caught, resulting in injury.

IMPORTANT

- Once the product has been disassembled, use slack preventive agent (product No. : 090-0012-N). Coat screws with suitable amounts of this agent and then tighten them. If this agent is not used, the product might start rattling or come apart.
- Use the slack preventive agent prescribed in these instructions. If any other agent is used, there could be chemical changes that inhibit the use of screws and part surfaces could be damaged.
- Be careful not to damage or lose small parts or screws.
- When a part has been replaced, be sure to always make adjustments and check conditions in Test Mode.

11-1 CONTROLLER - EXPLODED DIAGRAM

The exploded diagram below shows the Active Steering Wheel Assy. Each part is tagged with a part number. Please quote this number when ordering spare parts.

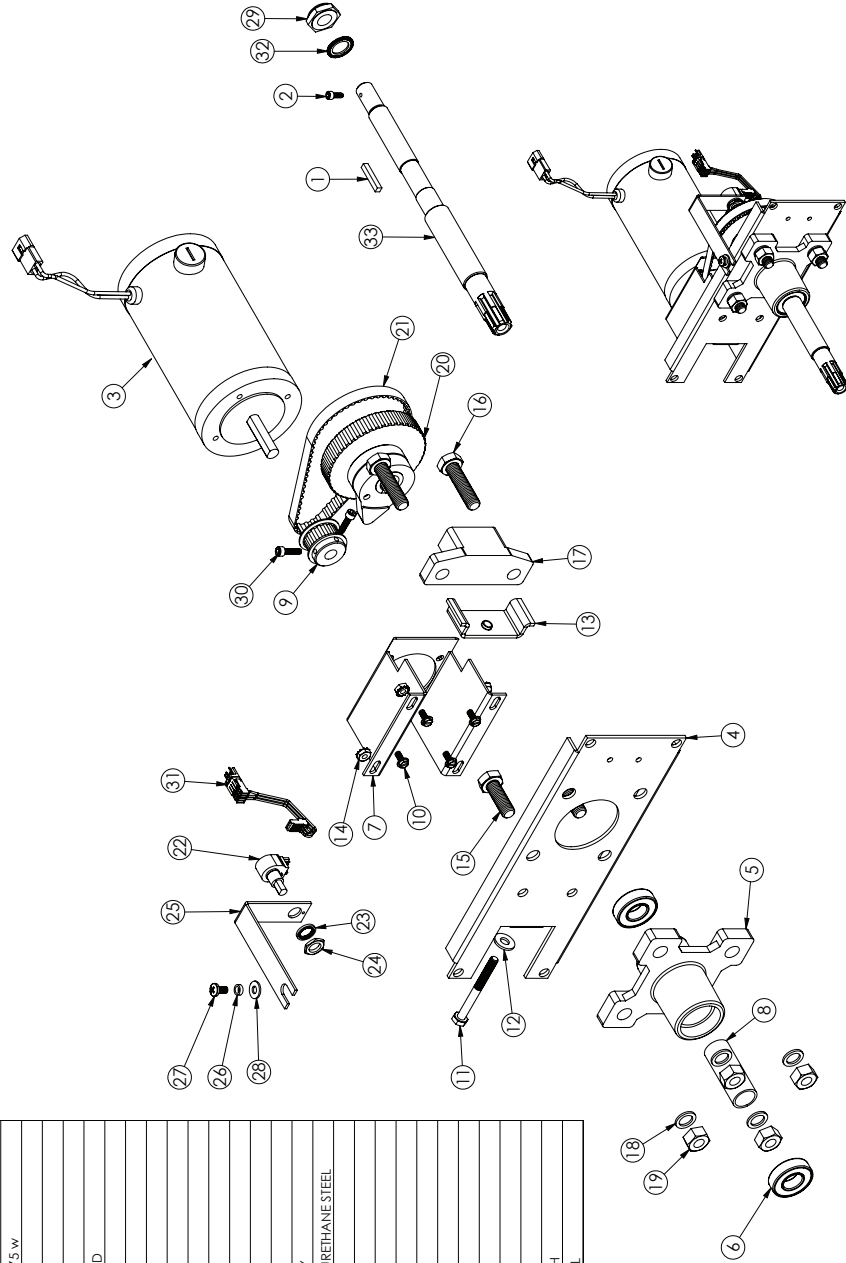

FIG. 11-1

| ITEM NO. | QTY. | PART NO. | DESCRIPTION |
|----------|------|------------|-----------------------------------------------|
| 1 | 1 | 50-2092-00 | KEY, SHAFT .4MM X 4MM X 25MM |
| 2 | 1 | 43-1170-00 | SCREW, #6-32 X 3/8" SHCS |
| 3 | 1 | 50-4043-00 | MOTOR & CONNECTOR ASY. |
| 4 | 1 | 50-4016-00 | WHEEL MTG. BRACKET |
| 5 | 1 | 50-8129-00 | BEARING HOUSING |
| 6 | 2 | 50-8130-00 | BEARING, .9843 ID X 1.259 OD X .1575 W |
| 7 | 1 | 50-8465-00 | MOTOR MTG. BRACKET |
| 8 | 1 | 50-2659-00 | BEARING SPACER |
| 9 | 1 | 50-4040-00 | PULLEY, 1.6T, ALUMINUM |
| 10 | 4 | 43-0188-00 | SCREW, #8-32 X 3/8" HEX WASHER HD |
| 11 | 1 | 43-0576-00 | SCREW, .06 X 60MM HHCS |
| 12 | 1 | 90-1208-00 | 5/16 FLAT WASHER, .06T ZINC PLT |
| 13 | 1 | 50-2545-00 | BRACKET BELT TENSIONER |
| 14 | 4 | 42-0093-00 | NUT, 10-32 HEX SEMS, ZINC PLTD |
| 15 | 2 | 43-0117-00 | SCREW M10 X 30MM HHCS |
| 16 | 2 | 43-0978-00 | SCREW, M10 X 40MM HHCS |
| 17 | 1 | 50-8145-00 | DIE CAST WHEEL STOP, W/BUMPERS |
| 18 | 4 | 43-0034-00 | LOCKWASHER M10 RIBBED |
| 19 | 4 | 43-0035-00 | NUT, HEX M10 |
| 20 | 1 | 50-4045-PL | STOPPER PIE CAM & PLASTIC PULLEY |
| 21 | 1 | 50-4041-90 | TIMING BELT FOR STEERING WHEEL URETHANE STEEL |
| 22 | 1 | 50-2670-00 | 5K POT, NEI "SENSORCUBE" |
| 23 | 1 | 43-0018-00 | LOCKWASHER, INT, 3/8" X 9/16" |
| 24 | 1 | 43-0014-00 | HEX NUT 3/8"-24 X 3/32 THK |
| 25 | 1 | 50-4018-00 | POT, MTG. BRACKET |
| 26 | 1 | 50-4032-00 | SPACER, POT MTG. BRACKET |
| 27 | 1 | 43-0184-00 | SCREW, #10-32 X 3/8" PHPNHD |
| 28 | 1 | 43-0995-00 | #10 FLAT WASHER |
| 29 | 1 | 43-0232-00 | NUT, HEX NYLOCK 1/2-20 |
| 30 | 2 | 43-1089-00 | SCREW, #8-32 X 5/8" SHCS |
| 31 | 1 | 50-4042-10 | HARNESS, FOR NEI POT |
| 32 | 1 | 43-1554-00 | STAR WASHER M14 EXTERNAL TOOTH |
| 33 | 1 | 50-4014-10 | SEGA SHAFT 270 DEG ACTIVE WHEEL |

11-2 BRAKE AND ACCELERATOR UNIT

WARNING

When working with the product, be sure to turn the power off. Working with the power on may cause an electric shock or short circuit. However, the unit must be switched on when using test mode. Do not touch any part of the unit except those areas indicated.

Be careful not to damage the wires. Damaged wires may cause an electric shock, short circuit or present a risk of fire.

This work should be performed by site maintenance personnel or other skilled professionals. Work performed by non-technical personnel can cause a severe accident such as an electric shock.

To prevent accidents while working or while operating the product after it has been installed, be sure not to conduct any procedures other than those given in this manual. There are cases in which procedures not covered in this manual require special tools and skills.

If a procedure not given in this manual is required, request service from the office given in this manual or from the point of purchase.

IMPORTANT

Be sure to perform volume's move value setting in the Input Test in the Game Test Mode after replacing or adjusting the Volume.

If the accelerator or brake pedals are not functioning correctly, you may need to adjust the positioning of the volume or replace it with a new one. In addition, you should apply grease to the gear contacts and spring parts once every three months.

When the accelerator pedal is not being pressed, the accelerator volume should have a value of 30H or less. When the pedal is being pressed, the value should be C0H or greater.

When the brake pedal is not being pressed, the value should be 35H or less. When the pedal is being pressed, it should be D0H or more. You can view these values in test mode. Note that the unit must be switched on to use test mode. Do not touch any part of the unit except those areas indicated when the unit is switch on, as there is a danger of electrical shock or short-circuit.

For this task, you will need a Phillips-head screwdriver (for M4, M5 screws).

Adjusting Procedure

- 1 On the accelerator and brake pedal unit, remove the two truss screws and lift off the front cover.

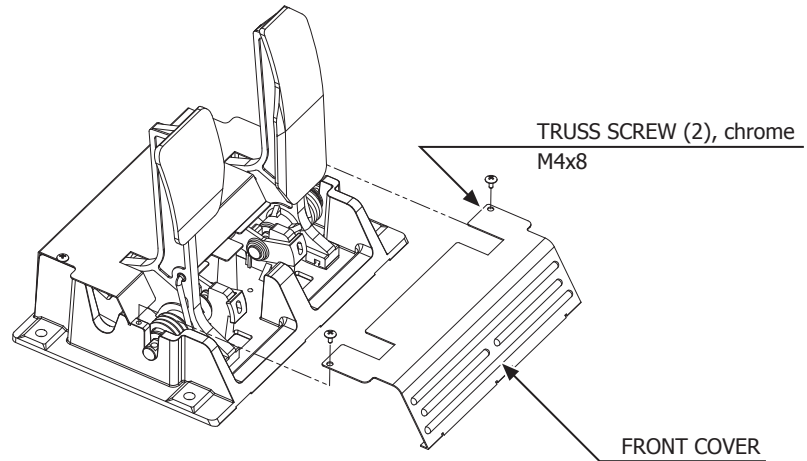

FIG. 11-2a

- 2 Loosen the single screw that secures the potentiobase, and move the base to adjust the volume values.

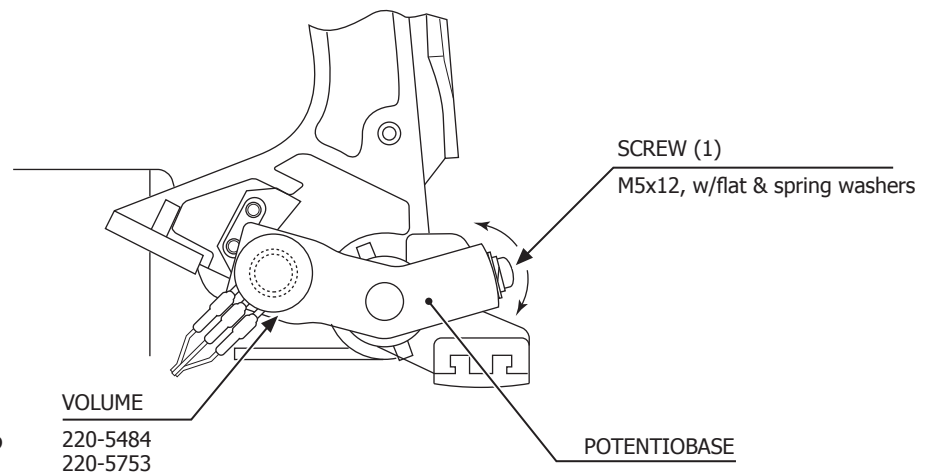

FIG. 11-2b

- 3 Secure the potentiobase.
- 4 Configure the volume values on the INPUT ASSIGNMENTS screen in Game Test Mode.
- 5 Check that the values change smoothly in response to pedal input.

11-3 ADJUSTING/REPLACING THE VOLUME POT

Replacing the Volume

- 1 Switch off the unit.
- 2 Remove the two screws and lift off the potentiometer cover.

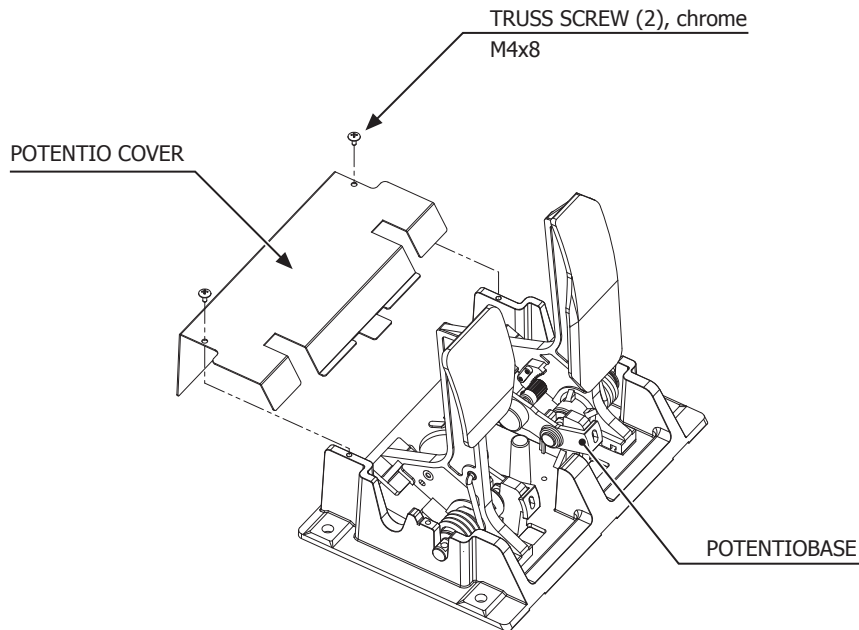

FIG. 11-3a

- 3 Detach the connector from the volume to be replaced.
- 4 Remove the single screw that secures the potentiometer base. (see 11-3 FIG. a).
- 5 Without detaching the volume, remove the potentiometer base. (see 11-3 FIG b).
- 6 The wire connected to the volume pot will be reused. Use a tool such as a pair of snips or cutters to remove the old heatshrink tubes which cover the contacts.

-
- 7** Use a soldering iron to melt the solder and separated the wires from the old volume pot. Be very careful when using a soldering iron.

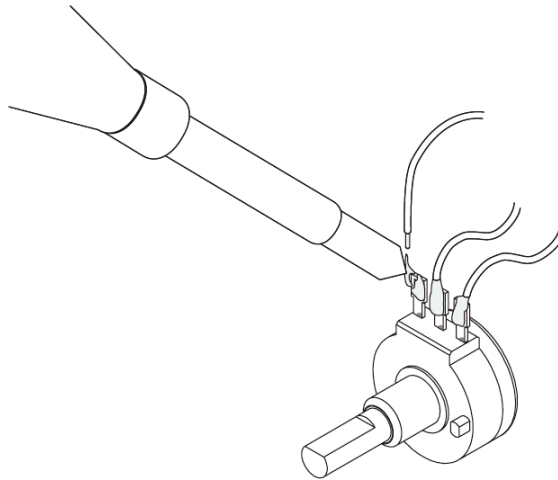

FIG. 11-3b

-
- 8** If the exposed conductive wire at the end is less than 5mm, use a tool such as a wire stripper or cutter to cut the wire insulation back to a workable length. Place new sleeving over the wire before resoldering them to the pot.
-
- 9** Once soldered, cover the bare contacts with the sleeving. If heatshrink is used, apply heat from an appropriate hot air blower to shrink the sleeving tightly over the contacts.
-
- 10** Reassemble the pot to the pot bracket by working in reverse order of these instructions. Refer to the POT VOLUME ADJUSTMENT section of this manual.

11-4 GREASING

STOP IMPORTANT

Use only the specified grease. Using any other kind of grease can result in damage to parts.

Once every three months, you should apply grease to the gear contacts and spring parts.
Use Grease Mate-brand spray grease (Part No.: 090-0066).

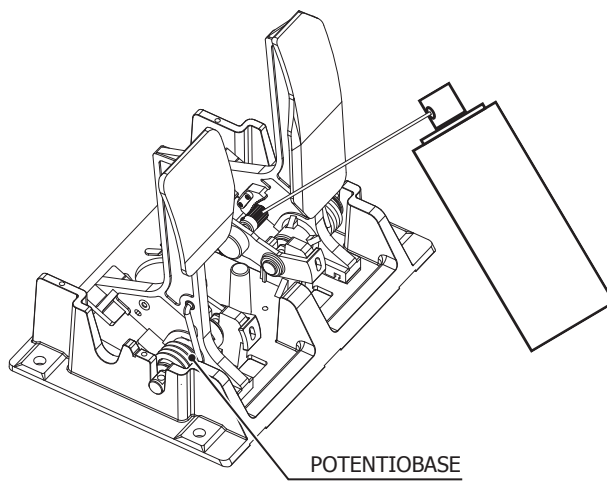

FIG. 11-4

11-5 MOTION BASE AND SEAT

11 CONTROL UNIT

WARNING

- When working with the product, be sure to turn the power off. Working with the power on may cause an electric shock or short circuit. However, the unit must be switched on when using test mode. Do not touch any part of the unit except those areas indicated.
- Be careful not to damage the wires. Damaged wires may cause an electric shock, short circuit or present a risk of fire.
- This work should be performed by site maintenance personnel or other skilled professionals. Work performed by non-technical personnel can cause a severe accident such as an electric shock.
- To prevent accidents while working or while operating the product after it has been installed, be sure not to conduct any procedures other than those given in this manual. There are cases in which procedures not covered in this manual require special tools and skills.
- If a procedure not given in this manual is required, request service from the office given in this manual or from the point of purchase.
- Always keep hands, fingers and items of clothing away from the integral workings of the Seat Mech when apply power! Do not under any circumstances work within the assembly when powered.

IMPORTANT

Use only the specified grease. Using any other kind of grease can result in damage to parts.

Once every three months or 15000 plays, a periodic inspection should be carried out by an qualified engineer specialising in this field.

Accessing the Motion Base

1 Remove power from the machine and disconnect te power cable.

2 Remove both Left and Right covers. - Unscrew the (5) M4x12 Hex Key bolts from the outside edges of the cover plate and the single M8x20 Hex Key bolt from the top rear surface.

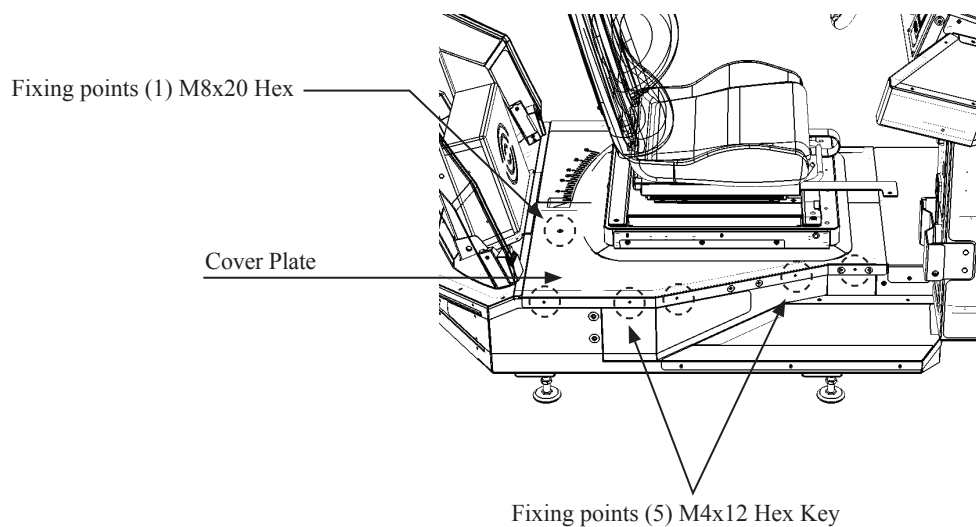

3 When all 6 fixings have been removed, carefully slide out the right hand upper cover.

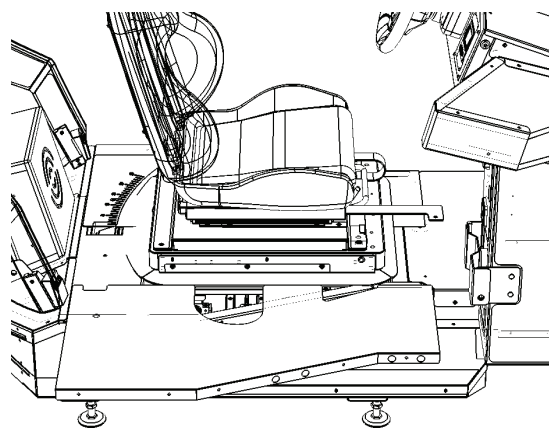

- 4** Remove the (3) M8x20 Hex Bolts from the side cover right. Once fixings have been removed, slide the cover in an upward direction to remove.

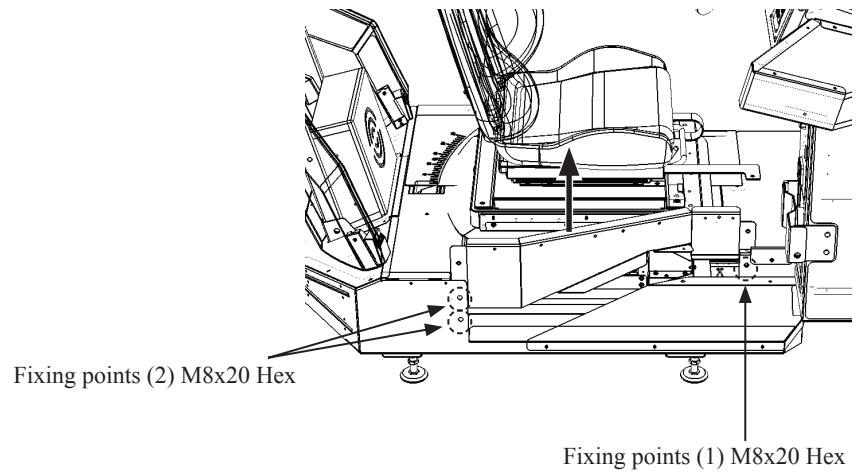

- 5** Carefully push the seat to it's furthers point to reveal the Inspection Cover.

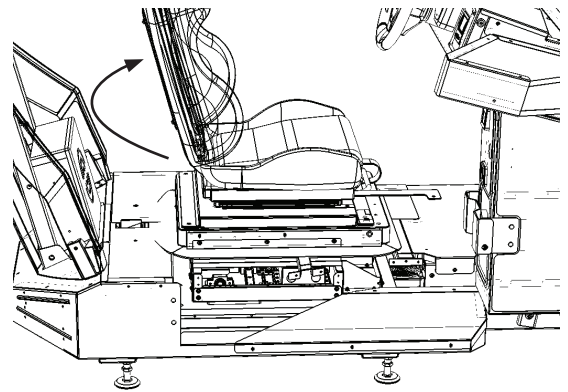

- 6** Locate the Inspection Cover and remove the M4x12 Machines Screws which secure the cover to the base.. Remove the cover.

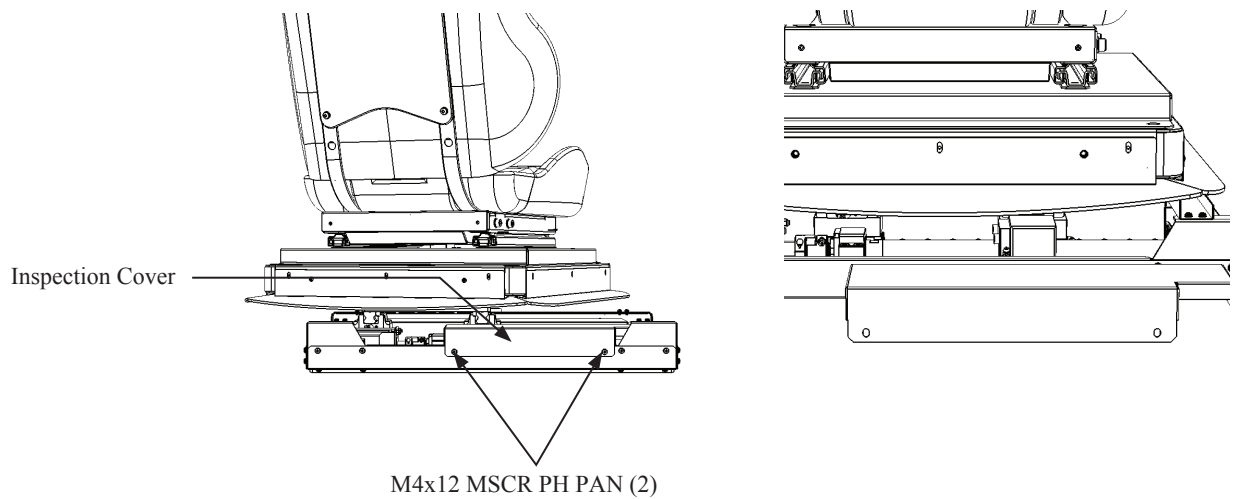

Greasing

Grease

Please apply to all areas except the ringball and the cross roller rings.
grease(recommended grease AFB-LF)

- 1 Once the Inspection cover has been removed, located the Ball Screw and apply a generous amount of Grease,

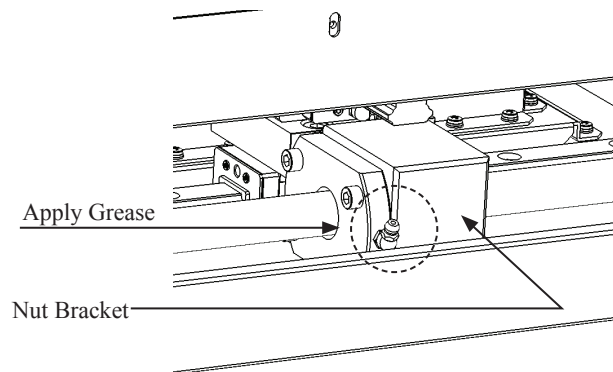

- 2 Locate the two LM Ball guide screws and apply the recommended grease to both areas. Do this for both Left and Right positions..

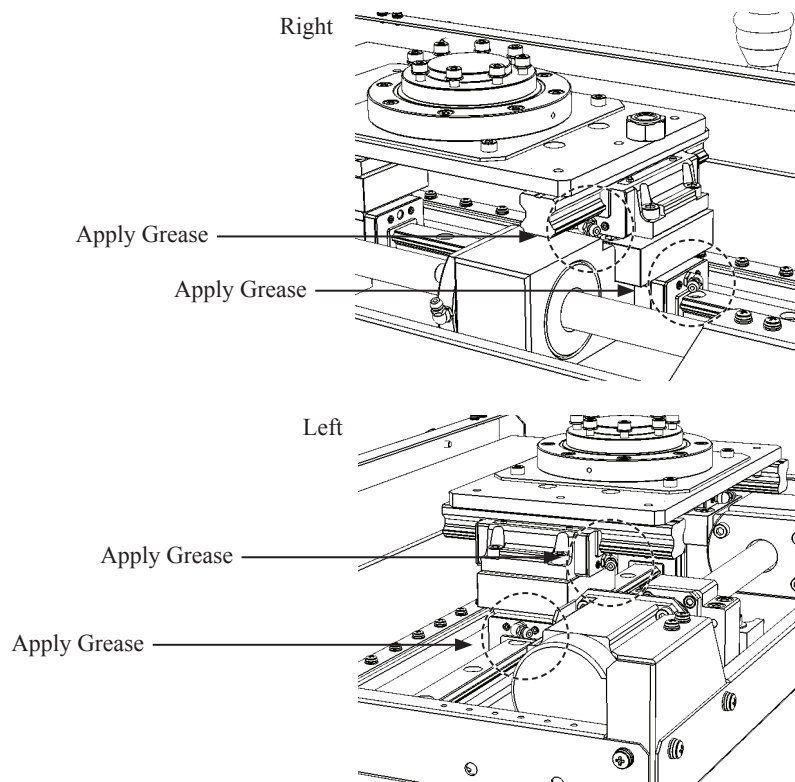

- 3 Once all areas have been greased. - Re assemble in reverse order by following instructions 6 to 1 on the previous pages.

Periodic Inspection

STOP IMPORTANT

Once every three months or 15000 plays, a periodic inspection should be carried out by an qualified engineer specialising in this field.

1. Check for loose bolts and nuts in these areas.
 - link ball fixing bolt/nuts (swing table/link ball, linkball/rotation base fixings)
 - cross roller fixing bolts (swing table/cross roller fixings)
 - LM guide fixing nut
 - nut bracket fixings(loose bolt causing shaking)
 - motor fixed situation - motor base/motor + spacer flange and motor base/swing base box fixing.
 - coupling fixing bolt (coupling/ball screw axis and coupling/motor fixing)
 - support unit (BK,BF) fixing bolts
 - form bumper fixing situation
2. Check for any damage or wear and tear within the mechanism.
3. Any noise during operation.
4. Any variable resistance when moving ball screw nut (check if there is no variable resistance on ball screw area, when vibrating swing table)
5. Please remove any debris using a lint free cloth.

12 COIN HANDLING

This product is supplied with either an electronic coin validator (particular to Europe) or a mechanical coin acceptor (particular to USA and Asia). Identify which coin acceptor is being used and consult the relevant information within this section of the manual.

Handling the Coin Jam

If the coin is not rejected when the REJECT button is pressed, open the coin chute door and open the selector gate. After removing the jammed coin, put a normal coin in and check to see that the selector correctly functions.

12-1 CLEANING THE COIN SELECTOR

STOP IMPORTANT

- Remove and clean smears by using a soft cloth dipped in water or diluted chemical detergent and then squeezed dry.
- Never apply machine oil, etc. to the Coin Selector.
- After cleaning the Coin Selector, insert a regular coin in the normal working status and ensure that the selector correctly functions.

The Coin Selector should be cleaned once every 3 months.
When cleaning, follow the procedure below:

- 1 Turn the power for the machine OFF. Open the Coin Chute Door
- 2 Remove the Coin Selector from the Coin Chute Door
- 3 Open the gate and dust off by using a soft brush (Small soft Paint Brush, etc.)

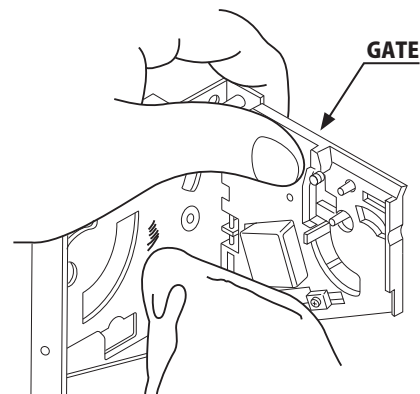

FIG. 12-1a

CLEANING THE COIN SELECTOR (MECHANICAL).

1 Remove and clean smears by using a soft cloth dipped in water or diluted chemical detergent and then squeezed dry.

2 Remove the CRADLE.. When removing the retaining ring (E ring) be very careful so as not to bend the rotary shaft.

3 Remove stain from the rotary shaft and shaft receiving portions by wiping off with a soft cloth, etc.

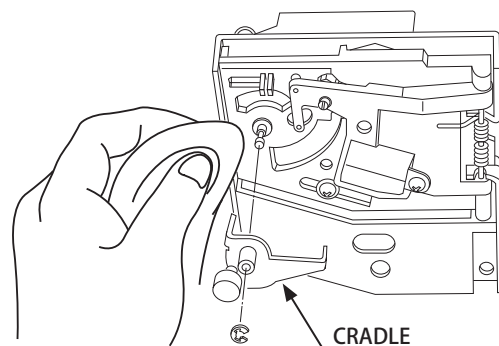

FIG. 12-1b

4 After wiping off as per previous step, further apply a dry cloth to completely dry the Coin Selector.

Coin Insertion Test

Once every month, when performing the Coin SW Test, simultaneously check the following:

Does the Coin Meter count satisfactorily?

Does the coin drop into the cashbox correctly?

Is the coin rejected when inserted while keeping the REJECT Button pressed down?

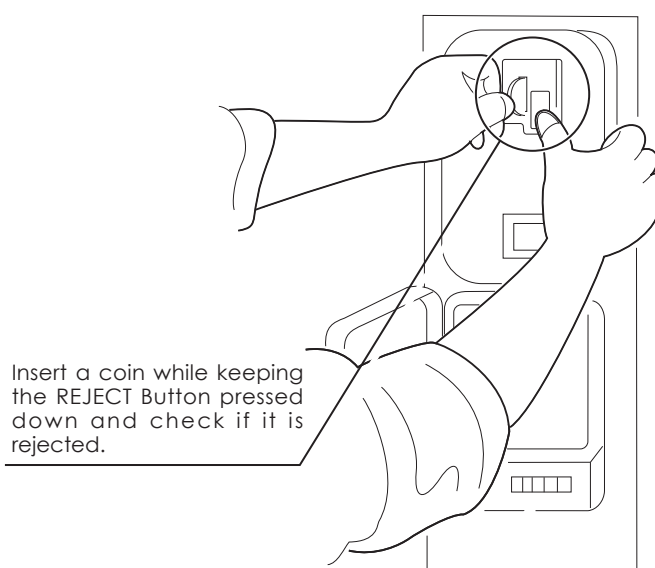

FIG. 12-1c

CLEANING THE COIN SELECTOR (SR3/NRI)

- 1 Remove and clean smears by using a damp soft cloth dipped in water. DO NOT use any diluted chemical detergent or cleansing agent as this will impair the workings of the component.

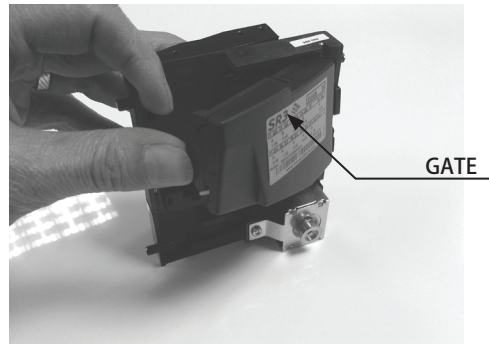

FIG. 12-1d

- 2 Open the reject gate to gain access to the rundown path.

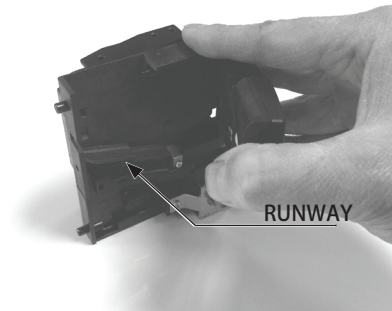

FIG. 12-1e

- 3 Remove the dirt and stains from the runway by wiping off with a soft damp cloth.

- 4 After wiping off as per previous step, further apply a dry cloth to completely dry the coin Selector.



FIG. 12-1f

Pictures for illustration purposes only..
Model shown is SR3 Coin validator. Visual differences
between models but process remain the same.

12-2 FAULT FINDING

Fault Finding

The following information is presented for customers' guidance in rectifying a fault but does not cover all possible causes.

All acceptors with electronic faults should be returned to an approved service centre for repair.

12

COIN HANDLING

| SYMPTOM | INVESTIGATE | POSSIBLE CAUSE |
|----------------------------------------------|-----------------------|------------------------------------------------------------|
| Acceptor does not work (all coins reject) | Connector | Poor Contact |
| | | Loose Wire |
| | Power Supply | Not switched on |
| | | Incorrect voltage |
| | | Inadequate current |
| | | Rise time too slow |
| | Inhibit all inputs | Acceptor Inhibited |
| | Accept gate | Gate not free or dislocated |
| | Accept channel | Obstruction |
| | Reject gate | Not fully closed |
| | LED on rear cover RED | EEPROM chksm error |
| SR Sensor fault | | |
| Credit opto fault | | |
| Credit sensor blocked | | |
| | Reject lever pressed | |
| LED on rear cover YELLOW | Reinstall power | |
| Poor Acceptance | Power Supply | Voltage less than 10v (Voltage drops when coil engages) |
| | Accept gate | Gate jam or dislocated |
| | Connector | Loose |
| | Coin rundown | Dirty |
| | Bank Select | Both banks enabled |
| Coin stick or jam in acceptor. | Accept channel | Acceptor dirty or may have some damage |
| | Accept gate | |
| | Reject gate | |
| A true coin type rejects | Label | Coin not programmed |
| No accept signal | Connector | Loose or broken wire |
| | Accept channel | Path dirty or obstructed |

12-3 ADJUSTING THE PRICE OF PLAY (EXCEL)

STOP IMPORTANT

• SEGA amusement products are fitted with either an EXCEL CREDIT PCB or a VTS (Volume, Test, Service) PCB. Both these components operate coin handling in the same way. Only one of these components are fitted.

• The price of play is determined by the configuration of switches located on either an EXCEL board or VTS board. The type of board used is determined by product location. Switch settings for both types of board remain the same.

This product comes equipped with a Money Controls SR3 Coin Acceptor. To adjust the price of play ALL credit settings are adjusted via the EXCEL CREDIT BOARD.

IMPORTANT!

The CREDIT SETTINGS within the SYSTEM TEST MODE must be set to 1 coin 1 credit to allow the CREDIT BOARD to function correctly.

The VTS BD has a built in Credit Board. This is controlled by 2 DIL Switches. These allow the operator to select the price of play, type of coin acceptor and region.

EXCEL Credit Board

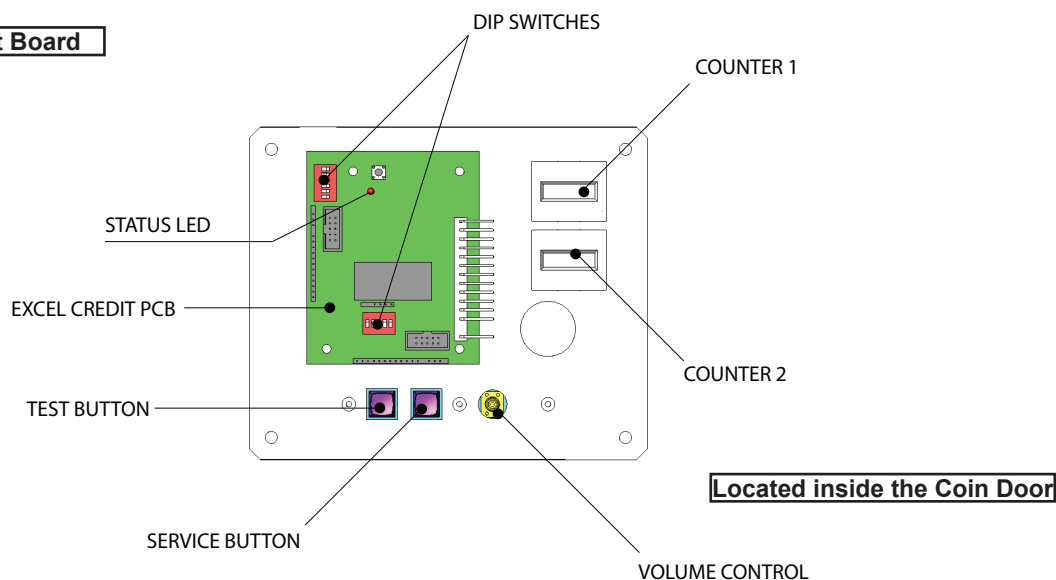

FIG. 12-3

DIL SW3 (Regional Settings)

Adjust these switches to specify the type of Coin Acceptor used and currency.

Default = SW1&SW2 ON - NRI in parallel mode, Sterling.

TEST BUTTON

Provides access to the TEST MENU when pressed.

SERVICE BUTTON

Provides a SERVICE CREDIT when pressed

Status LED

Flashes when functioning.

CHANNEL 1

To Coin Acceptor (SR3 TYPE.)

DIL SW1 (credit settings)

Adjust to required price of pay.

VOL CONTROL

MAIN VOLUME ADJUSTMENT (FRONT SPEAKERS)

12-4 ADJUSTING THE PRICE COMMON (USA)

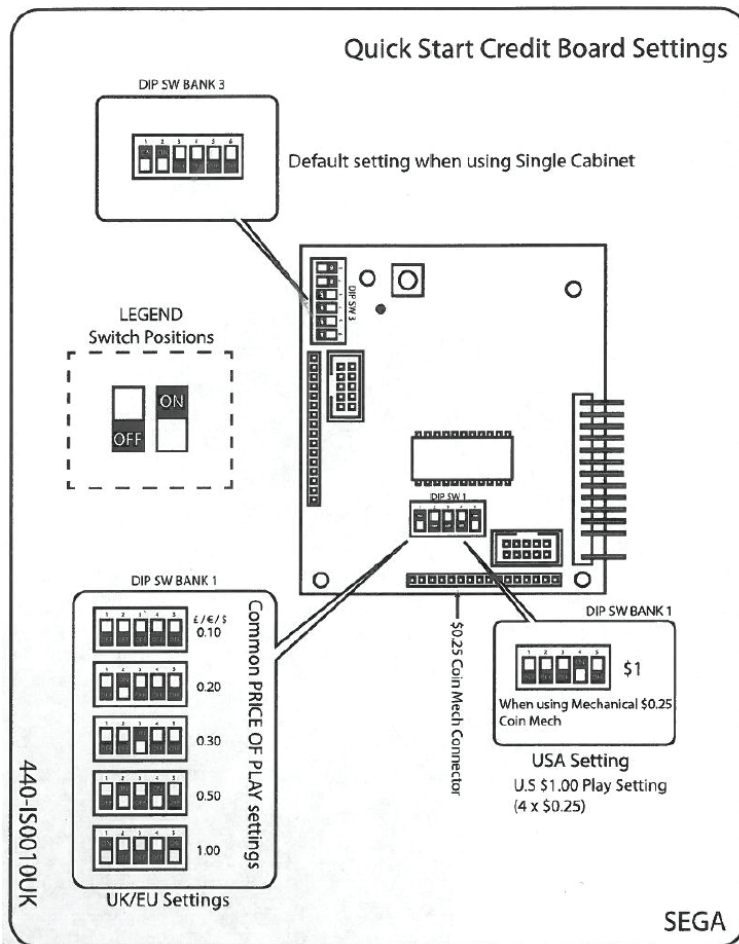

FIG. 12-4

| DIL SWITCH BANK ONE (5 way SW1) | | | | | | |
|---------------------------------|--------|-----|-----|-----|-----|-----|
| Item | Price | SW1 | SW2 | SW3 | SW4 | SW5 |
| 1 | 25cent | OFF | OFF | OFF | OFF | OFF |
| 3 | 50cent | OFF | ON | OFF | OFF | OFF |
| 5 | 75cent | OFF | OFF | ON | OFF | OFF |
| 9 | \$1.00 | OFF | OFF | OFF | ON | OFF |
| 16 | \$2.00 | ON | ON | ON | ON | OFF |
| | | | | | | |
| DIL SWITCH BANK TWO (6 way SW3) | | | | | | |
| Type | SW1 | SW2 | SW3 | SW4 | SW5 | SW6 |
| USA | OFF | OFF | OFF | OFF | OFF | OFF |

Table 1 12-4

QUICK VIEW SETTINGS

SEGA EXCEL CREDIT BOARD PRICE OF PLAY SETTINGS

| Play Price £ / € / \$ | Bonus adder | BANK 1 | | | | |
|-----------------------------|-----------------------------------------------|--------|-----|-----|-----|-----|
| | | 1 | 2 | 3 | 4 | 5 |
| 1 0.10 | No Bonus | OFF | OFF | OFF | OFF | OFF |
| 2 0.10 | 0.50 = 6 plays | ON | OFF | OFF | OFF | OFF |
| 3 0.20 | No Bonus | OFF | ON | OFF | OFF | OFF |
| 4 0.20 | 0.50 = 3 plays 1.00 = 6 plays 2.00 = 12 plays | ON | ON | OFF | OFF | OFF |
| 5 0.30 | No Bonus | OFF | OFF | ON | OFF | OFF |
| 6 0.30 | - 1.00 = 4 plays 2.00 = 8 plays | ON | OFF | ON | OFF | OFF |
| 7 0.30 | 0.50 = 2 plays 1.00 = 4 plays | OFF | ON | ON | OFF | OFF |
| 8 0.40 | No Bonus | OFF | OFF | OFF | ON | OFF |
| 8 0.40 | - 1.00 = 3 play 2.00 = 6 plays | ON | OFF | OFF | ON | OFF |
| 9 0.50 | No Bonus | OFF | ON | OFF | ON | OFF |
| 10 0.50 | - 1.00 = 3 plays 2.00 = 6 plays | ON | ON | OFF | ON | OFF |
| 11 0.50 | - 1.00 = 2 plays 2.00 = 5 plays | OFF | OFF | ON | ON | OFF |
| 12 0.60 | No Bonus | ON | OFF | ON | ON | OFF |
| 13 0.60 | - 1.00 = 2 plays 2.00 = 4 plays | OFF | ON | ON | ON | OFF |
| 14 0.80 | No Bonus | ON | ON | ON | ON | OFF |
| 15 0.80 | - 1.50 = 2 plays | OFF | OFF | OFF | OFF | ON |
| 16 1.00 | No Bonus | ON | OFF | OFF | OFF | ON |
| 17 1.00 | - - 2.00 = 3 plays | OFF | ON | OFF | OFF | ON |
| 18 1.00 | - 2.00 = 2 plays 4.00 = 5 plays | ON | ON | OFF | OFF | ON |
| 19 1.50 | No Bonus | OFF | OFF | ON | OFF | ON |
| 20 1.50 | - 2.00 = 2 plays | | | | | |
| 21 2.00 | No Bonus | OFF | ON | ON | OFF | ON |
| 22 2.00 | - - 5.00 = 3 plays | | | | | |
| 23 3.00 | No Bonus | OFF | OFF | OFF | ON | ON |
| 24 3.00 | - - 5.00 = 2 plays | ON | OFF | OFF | ON | ON |
| 25 5.00 | No Bonus | OFF | ON | OFF | ON | ON |
| 26 5.00 | - - 10.00 = 3 plays | ON | ON | OFF | ON | ON |
| 27 7.50 | No Bonus | OFF | OFF | ON | ON | ON |
| 28 7.50 | - - 10.00 = 2 plays | ON | OFF | ON | ON | ON |
| 29 10.00 | No Bonus | OFF | ON | ON | ON | ON |
| 30 FREE | Free Play | ON | ON | ON | ON | ON |

*All shaded areas are default price of play values with no additional bonuses

Table 2 12-4

| Country | | Setting | Switch 3 Setting | | | | | Credit Board Mode Settings Switch 3 | | | | | | | | | |
|---------------|-----------------------------|---------|------------------|-------|-------|----------|----------------|-------------------------------------|----------------------------|---------|-----------|-----------|-----------|---------------|--|--|--|
| | | | SW1 | SW2 | SW3 | SW4 | SW5 | SW6 | Coin Validator Programming | | | | | C120/SR3 Only | | | |
| | | | COIN1 | COIN2 | COIN3 | COIN4 | COIN5 | COIN6 | COIN7 | COIN8 | COIN9 | COIN10 | COIN11 | COIN12 | | | |
| UK | Coin Controls C220 Parallel | OFF | OFF | OFF | OFF | £1 | 50p new | 20p | 10p | - | 50p old | - | - | - | | | |
| UK | Coin Controls C220 Binary | ON | OFF | OFF | OFF | £1 | 50p new | 20p | 10p | - | 50p old | - | - | - | | | |
| UK | Coin Controls C220 Binary | OFF | ON | OFF | OFF | £1 | 50p new | 20p | 10p | - | £2 | - | - | - | | | |
| UK | Coin Controls SR3 Parallel | ON | ON | OFF | OFF | £1 | 50p new | 20p | 10p | - | £2 | - | - | - | | | |
| UK | Coin Controls SR3 Parallel | OFF | OFF | ON | OFF | £2 | £1 | 50p new | 20p | 20p | 10p | - | - | - | | | |
| Euro | Coin Controls SR3 Parallel | OFF | OFF | ON | OFF | €2 | €1 | 50p new | 20p | 20p | 10p | - | - | - | | | |
| UK | Mars ME/MS 111 Parallel | ON | OFF | ON | OFF | £1 | £2 | 20p | 10p | 50p new | 50p old | - | - | - | | | |
| UK | NRI Parallel | OFF | ON | ON | OFF | 10p | 20p | 50p | £1 | £2 | - | - | - | - | | | |
| Belgium | Parallel | ON | ON | ON | OFF | - | 50Bfr | 20Bfr | 5Bfr | - | - | - | - | - | | | |
| Holland | Parallel | OFF | OFF | OFF | ON | - | 5NLG | 2.5NLG | 1NLG | - | - | - | - | - | | | |
| Austria | SR3 Parallel | ON | OFF | OFF | ON | 20Sch | 10Sch | 5Sch | 1Sch | - | - | - | - | - | | | |
| Spain | Coin Controls C220 Binary | OFF | ON | OFF | ON | 500Pta | 200Pta | 100Pta | 50Pta | 25Pta | 200Pt old | 50Pta old | 25Pta old | - | | | |
| Spain | SR3/NRI Parallel | ON | ON | OFF | ON | 500Pta | 200Pta | 100Pta | 50Pta | 25Pta | 25Pta | 50Pta old | 25Pta old | - | | | |
| Spain | Coin Controls C220 Parallel | OFF | OFF | ON | ON | 100Pta | 50Pta new | - | 25Pta new | - | 50Pta old | - | 25Pta old | - | | | |
| Portugal Euro | Parallel | ON | OFF | ON | ON | 200Es €1 | 100Es 50¢ | 50Es | - | - | - | - | - | - | | | |
| | TBA | | | | OFF | TBA | | | | | | | | | | | |
| | | | | | | | | | | | | | | | | | |
| | Channels | | | | ON | TBA | | | | | | | | | | | |
| | | | | | | OFF | Direct Mode | | | | | | | | | | |
| | | | | | | ON | 2 channel Mode | | | | | | | | | | |

Please Note
The credit board automatically sets the validator for parallel and binary operation through an output on pin 8 of the 17 way pinstrip. For the feature to work it is necessary for the validator interconnecting cable to include at wire at this position

Note: These switch settings are under constant review and may change due to world currency updates.

Set SW 1 according to the option settings found in the relevant Price of Play Settings Table on the following pages.

Set SW 3 on the VTS /Excel board as shown in the table above corresponding to the country required.

Table 3 12-4

| | Price | Bonus | DIL Switch 1 | | | | |
|----|-------|----------------------------------------------------|--------------|-----|-----|-----|-----|
| | | | 1 | 2 | 3 | 4 | 5 |
| 1 | 10p | 50p = 5 plays | OFF | OFF | OFF | OFF | OFF |
| 2 | 10p | 50p = 6 plays @ 8.33p per play | ON | OFF | OFF | OFF | OFF |
| 3 | 20p | 50p = 2.5 plays 50p = 3 plays @ 16.66p per play | OFF | ON | OFF | OFF | OFF |
| 4 | 20p | 50p = 3 plays @ 16.66p per play | ON | ON | OFF | OFF | OFF |
| 5 | 30p | 50p = 1.66 plays 50p = 1.66 plays | OFF | OFF | ON | OFF | OFF |
| 6 | 30p | 50p = 1.66 plays | ON | OFF | ON | OFF | OFF |
| 7 | 30p | 50p = 2 plays @ 25p per play | OFF | ON | ON | OFF | OFF |
| 8 | 30p | 50p = 2 plays @ 25p per play | ON | ON | ON | OFF | OFF |
| 9 | 40p | 50p = 1.25 plays 50p = 1.25 plays | OFF | OFF | OFF | ON | OFF |
| 10 | 40p | 50p = 1.25 plays | ON | OFF | OFF | ON | OFF |
| 11 | 50p | 50p = 1 play 50p = 1 play | OFF | ON | OFF | ON | OFF |
| 12 | 50p | 50p = 1 play | ON | ON | OFF | ON | OFF |
| 13 | 50p | 50p = 1 play | OFF | OFF | ON | ON | OFF |
| 14 | 60p | 50p = 0.83 play 50p = 0.83 play | ON | OFF | ON | ON | OFF |
| 15 | 60p | 50p = 0.83 play | OFF | ON | ON | ON | OFF |
| 16 | 80p | 50p = 0.62 play 50p = 0.62 play | ON | ON | ON | ON | OFF |
| 17 | 80p | 50p = 0.62 play | OFF | OFF | OFF | OFF | ON |
| 18 | £1 | 2x50p = 1 play 2x50p = 1 play | ON | OFF | OFF | OFF | ON |
| 19 | £1 | 2x50p = 1 play | OFF | ON | OFF | OFF | ON |
| 20 | £1 | 2x50p = 1 play | ON | ON | OFF | OFF | ON |
| 21 | £1.50 | 3x50p = 1 play 3x50p = 1 play | OFF | OFF | ON | OFF | ON |
| 22 | £1.50 | 3x50p = 1 play | ON | OFF | ON | OFF | ON |
| 23 | £2 | 4x50p = 1 play 4x50p = 1 play | OFF | ON | ON | OFF | ON |
| 24 | £2 | 4x50p = 1 play | ON | ON | ON | OFF | ON |
| 25 | £3 | 6x50p = 1 play 6x50p = 1 play | OFF | OFF | OFF | ON | ON |
| 26 | £3 | 6x50p = 1 play | ON | OFF | OFF | ON | ON |
| 27 | £5 | £1 = 0.2 play £1 = 0.2 play | OFF | ON | OFF | ON | ON |
| 28 | £5 | £1 = 0.2 play | ON | ON | OFF | ON | ON |
| 29 | £7.50 | £5 = 0.66 play £5 = 0.66 play | OFF | OFF | ON | ON | ON |
| 30 | £7.50 | £5 = 0.66 play | ON | OFF | ON | ON | ON |
| 31 | £10 | £10 = 1 play £10 = 1 play | OFF | ON | ON | ON | ON |
| 32 | | Free Play | ON | ON | ON | ON | ON |

Table 4 12-4

STERLING PRICE OF PLAY SETTINGS (SW1)

| | Price | Bonus | | | | DIL Switch 1 | | | | |
|----|-------|---------------------------------|--------------------------------|---------------------------------|-----|--------------|-----|-----|-----|-----|
| | | | | | | 1 | 2 | 3 | 4 | 5 |
| 1 | 10¢ | 50¢ = 5 plays | €1 = 10 plays | €2 = 20 plays | OFF | OFF | OFF | OFF | OFF | OFF |
| 2 | 10¢ | 50¢ = 6 plays @ 8.33p per play | €1 = 12 plays @ 8.33¢ per play | €2 = 24 plays @ 8.33¢ per play | ON | OFF | OFF | OFF | OFF | OFF |
| 3 | 20¢ | 50¢ = 2.5 plays | €1 = 5 plays | €2 = 10 plays | OFF | ON | OFF | OFF | OFF | OFF |
| 4 | 20¢ | 50¢ = 3 plays @ 16.66¢ per play | €1 = 6 plays @ 16.66¢ per play | €2 = 12 plays @ 16.66¢ per play | ON | ON | OFF | OFF | OFF | OFF |
| 5 | 30¢ | 50¢ = 1.66 plays | €1 = 3.33 plays | €2 = 6.66 plays | OFF | OFF | ON | OFF | OFF | OFF |
| 6 | 30¢ | 50¢ = 1.66 plays | €1 = 4 plays @ 25¢ per play | €2 = 8 plays @ 25¢ per play | ON | OFF | ON | OFF | OFF | OFF |
| 7 | 30¢ | 50¢ = 2 plays @ 25¢ per play | €1 = 4 plays @ 25¢ per play | €2 = 8 plays @ 25¢ per play | OFF | ON | ON | OFF | OFF | OFF |
| 8 | 30¢ | 50¢ = 2 plays @ 25¢ per play | €1 = 3 plays @ 33.33¢ per play | €2 = 6 plays @ 33.33¢ per play | ON | ON | ON | OFF | OFF | OFF |
| 9 | 40¢ | 50¢ = 1.25 plays | €1 = 2.5 plays | €2 = 5 plays | OFF | OFF | OFF | ON | OFF | OFF |
| 10 | 40¢ | 50¢ = 1.25 plays | €1 = 3 plays @ 33.33¢ per play | €2 = 6 plays @ 33.33¢ per play | ON | OFF | OFF | OFF | ON | OFF |
| 11 | 50¢ | 50¢ = 1 play | €1 = 2 plays | €2 = 4 plays | OFF | ON | OFF | ON | OFF | OFF |
| 12 | 50¢ | 50¢ = 1 play | €1 = 3 plays @ 33.33¢ per play | €2 = 6 plays @ 33.33¢ per play | ON | OFF | OFF | ON | OFF | OFF |
| 13 | 50¢ | 50¢ = 1 play | €1 = 2 plays | €2 = 5 plays @ 40¢ per play | OFF | OFF | ON | ON | OFF | OFF |
| 14 | 60¢ | 50¢ = 0.83 play | €1 = 1.66 plays | €2 = 3.33 plays | ON | OFF | ON | ON | OFF | OFF |
| 15 | 60¢ | 50¢ = 0.83 play | €1 = 2 plays @ 50¢ per play | €2 = 4 plays @ 50¢ per play | OFF | ON | ON | ON | ON | OFF |
| 16 | 80¢ | 50¢ = 0.62 play | €1 = 1.25 plays | €2 = 2.5 plays | ON | ON | ON | ON | ON | OFF |
| 17 | 80¢ | £1 = 1.25 plays | €1.50 = 2 plays @ 75¢ per play | €2 = 2.5 plays | OFF | OFF | OFF | OFF | OFF | ON |
| 18 | €1 | 2x50¢ = 1 play | €1 = 1 play | €2 = 2 plays | ON | OFF | OFF | OFF | OFF | ON |
| 19 | €1 | 2x50¢ = 1 play | €1 = 1 play | €2 = 3 plays @ 66.6¢ per play | OFF | ON | OFF | OFF | OFF | ON |
| 20 | €1 | 2x50¢ = 1 play | €2 = 2 plays | €4 = 5 plays @ 80¢ per play | ON | ON | OFF | OFF | OFF | ON |
| 21 | €1.50 | 3x50¢ = 1 play | €1 = 0.66 plays | €3 = 2 plays | OFF | OFF | ON | OFF | OFF | ON |
| 22 | €1.50 | 3x 50¢ = 1 play | €1 = 0.66 plays | €2 = 2 plays @ €1 per play | ON | OFF | ON | OFF | OFF | ON |
| 23 | €2 | 4x 50¢ = 1 play | €1 = 0.5 play | €2 = 1 play | OFF | ON | ON | OFF | OFF | ON |
| 24 | €2 | 4x 50¢ = 1 play | €1 = 0.5 play | €5 = 3 plays @ €1.66 per play | ON | ON | ON | OFF | OFF | ON |
| 25 | €3 | 6x50¢ = 1 play | €1.50 = 0.5 play | €3 = 1 play | OFF | OFF | OFF | ON | ON | ON |
| 26 | €3 | 6x50¢ = 1 play | €1.50 = 0.5 play | €5 = 2 plays @ €2.50 per play | ON | OFF | OFF | OFF | OFF | ON |
| 27 | €5 | €1 = 0.2 play | €5 = 1 play | €10 = 2 plays | OFF | ON | OFF | ON | ON | ON |
| 28 | €5 | €1 = 0.2 play | €5 = 1 play | €10 = 3 plays @ 3.33¢ per play | ON | ON | OFF | OFF | OFF | ON |
| 29 | €7.50 | €5 = 0.66 play | €10 = 1.33 plays | €15 = 2 plays | OFF | OFF | ON | ON | ON | ON |
| 30 | €7.50 | €5 = 0.66 play | €10 = 1.33 plays | €10 = 2 plays @ €5 per play | ON | OFF | ON | ON | ON | ON |
| 31 | €10 | €10 = 1 play | €20 = 2 play | €30 = 3 play | OFF | ON | ON | ON | ON | ON |
| 32 | | Free Play | | | | ON | ON | ON | ON | ON |

Table 5 12-4

13 REPLACING INCANDESCENT LAMPS

⚠ WARNING

- When working with the product, be sure to turn the power off. Working with the power on may cause an electric shock or short circuit.
- You may get burned by a hot fluorescent lamp or other lamps. Pay full attention to the lamps when performing the work.
- Be sure to use lamps of the designated rating. Using lamps of undesignated rating can cause a fire or malfunctioning.
- There is the danger of short circuits or smoke generation due to deterioration of insulation in lighting fixtures resulting from age deterioration. Check for anomalies such as the following: Does it smell like something is burning? Is there socket discoloration? Are any lamps being replaced frequently? Do lamps not go on properly?

⚠ CAUTION

The Coin Door Lamp utilises a 12v 1.2w Wedge Bulb. It is important that you replace this bulb or any other bulb of that of the same voltage and rating. Failing to observe this caution may result in PCB failure or possible fire hazard.

13-1 COIN DOOR LAMP

Step 1. Open the Coin Door and locate the Lamp Housing directly behind the Coin Insert Bezel.

Lamp Housing

Step 2. Hold the Lamp Housing firmly between your index finger and thumb and gently pull upwards. Do Not try to remove the Lamp Housing whilst holding the bulb as the bulb may break causing injury.

Step 3. Once the Lamp Housing has been removed, carefully hold the bulb between your fingers and pull the Lamp Housing away.

Do not twist either bulb or Lamp Housing whilst removing the bulb as this may cause damage to both bulb and or Housing.

Type: Wedge Bulb - 12v, 1.2w

Step 4. Simply push-fit a replacement bulb of the same type and follow these steps in reverse to refit.

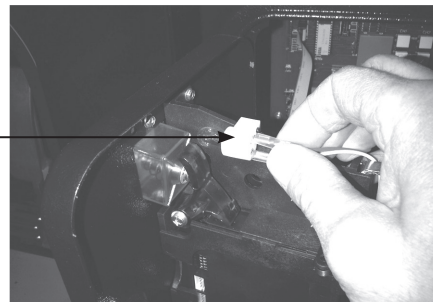

FIG. 13-1a



FIG. 13-1b

13-2 MOTION STOP LAMP

- 1 Turn off the power.
- 2 Remove the (4) M4x16 SECURITY TRX from the START/VIEW Button Panel.

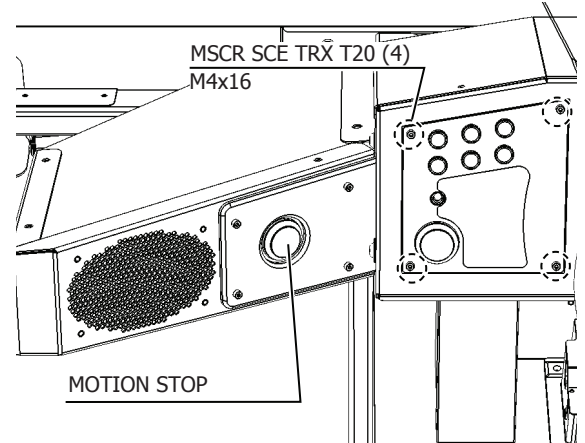

FIG. 13-2a

- 3 Remove the START/VIEW button panel and locate the (1) M6x20 HEX BLT BLK positioned on the inside left wall. Remove the Bolt.

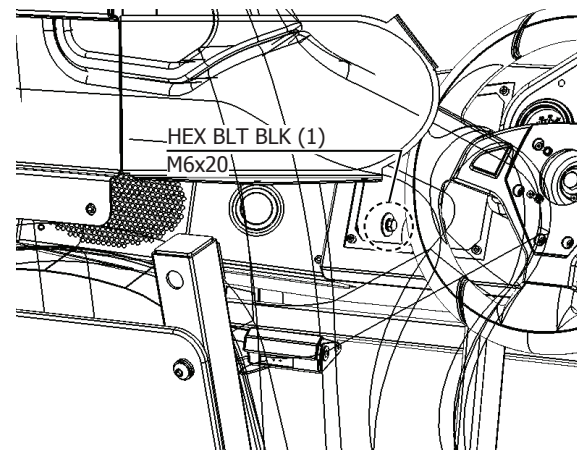

FIG. 13-2b

- 4 Remove the (4) M4x16 BT HD SKT Screws from the Speaker Panel.

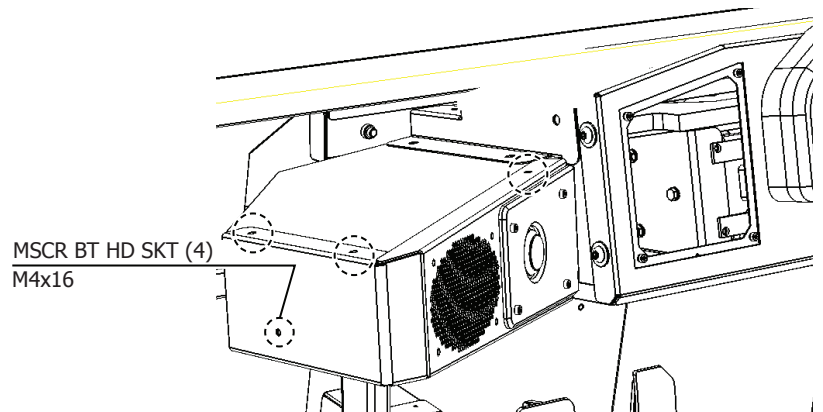

FIG. 13-2c

- 5** Carefully pull the Speaker and Button Panel away from the housing. Taking care not to pull at the wires connected to the speaker and button assy on the reverse side.

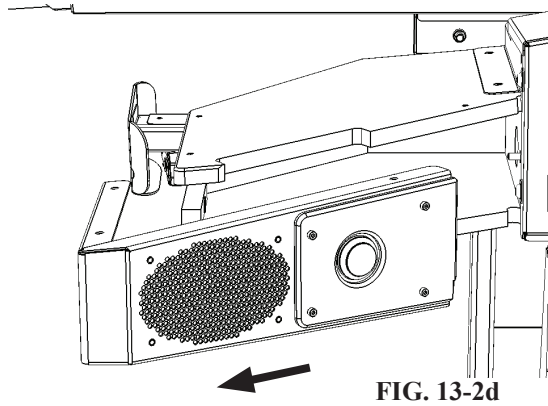

FIG. 13-2d

- 6** Remove Lamp and Switch housing from the Button by pulling the housing away from the button. These can sometimes be a little tight on initial removal.

LAMP AND SWITCH HOUSING

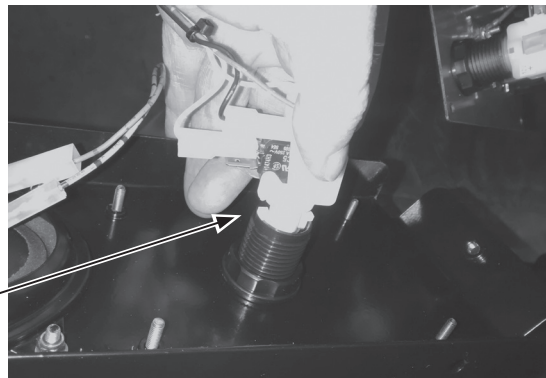

FIG. 13-2e

- 7** Replace the bulb for that of the same type. Place the bulb and switch housing back into the button assembly and reassemble the control panel. To reassemble, simply follow steps 1 to 5 in reverse order,

BULB WEDGE TYPE
12v 1.2W

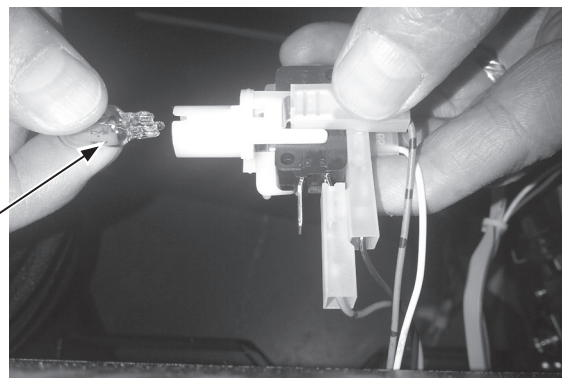

FIG. 13-2f

14 PERIODIC INSPECTION

WARNING

- Once a year, check to see if power cords are damaged, the plug is securely inserted, dust is accumulated between the socket outlet and the power plug, etc. Using the product with accumulated dust in the interior may cause fire or electric shock.
- Never use a water jet, etc. to clean the inside and outside of the cabinet. If wetness occurs for any reason, do not use the product until it has completely dried.
- Once a year, request the office shown on this manual or the dealer from whom the product was originally purchased to perform the internal cleaning. Using the product with accumulated dust in the interior may cause fire or other accidents. Note that you are liable for the cost of cleaning the interior parts.
- There is the danger of accidents involving electrical short circuits or fire caused by factors such as the deterioration of insulation in electrical and electronic equipment over time. Check that there are no abnormalities such as odors from burning.

STOP IMPORTANT

The interior of the cabinet is hard to see from the outside which may lead to willful misconduct by players or accidents going unnoticed. When the game is not in use, check the interior at regular intervals and make sure that nothing has been forgotten or placed on the seats.

CAUTION

- Be careful not to get your fingers caught when opening/closing or attaching/removing doors, lids and other such parts.
- When working inside the cabinet, you could get caught on parts or scratch yourself on them. Check the inside of the cabinet and be aware of where the parts are before performing the work.

The items listed below require periodic checks and maintenance to guarantee the performance of this machine and to ensure safe operation.

Regularly clean all points of direct player contact such as the steering wheel and seat. Make regular inspections to ensure there is no damage to the surfaces and there are no foreign objects on the parts.

TABLE 14 PERIODIC INSPECTION TABLE

| ITEMS | DESCRIPTION | PERIOD |
|-----------------------------|------------------------------------------------|---------------------------|
| CABINET | Confirm that adjusters contact floor | Daily |
| | Seat check, removal of forgotten / other items | Daily |
| LCD DISPLAY | Screen cleaning | Weekly |
| | Check screen adjustment | 1 month |
| | Exchange of lamp unit | When message is displayed |
| CONTROL UNIT | Cleaning | As appropriate |
| | Potentiometer Inspection | 1 month |
| | Greasing | 3 months |
| SEAT MECH | Cleaning | As appropriate |
| | Check for loose fixings | 3 months |
| | Greasing | 3 months |
| ACCEL/BRAKE | Potentiometer Inspection | 1 month |
| | Greasing | 3 months |
| COIN SELECTOR | Inspection of coin switch | 1 month |
| | Coin insertion test | 1 month |
| | Coin Selector cleaning | 3 months |
| GAME BOARD | Individual tests | 1 month |
| | Check of settings | 1 month |
| LAMPS AND LIGHTING | Inspection of lighting fixtures | As appropriate |
| ELECTRICAL/ELECTRONIC PARTS | Inspection | As appropriate |
| POWER CABLE | Inspection, Cleaning | 1 year |
| CABINET INTERIOR | Cleaning | 1 year |
| CABINET SURFACES | Cleaning | As appropriate |

Cleaning the Cabinet Surfaces

When the cabinet surfaces become dirty, remove stains with a soft cloth soaked in water or diluted (with water) chemical detergent and then wrung dry. To avoid damaging the finish, do not use such solvents as thinner, benzene, etc. (other than ethyl alcohol) or abrasives (bleaching agent and chemical dust-cloth).

Some general-purpose household, kitchen, and furniture cleaning products may contain strong solvents that degrade plastic parts, coatings, and print. Before using any cleaning product, read the product's cautionary notes carefully and test the product first on a small area that is not highly visible.

14-1 CLEANING SENSORS AND GREASING SEAT RAILS

CLEANG THE FLOOR SENSORS

When in operation for sometime, it is possible for the Safety Sensors to become dusty. Periodic inspection of these sensors are essential to maintain a safe operation.

To clean the sensors and the sensor reflector plates it is advised that an aerosol duster is used to remove any surface dust. Using a cloth and/or cleaning fluid may impair operation.

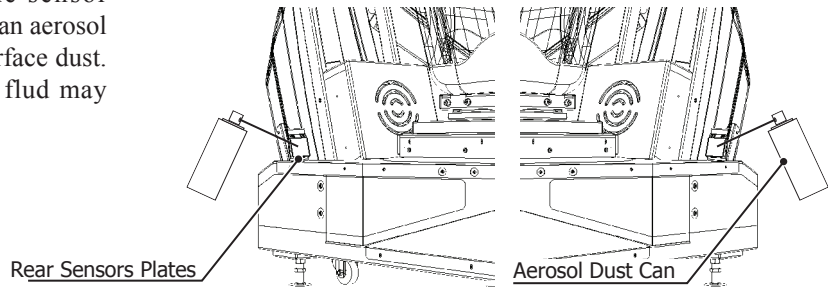

14-1 FIG.01

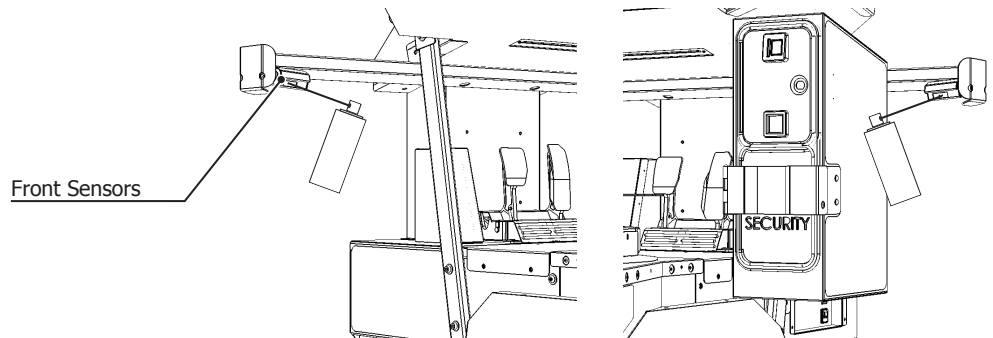

14-2 FIG.02

14-2 CLEANING SENSORS AND GREASING SEAT RAILS

GREASING SEAT RAIL

Move the seat to the rearmost position and apply grease to the portion shown in the figure once every 3 months by using NOK KLUBER L60 or GREASE MATE SEGA PART No. 090-0066. After greasing, move the seat a few times forward and backward so as to allow the grease to be applied all over uniformly.

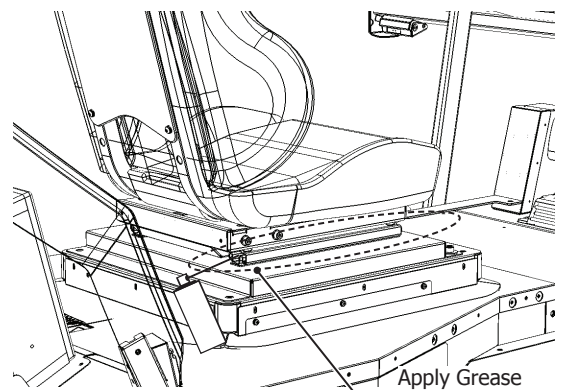

15 TROUBLESHOOTING & ERROR CODES

WARNING

- If an error message is displayed, have the problem looked at by a store maintenance person or a technician. Unless the problem is addressed by someone with specialized knowledge or skills, there could be electrical shock, short circuits or fire. If there are no store maintenance people or technicians, cut off the power immediately and contact the office shown in this manual or the dealer from whom the product was originally purchased.
- If problems other than those covered in this manual arise, or if no improvements can be noted after measures given in this manual have been taken, do not take measures indiscriminately. Cut off the power immediately and contact the office shown in this manual or the dealer from whom the product was originally purchased. Indiscriminate countermeasures could lead to unforeseeable accidents. They could also result in permanent damages.
- When working with the product, be sure to turn the power off. Working with the power on may cause an electric shock or short circuit.
- Be careful not to damage the wires. Damaged wires may cause an electric shock, short circuit or present a risk of fire.
- After the cause of circuit protector activation has been removed, have the circuit protector re-engaged. If the unit is used continuously as is, there could be heat generation or fire, depending on the cause of the activation.

CAUTION

- When removing and replacing parts, take due care not to trap or pinch your fingers.
- The Control Units contain gears, cams and other moving machine parts. Take due care not to trap or pinch your fingers.

 STOP

IMPORTANT

- Please refer to Chapter 9 of this manual for ERROR CODES.

15

TROUBLESHOOTING & ERROR CODES

TABLE 15 TROUBLESHOOTING TABLE

| PROBLEMS | CAUSE | COUNTERMEASURES |
|---------------------------------------------------------------|---------------------------------------------------------------------------------------------------------------------------------------------------|--------------------------------------------------------------------------------------------------------------------------------------------|
| When the main SW is turned ON, the machine is not activated. | The power is not ON. | Firmly insert the plug into the outlet. |
| | Incorrect power source/voltage. | Make sure that the power supply/voltage are correct. |
| | The Circuit Protector of the AC Unit functioned due to momentary overcurrent. | After eliminating the cause of overload, have the Circuit Protector of the AC Unit restored. (See Section 6 [11], refer to the following.) |
| | The screen is not adjusted correctly. | Adjust the screen correctly. (See chapter 10.) |
| No sound output. | Volume is not adjusted properly. | Adjust the volume. (See chapter 9.) |
| | Board or amp malfunction. | Check by performing a speaker test. (See 9.) |
| The Control Unit (Steering wheel) does not operate correctly. | Due to external or environmental factors the targeting is off. | Perform calibration in TEST Mode. (See 9.) |
| | Volume damaged. | Exchange the volume. (See 11.) |
| The Boost buttons do not operating properly. | Microswitches damaged. | Check ON, OFF on the input test and if it is not working exchange the microswitch. (See 11) |
| | Something is trapped or caught in the revolving or other parts. | Remove the trapped items / clean switch optics. |
| | Grease has deteriorated. | Apply grease to the designated grease areas. (See 11.) |
| Control Unit does not respond. | The Control Unit motor is set not to move. | Alter the TEST Mode settings. (See 9.) |
| | Due to overload or other factors, an error has occurred with the motor, which has been sensed by the motor sensor and the motor has been stopped. | Remove the cause of the motor error. |
| | Motor damaged. | Exchange the motor. |
| The Control Unit makes a lot of noise when it vibrates. | Due to a problem with the vibration parts or wear over time, the internal parts have moved. | Adjust the position of the vibration parts. |
| The START switch does not operate | Faulty switch or bad connections | Check the connections on the rear of the switch. If connections are good, replace switch. |

16 GAME BOARD

WARNING

- When working with the product, be sure to turn the power off. Working with the power on may cause an electric shock or short circuit.
- Be careful not to damage the wires. Damaged wires may cause electric shock or short circuit or present a fire risk.
- Do not expose the game board, etc. without a good reason. Failure to observe this can cause electric shock hazard or malfunctioning.
- Do not use this product with connectors other than those that were connected and used with the game board at the time of shipping. Do not carelessly connect wires to connectors that were not used at the time of shipping, as this may cause overheating, smoke or fire damage.
- When returning the game board after making repairs or replacements, make sure that there are no errors in the connection of connectors. Erroneous connections can lead to electrical shock, short circuits or fires.
- When connecting a connector, check the direction carefully. Connectors must be connected in only one direction. If indiscriminate loads are applied in making connections, the connector or its terminal fixtures could be damaged, resulting in electrical shock, short circuits or fires.

CAUTION

- In this product, setting changes are made during the test mode. The game board need not be operated. Use the game board, etc. as is with the same setting made at the time of shipment so as not to cause electric shock and malfunctioning.
- Static electricity from your body may damage some electronics devices on the IC board. Before handling the IC board, touch a grounded metallic surface so that the static electricity can be discharged.

STOP IMPORTANT

- When a game board is to be replaced, put the old game board with anomaly into a special box for replacing the game board and send it. If a special box is not available or if it has been damaged, arrange to have the Game Board packed in suitable packaging.
- For replacement or repair, pack the game board and send it without disassembling it. Order for servicing might not be accepted if any part of the game board has been removed. If any part is removed, a service fee will be charged even if the warranty period has not yet expired.
- Do not remove the key chip from the game board before sending the board for servicing.

16-1 HOW TO REMOVE GAME BOARD

The game board located at the rear of the cabinet behind the screen. Each car has its own Game Board.

- 1 Turn off the power.

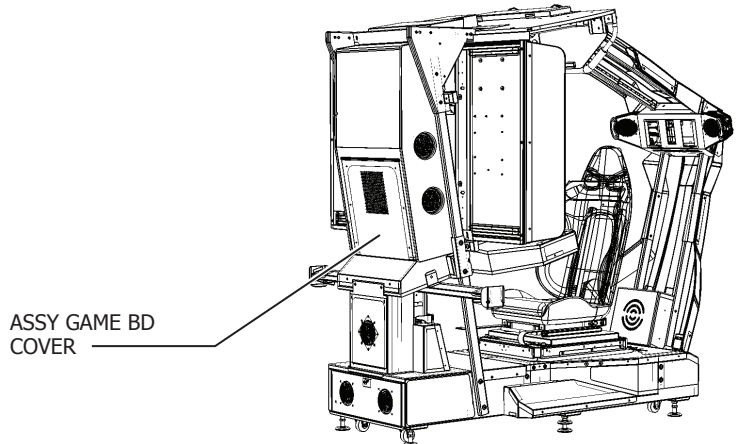

- 3 Remove both REAR and SIDE PANELS by unscrewing the (4) M4x16 BUTTON HEAD SOCKET SCREWS from both panels as shown.

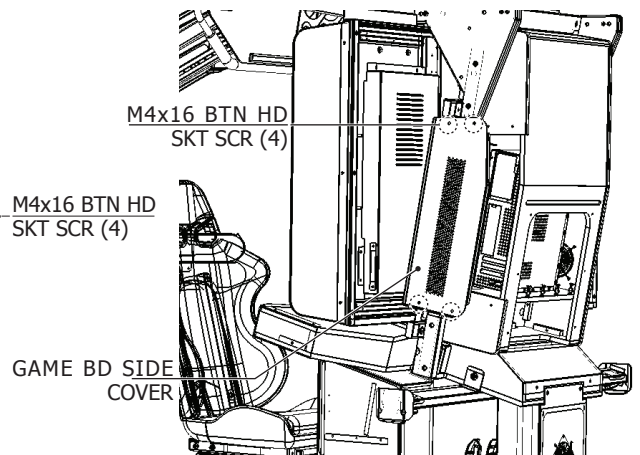
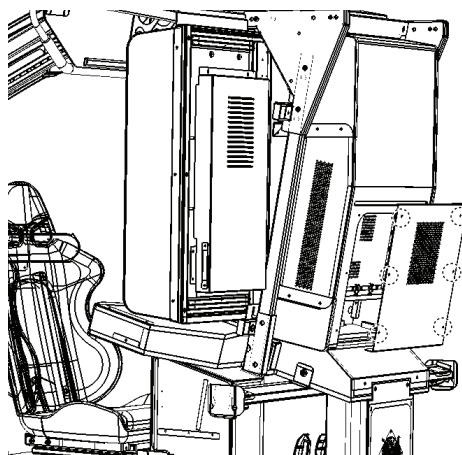

- 4 Carefully disconnect all of the connectors connected to the Game Bd. Unscrew the (2) M4x12 MCSR PH PAS which secure the GAME BD. Slide the GAME BD to the left and remove as shown in FIG. 16-1e

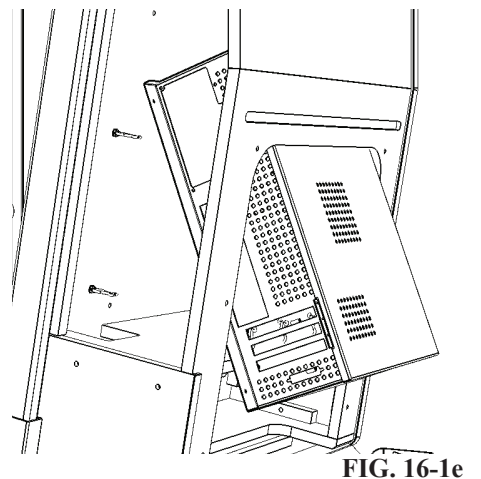
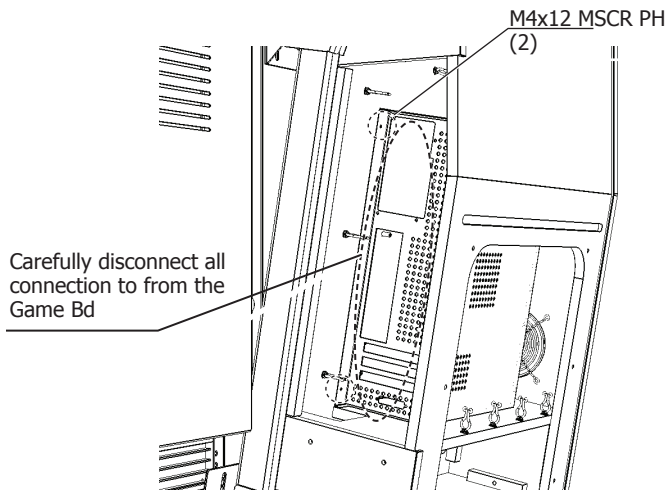

17 DESIGN RELATED PARTS

For the warning display stickers, refer to Section 1.



18 PARTS LIST

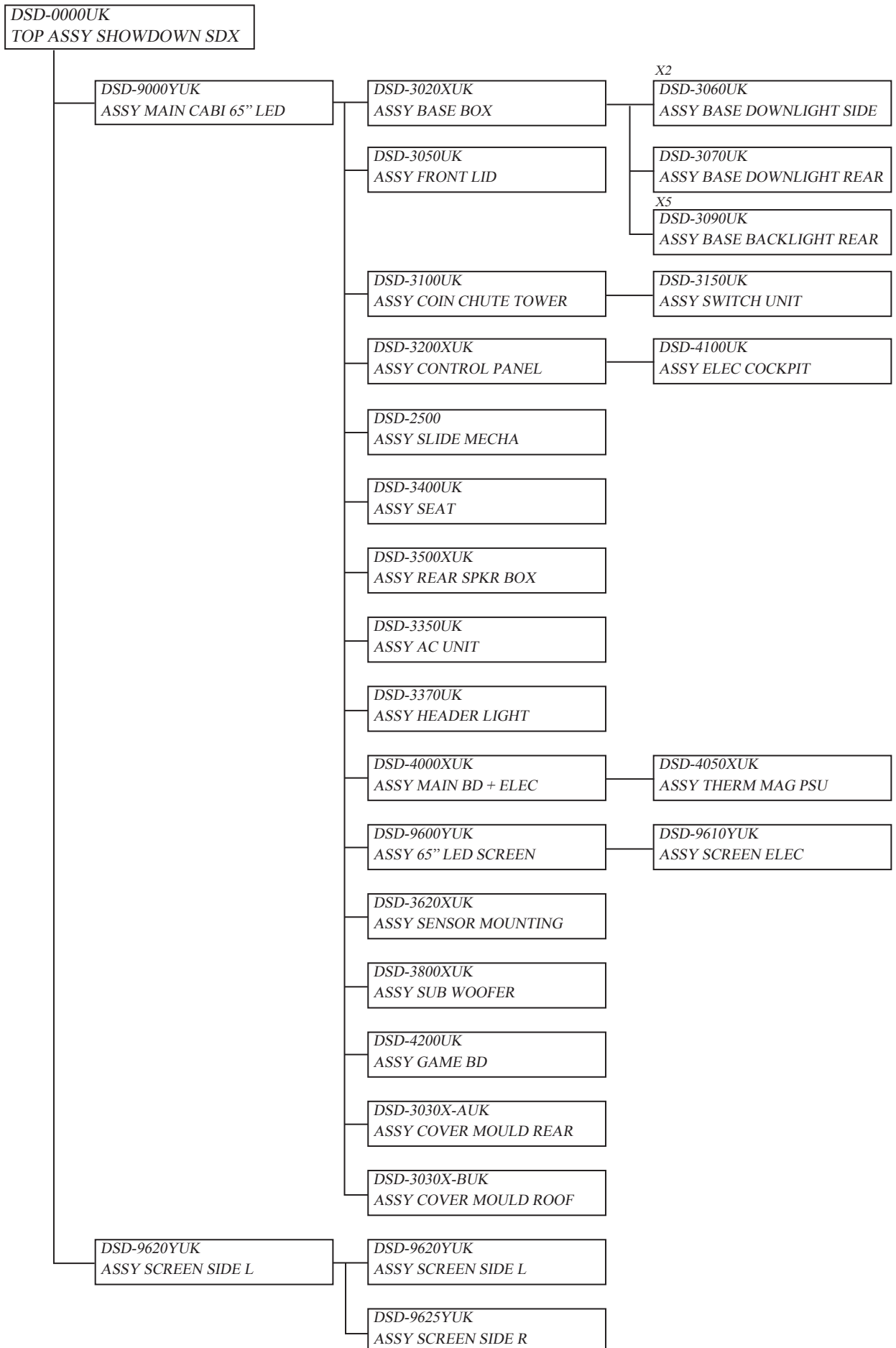

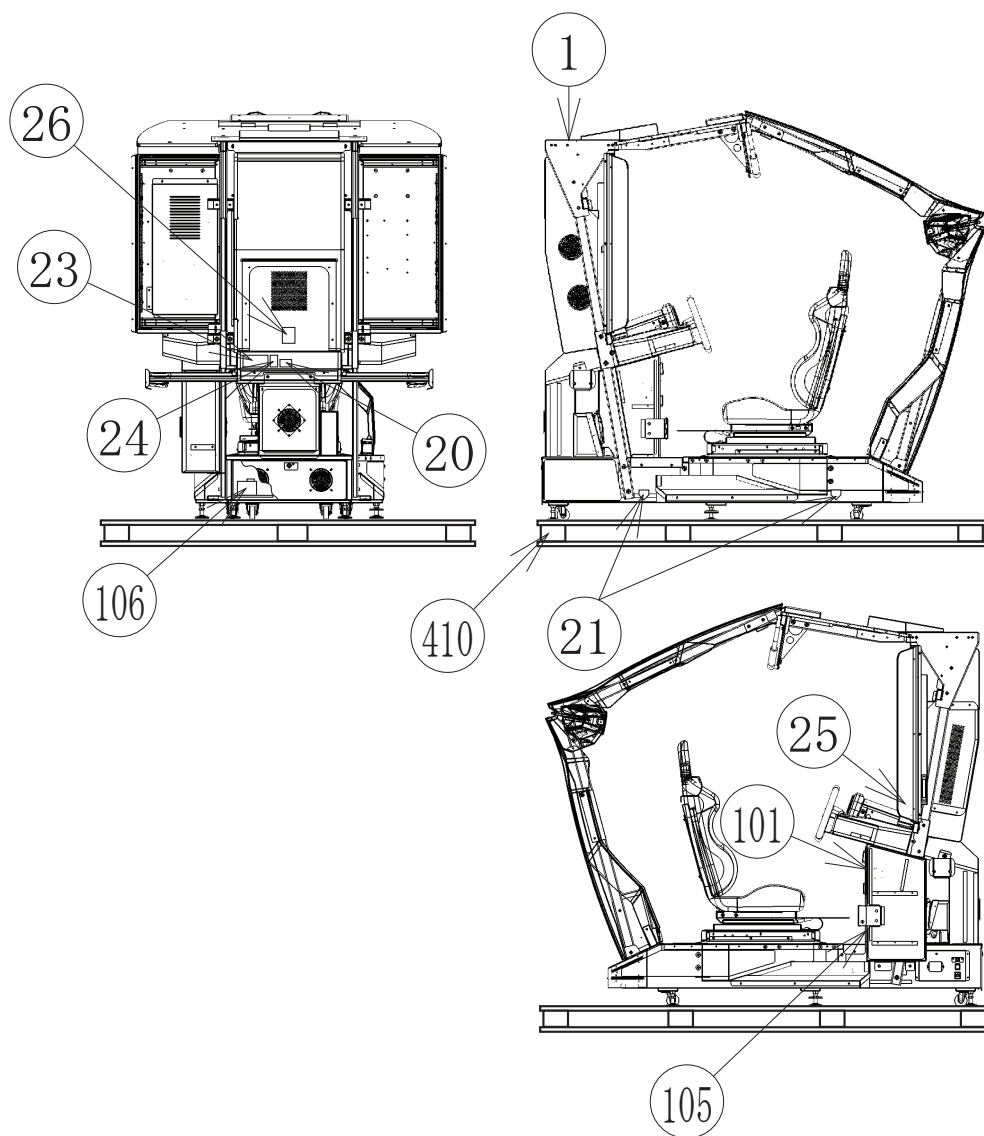

① TOP ASSY SHOWDOWN SDX (DSD-0000UK)

(D-2/2)

ITEM NO PART NO DESCRIPTION QTY

| | | | | |
|------|------------------|-------------------------------------|----------------------------------|---|
| *1 | DSD-9000YUK | ASSY MAIN CABI 65" LED | | 1 |
| *20 | 421-7988-91UK | STICKER SERIAL NUMBER UK | | 2 |
| *21 | 440-WS0100UK | LABEL WARNING FORK HERE | | 4 |
| *22 | 440-DS0010UK | LABEL DANGER HI VOLT | MON-1, GAMEBD-1, BACK DOORS-2 | 4 |
| *23 | LB1046 | LABEL TESTED FOR ELEC. SAFETY | | 1 |
| *24 | LB1130 | LABEL WEEE WHEELIE BIN | | 1 |
| *25 | 440-CS0186-01UK | STICKER CAUTION EPILEPSY | | 2 |
| *26 | 440-CS0010UK | LABEL CAUTION GENERIC | MON-1, COIN DOOR-1 | 2 |
| *101 | 220-5374-01 | DOOR DFMD W/FR&LOCK C120 UNIV | EUROPE SPEC. | 1 |
| *102 | 220-5575UK | LOCK (J9117) KEY TO LIKE 22MM W CAM | coin door | 1 |
| *103 | OS1247 | ALUMINIUM STICKY CLIP ASK-3 | | 3 |
| *104 | 220-5610-01 | SR3 STD BODYBSR3INGB | | 1 |
| *105 | 220-5727-01B | DOOR CASH H.S. STS | (101)-1 | 1 |
| *106 | 560-LGBH-08 XFMR | 240-100V XFMR | EMEA | 1 |
| or | 560-1210-08UK | 120-100V XFMR | US | 1 |
| *201 | 020-000620-0B | M6X20 SKT CAP BLK | (414)-4 | 4 |
| *202 | 060-S00600 | M6 WSHR SPR PAS | (414)-4 | 4 |
| *203 | 068-652516 | M6 WSHR 250D FLT PAS | (414)-4 | 4 |
| *301 | | | | |
| *401 | DSD-INST-SD-65 | ASSY INST KIT DSD 65 SDX | | 1 |
| *410 | PK0500 | PALLET DSD SDX | | 1 |
| *411 | PK0501 | SHRINK WRAP DSD SDX | | 1 |
| *412 | | LABEL PACKING | (411)-2 (SIDES) | 2 |
| *413 | | LABEL UNPACKING | (411)-2 (SIDES) | 2 |
| *414 | DSD-0006UK | BRKT SEAT SHIPMENT | | 1 |

② ASSY MAIN CABINET (DSD-9000YUK)

(D-1/5)

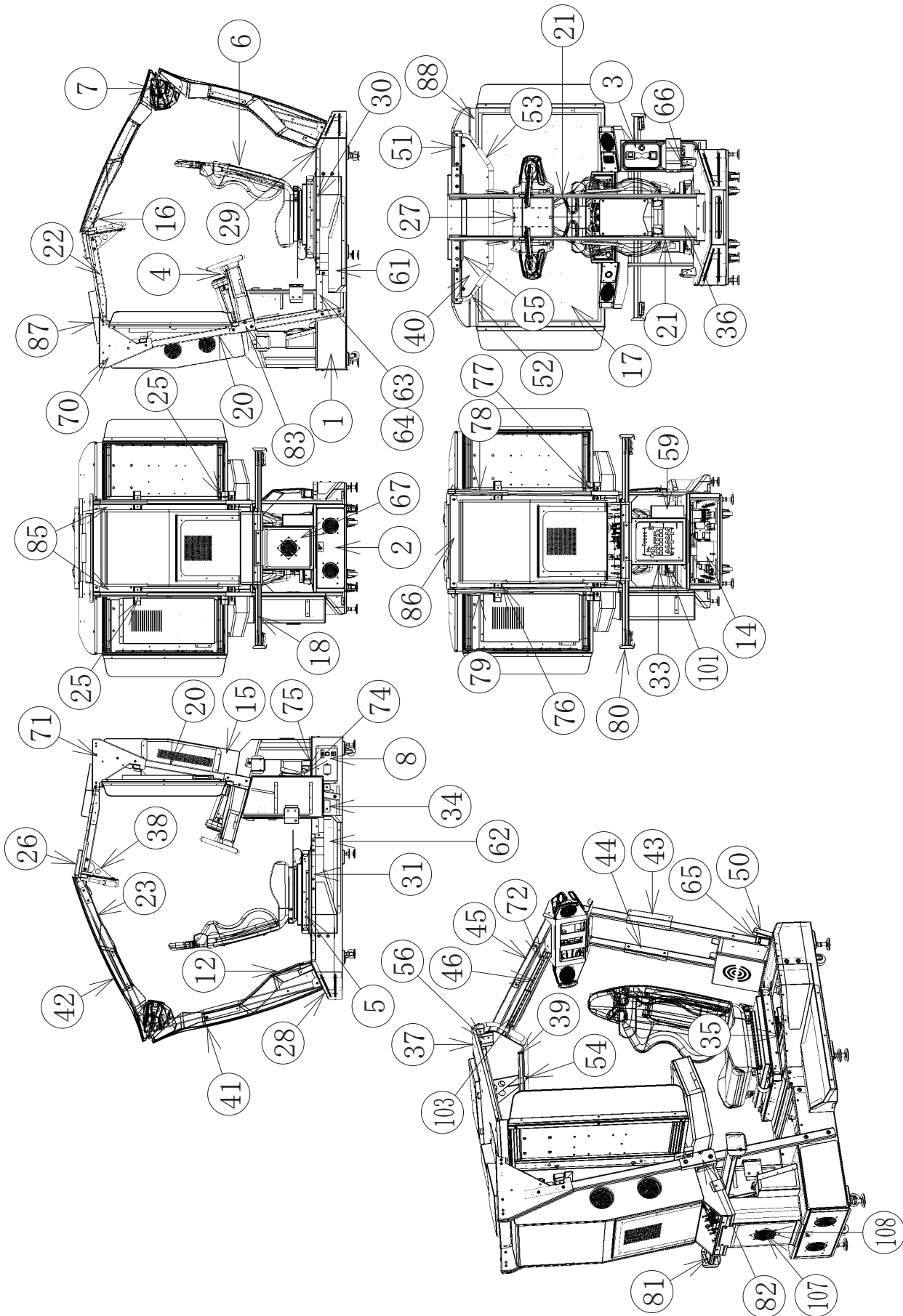

② ASSY MAIN CABINET (DSD-9000YUK)

(D-2/5)

| ITEM NO | PART NO | DESCRIPTION | QTY |
|---------|---------------|-----------------------------|-----------------------------------------------------|
| **1 | DSD-3020XUK | ASSY BASE BOX | 1 |
| **2 | DSD-3050UK | ASSY FRONT LID | LOCK RETAIN 1 |
| **3 | DSD-3100UK | ASSY COIN CHUTE TOWER SDX | 1 |
| **4 | DSD-3200XUK | ASSY CONTROL PANEL SDX | 1 |
| **5 | DSD-2500 | ASSY SLIDE MECHA | 1 |
| **6 | DSD-3400UK | ASSY SEAT | 1 |
| **7 | DSD-3500XUK | ASSY REAR SPEAKER BOX | 1 |
| **8 | DSD-3350UK | AC UNIT SDX | 1 |
| **12 | DSD-3800XUK | ASSY SUB WOOFER | 1 |
| **14 | DSD-4000XUK | ASSY MAIN BD | 1 |
| **15 | DSD-4200UK | ASSY GAMEBOARD | 1 |
| **16 | DSD-3370UK | ASSY HEADER LIGHT | 1 |
| **17 | DSD-9600YUK | ASSY 65 LED SCREEN | 1 |
| **18 | DSD-3620XUK | ASSY SENSOR MTG | 2 |
| **20 | DSD-3001XUK | STRUT FRONT UPRIGHT | 2 |
| **21 | DSD-3002UK | STRUT REAR UPRIGHT | 2 |
| **22 | DSD-9003YUK | STRUT ROOF FRONT | 2 |
| **23 | DSD-3004XUK | STRUT ROOF REAR | 2 |
| **25 | DSD-3006XUK | STRUT BRACE HORIZ | 2 |
| **26 | DSD-3007XUK | BRKT STRUT JOINT ROOF | 1 |
| **27 | DSD-3008XUK | BRKT STRUT JOINT REAR | 1 |
| **28 | DSD-3009XUK | LID REAR | 1 |
| **29 | DSD-3010XUK | LID REAR SMALL | 1 |
| **30 | DSD-3011XUK | COVER SEAT MECHA L | 1 |
| **31 | DSD-3012XUK | COVER SEAT MECHA R | 1 |
| **33 | DSD-3013UK | WIRE COVER BOX | 1 |
| **34 | DSD-3014XUK | BRKT CCT MOUNT | 1 |
| **35 | DSD-3015XUK | BRACE SEAT | 1 |
| **36 | DSD-3016UK | BRACE REAR STRUTS | 1 |
| **37 | DSD-9017YUK | PANEL ROOF HORIZ | 1 |
| **38 | DSD-9701UK | BRKT MAIN HEADER RETAIN | 1 |
| **39 | DSD-9702UK | CHANNEL HEADER RETAIN LOWER | 1 |
| **40 | DSD-9705YUK | HEADER FRONT COVER | 1 |
| ***1 | DSD-9705Y-AUK | HEADER FRONT COVER BLANK | 1 |
| **41 | DSD-3030X-AUK | ASSY COVER MOLD REAR | 1 |
| **42 | DSD-3030X-BUK | ASSY COVER MOLD ROOF | 1 |
| **43 | DSD-3033XUK | BRKT MOULD SIDE REAR L | 1 |
| **44 | DSD-3034XUK | BRKT MOULD SIDE REAR R | 1 |
| **45 | DSD-3035XUK | BRKT MOULD SIDE ROOF L | 1 |
| **46 | DSD-3036XUK | BRKT MOULD SIDE ROOF R | 1 |
| **50 | DSD-3040UK | BRKT MOULD END | 2 |
| **51 | DSD-3041XUK | FRAME HORIZ MIRROR MTG | 1 |
| **52 | DSD-9751YUK | FRAME HEADER | 1 |
| **53 | DSD-3752UK | CUSHION HEADER | (52)-2 2 |
| **54 | DSD-3753UK | SPACER FRAME HEADER | 1 |
| **55 | DSD-3754UK | SASH HEADER RETAIN | 1 |
| **56 | DSD-9755UK | BRKT HEADER RETAIN UPPER | 2 |
| **58 | 280-6696UK | 5.5-20X6.3 WSHR SPCL AL | (40)-4,(43)-2,(44)-2,(45)- 2,(46)-2,(50)-1 14 |
| **59 | TFF-1202UK | FOOTREST BASE | 1 |
| **60 | | | 1 |
| **61 | DSD-3081XUK | STEP TOP L | 1 |
| **62 | DSD-3082XUK | STEP TOP R | 1 |
| **63 | DSD-3085XUK | BASE LID F | 1 |
| **64 | DSD-3086XUK | COVER BASE LID F FRONT | 1 |
| **65 | DSD-9673YUK | BRKT REFLECTOR MTG L | 1 |

② ASSY MAIN CABINET (DSD-9000YUK)

(D-3/5)

ITEM NO PART NO DESCRIPTION QTY

| | | | | |
|-------|-----------------|------------------------------------|----------------------------------------------------------------------|-----|
| **66 | DSD-9674YUK | BRKT REFLECTOR MTG R | | 1 |
| **67 | DSD-3087XUK | LID WIRE COVER | (33)-1 | 1 |
| **70 | DSD-9301YUK | BRKT FRAME CORNER L | | 2 |
| **71 | DSD-9302YUK | BRKT FRAME CORNER R | | 2 |
| **72 | DSD-3303UK | COVER SIDELIGHT INNER | | 2 |
| **73 | SPG-2222UK | ANTI FINGER TRAP PLATE LEFT | | 1 |
| **74 | SPG-2223UK | ANTI FINGER TRAP PLATE RIGHT | | 1 |
| **75 | SPG-2224UK | PEDAL GASKET | (101)-1 | 1 |
| **76 | DSD-9616YUK | BRKT SCREEN UPPER LOCATING | | 1 |
| **77 | DSD-9617YUK | BRKT SCREEN LOWER LOCATING | | 1 |
| **78 | DSD-9618YUK | PANEL SIDE CLOSER LH | | 1 |
| **79 | DSD-9619YUK | PANEL SIDE CLOSER RH | | 1 |
| **80 | DSD-9671YUK | STRUT SENSOR MTG | | 1 |
| **81 | DSD-9672YUK | COVER STRUT SENSOR MTG | | 2 |
| **82 | DSD-3305UK | BRKT FRAME MID L | | 1 |
| **83 | DSD-3306UK | BRKT FRAME MID R | | 1 |
| **85 | DSD-9308UK | BRKT CLOSING PANEL BACK | | 2 |
| **86 | DSD-9901UK | BRKT CLOSING TOP | | 1 |
| **87 | DSD-9902UK | LID TOP LED SCREEN | | 1 |
| **88 | DSD-9903UK | SASH FRONT LED SCREEN | | 1 |
| **89 | DSD-3312UK | STICKER BASE SIDE L | | 1 |
| ***1 | DSD-3312-AUK | STICKER BASE SIDE L BLANK | | 1 |
| **90 | DSD-3313UK | STICKER BASE SIDE R | | 1 |
| ***1 | DSD-3313-AUK | STICKER BASE SIDE R BLANK | | 1 |
| **91 | DSD-3314UK | STICKER MOULD BACK | | 1 |
| ***1 | DSD-3314-AUK | STICKER MOULD BACK BLANK | | 1 |
| **92 | DSD-3315UK | STICKER MOULD ROOF | | 1 |
| ***1 | DSD-3315-AUK | STICKER MOULD ROOF BLANK | | 1 |
| **93 | | | | |
| **94 | DSD-3317UK | STICKER CCT | | 1 |
| ***1 | DSD-3317-AUK | STICKER CCT BLANK | | 1 |
| **95 | | | | 1 |
| **96 | DSD-3395UK | BRKT CAMERA MTG MKII | MOUNTED TO BACK DSD-4200UK | 1 |
| **97 | DSD-3392UK | COVER MTG CAMERA | MOUNTED TO DSD-3307UK | 1 |
| **101 | SPG-2200-01 | ASSY ACCEL&BRAKE | | 1 |
| **102 | | | | 1 |
| **103 | 390-2012-080RGB | LED FLX STRIP RGB 12V 80CM | STRUT ROOF | 2 |
| **104 | OS1230 | FOAM STRIP 2MM X 10MM | (55)-0.6M | 0.6 |
| **105 | XXX | CAMERA | | 1 |
| **106 | 280-K02529-WX | DRIVE FASTENER 25FH 24L 7.9DIA | (5)-2 | 2 |
| **107 | 260-0012-01UK | FAN DC 12V RoHS EEC0381B1-000U-A99 | | 1 |
| **108 | FN1012 | FAN GUARD METAL 120MM (FG-12) | | 1 |
| **109 | 130-04030-E | SPKR ELIP 4OHM 30W VIS DX4x6P | | 1 |
| **201 | 020-000830-0B | M8X30 SKT CAP BLK | (3)-3,(4)-2,(14)-1,(15)-4,(26)-4,(27)-8,(37)-4,(38)-1,(80)-2,(101)-4 | 33 |

② ASSY MAIN CABINET (DSD-9000YUK)

(D-4/5)

| ITEM NO | PART NO | DESCRIPTION | QTY | |
|---------|---------------|-------------------------|----------------------------------------------------------------------------------------------------------------------------------------------------------------------------------------------------------|-----|
| **202 | 060-S00800-0B | M8 WSHR SPR BLK | (3)-3,(4)-4,(5)-8,(7)-6,(15)-4,(17)-2,(20)-2,(21)-2,(22)-5,(23)-4,(25)-4,(26)-10,(27)-8,(36)-4,(37)-4,(38)-1,(51)-4,(59)-4,(70)-2,(71)-2,(80)-2,(82)-3,(83)-3,(86)-4,(101)-4 | 117 |
| **203 | 068-852216-0B | M8 WSHR 22OD FLT BLK | (3)-5,(4)-4,(5)-8,(7)-6,(14)-1,(15)-4,(17)-2,(20)-2,(21)-2,(22)-5,(23)-4,(25)-4,(26)-10,(27)-8,(34)-2,(36)-4,(37)-4,(38)-1,(51)-4,(59)-4,(70)-2,(71)-2,(76)-4,(77)-4,(80)-2,(82)-3,(83)-3,(86)-4,(101)-4 | 132 |
| **204 | 050-U00800 | M8 NUT NYLOK PAS | (3)-2,(76)-2,(77)-2,(80)-2 | 10 |
| **205 | 029-B00820-0B | M8X20 SKT BH BLK | (4)-2,(59)-4 | 6 |
| **206 | 030-000840 | M8X40 BLT PAS | (5)-8 | 8 |
| **207 | 020-001030-0B | M10X30 SKT CAP BLK | (6)-4 | 4 |
| **208 | 060-S01000-0B | M10 WSHR SPR BLK | (6)-4 | 4 |
| **209 | 060-F01000-0B | M10 WSHR FORM A FLT BLK | (6)-4 | 4 |
| **210 | 020-000820-0B | M8X20 SKT CAP BLK | (7)-6,(21)-2,(22)-5,(23)-4,(26)-6,(51)-4,(70)-2,(71)-2,(86)-4 | 37 |
| **211 | 029-B00412-0B | M4X12 SKT BH BLK | (8)-4,(16)-4,(28)-6,(29)-4,(35)-4,(65)-2,(66)-2,(72)-8,(78)-3,(79)-3,(81)-2,(86)-4,(87)-5,(96)-4 | 69 |
| **212 | 060-S00400-0B | M4 WSHR SPR BLK | (8)-4,(12)-4,(16)-4,(17)-2,(28)-6,(29)-4,(35)-4,(39)-4,(41)-2,(42)-2,(65)-2,(66)-2,(67)-2,(72)-8,(78)-3,(79)-3,(81)-2,(86)-4,(87)-5,(96)-4,(108)-4 | 89 |
| **213 | 068-441616-0B | M4 WSHR 16OD FLT BLK | (8)-4,(12)-4,(17)-2,(28)-6,(29)-4,(35)-4,(41)-2,(42)-2,(63)-6,(67)-2,(72)-8,(78)-3,(79)-3,(81)-2,(86)-4,(87)-5,(96)-4,(97)-2 | 81 |
| **214 | 050-F00400 | M4 NUT FLG SER PAS | (8)-1,(18)-1,(63)-6,(97)-2 | 11 |
| **215 | 020-000880-0B | M8X80 SKT CAP BLK | (76)-2,(77)-2,(82)-1,(83)-1 | 6 |
| **216 | 050-C00800-3C | M8 NUT DOME TYPE 3 CRM | (76)-2,(77)-2 | 4 |
| **217 | 029-B00840-0B | M8X40 SKT BH BLK | (25)-4,(82)-2,(83)-2 | 12 |
| **218 | 020-F00830-0B | M8X30 SKT CSK BLK | (52)-2 | 2 |
| **219 | 020-000850-0B | M8X50 SKT CAP BLK | (20)-2,(36)-4 | 8 |
| **220 | 029-B00430-0B | M4X30 SKT BH BLK | (12)-4 | 4 |
| **221 | 029-B00620-0B | M6X20 SKT BH BLK | (33)-4,(41)-2,(42)-2,(43)-2,(44)-2,(45)-2,(46)-2,(50)-2,(55)-2,(56)-2,(84)-4 | 30 |

② ASSY MAIN CABINET (DSD-9000YUK)

(D-5/5)

| ITEM NO | PART NO | DESCRIPTION | QTY | |
|---------|-----------------|--------------------------|--------------------------------------------------------------------------------------------------------------------------------------|----|
| **222 | 060-S00600-0B | M6 WSHR SPR BLK | (33)-4,(38)-2,(41)-2,(42)-2,(43)-2,(44)-2,(45)-2,(46)-2,(50)-2,(55)-2,(56)-2,(65)-2,(66)-2,(78)-3,(79)-3,(85)-2,(86)-2,(88)-4 | 48 |
| **223 | 068-652016-0B | M6 WSHR 20OD FLT BLK | (17)-2,(33)-4,(38)-2,(41)-2,(42)-2,(43)-2,(44)-2,(45)-2,(46)-2,(50)-2,(55)-2,(56)-2,(65)-2,(66)-2,(78)-3,(79)-3,(85)-2,(86)-2,(88)-4 | 50 |
| **224 | 060-F00400-0B | M4 WSHR FORM A FLT BLK | (16)-4,(65)-2,(66)-2 | 8 |
| **225 | 008-0S0412 | M4X12 TMP PRF STN | (30)-5,(31)-5,(61)-4,(62)-4 | 18 |
| **226 | 060-S00400 | M4 WSHR SPR PAS | (30)-5,(31)-5,(61)-4,(62)-4 | 18 |
| **227 | 068-441616-0C | M4 WSHR 16OD FLT CRM | (30)-5,(31)-5,(61)-4,(62)-4 | 18 |
| **228 | 029-B00416-0B | M4X16 SKT BH BLK | (17)-2,(41)-2,(42)-2,(67)-2,(108)-4 | 12 |
| **229 | 020-0S0510 | M5X10 SKT CAP STNLS | (40)-4,(41)-6,(42)-4 | 14 |
| **230 | 020-F00660-0B | M6X60 SKT CSK BLK | (52)-1 | 1 |
| **231 | 029-B00512-0B | M5X12 SKT BH BLK | (39)-2,(76)-1 | 3 |
| **232 | 029-B00620 | M6X20 SKT BH PAS | (64)-3 | 3 |
| **233 | 060-S00600 | M6 WSHR SPR PAS | (64)-3 | 3 |
| **234 | 068-652016 | M6 WSHR 20OD PAS | (64)-3 | 3 |
| **235 | 060-S00500-0B | M5 WSHR SPR BLK | (39)-2,(76)-1 | 3 |
| **236 | 068-551616-0B | M5 WSHR 16OD FLT BLK | (39)-2,(76)-1 | 3 |
| **237 | 060-F00800-0B | M8 WSHR FORM A FLT BLK | (52)-1 | 1 |
| **238 | | | (96)-4 | 4 |
| **239 | 050-U00400 | M4 NUT NYLOK PAS | (107)-4 | 4 |
| **240 | 030-000816 | M8X16 BLT PAS | (17)-2 | 2 |
| **241 | 050-U00600 | M6 NUT NYLOK PAS | (17)-2,(18)-1 | 4 |
| **242 | 068-651616 | M6 WSHR 16OD FLT PAS | (18)-1 | 2 |
| **243 | 020-000616-0B | M6X16 SKT CAP BLK | (38)-2,(65)-2,(66)-2,(78)-3,(79)-3,(85)-2,(86)-2,(88)-4 | 22 |
| **244 | 020-000640-0B | M6X40 SKT CAP BLK | (85)-2 | 4 |
| **245 | 012-P00410-F | N8X3/8" S/TAP FLG PAS | (77)-4,(109)-4 | 8 |
| **301 | | | | 1 |
| **302 | DSD-60020UK | WH REAR STRUTS | | 2 |
| **303 | DSD-60023UK | WH WOOFER EXTN | | 1 |
| **304 | 600-7141-100UK | CABLE JVS TYPE A-B 100cm | | 1 |
| **305 | 600-7009-2500UK | ASSY RGB CA D-SUB 15 | | 1 |
| **306 | 600-9010-44K | WH EARTH 10CM M4/M4 K | | 1 |
| **307 | 600-9020-44K | WH EARTH 20CM M4/M4 K | | 1 |
| **308 | 600-9030-44K | WH EARTH 30CM M4/M4 K | | 1 |
| **309 | 600-9050-44K | WH EARTH 50CM M4/M4 K | | 1 |
| **310 | 600-9060-44K | WH EARTH 60CM M4/M4 K | | 1 |
| **311 | 600-9120-44K | WH EARTH 120CM M4/M4 K | | 1 |

③ ASSY 65 LCD SCREEN (DSD-9600YUK

(D-1/2)

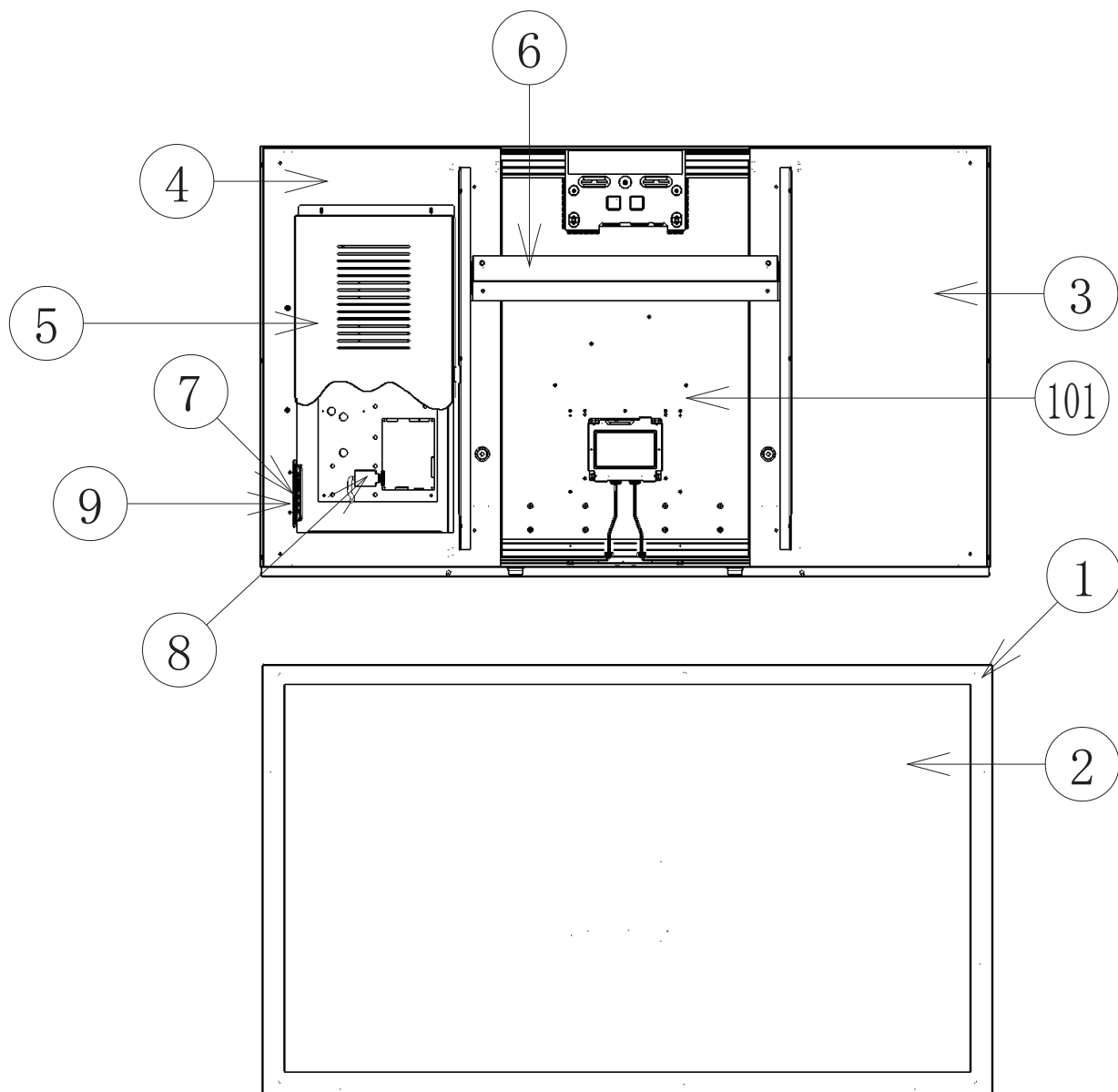

③ ASSY 65 LCD SCREEN (DSD-9600YUK

(D-2/2)

| ITEM NO | PART NO | DESCRIPTION | QTY |
|---------|-----------------|---------------------------------|-------------------------------------|
| ***1 | DSD-9601YUK | SHROUD 65 SCREEN | 1 |
| ***2 | DSD-9602YUK | GLASS SCREEN PROTECT | 1 |
| ***3 | DSD-9603YUK | COVER REAR LH | 1 |
| ***4 | DSD-9604YUK | COVER REAR RH | 1 |
| ***5 | DSD-9605YUK | COVER ELEC ACCESS | 1 |
| ***6 | DSD-9606YUK | BRKT LED UPPER MOUNT | 1 |
| ***7 | DSD-9607YUK | BRKT DM OSD MOUNT | 1 |
| ***8 | DSD-9610YUK | ASSY SCREEN ELEC | 1 |
| ***9 | DSD-5111UK | PLATE OSD COVER | 1 |
| ***101 | 200-6065-02-AUO | DISPLAY 65" LED AUO P650HVN02.4 | 1 |
| ***102 | 440-DS0010UK | STICKER DANGER HIGH VOLTAGE | 1 |
| ***103 | OS1230 | FOAM STRIP 2MM X 10MM | 2.3 |
| ***201 | 000-P00308 | M3X8 MSCR PAN PAS | (OSD)-2 2 |
| ***202 | 000-P00316 | M3X16 MSCR PAN PAS | (8)-4 4 |
| ***203 | 012-P00320 | N4X3/4" S/TAP PAN PAS | (102)-4,(PRISMA)-4 8 |
| ***204 | 029-B00412-0B | M4X12 SKT BH BLK | (3)-4,(4)-4,(5)-2,(7)-2,(9)-2 14 |
| ***205 | 030-000816 | M8X16 BLT PAS | (6)-2 2 |
| ***206 | 050-F00400 | M4 NUT FLG SER PAS | (1)-4 4 |
| ***207 | 060-S00400 | M4 WSHR SPR PAS | (1)-4 4 |
| ***208 | 060-S00400-0B | M4 WSHR SPR BLK | (3)-4,(4)-4,(5)-2,(7)-2,(9)-2 14 |
| ***209 | 060-S00800-0B | M8 WSHR SPR BLK | (6)-2 2 |
| ***210 | 068-330808-PN | M3 WSHR 8OD FLT NYLON | (OSD)-2 2 |
| ***211 | 068-441616 | M4 WSHR 16OD FLT PAS | (1)-4,(8)-4 8 |
| ***212 | 068-441616-0B | M4 WSHR 16OD FLT BLK | (3)-4,(4)-4,(5)-2,(7)-2,(9)-2 14 |
| ***213 | 068-852216-0B | M8 WSHR 22OD FLT BLK | (6)-2 2 |

④ ASSY SCREEN ELEC (DSD-9610YUK)

(D-1/1)

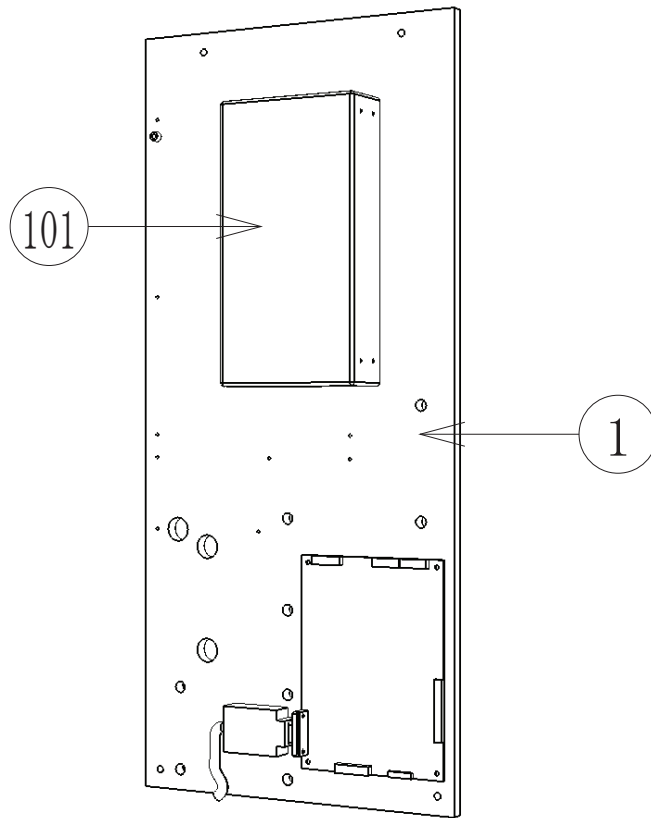

| ITEM NO | PART NO | DESCRIPTION | QTY |
|---------|---------------|-------------------------------|-------------------------------|
| ****1 | DSD-9611YUK | BOARD SCREEN ELEC MOUNT | 1 |
| ****2 | TRF-1212UK | BRKT LED FILTER | 1 |
| ****101 | 400-0450-0024 | PSU 24VDC 450W AK-450-24 | 1 |
| ****102 | EP1419 | FILTER SCHAFFNER 2030-16-06 | 1 |
| ****103 | 280-A01264-WX | ROUTER TWIST D12 SO6.4 WOOD X | 8 |
| ****104 | 280-L00605-OS | STANDOFF 6.35OD 3.56ID 4.76L | (PRISMA)-4 4 |
| ****201 | 000-F00316 | M3X16 MSCR CSK PAS | (101)-4 4 |
| ****202 | 000-P00410-W | M4X10 MSCR PAN W/FS PAS | (102)-2,(filter earth)-1 3 |
| ****203 | 012-P00312 | N4X1/2" S/TAP PAN PAS | (2)-2,(PRISMA)-4 6 |

⑤ ASSY SCREEN SIDE LIGHT L (DSD-9620YUK)

(D-1/1)

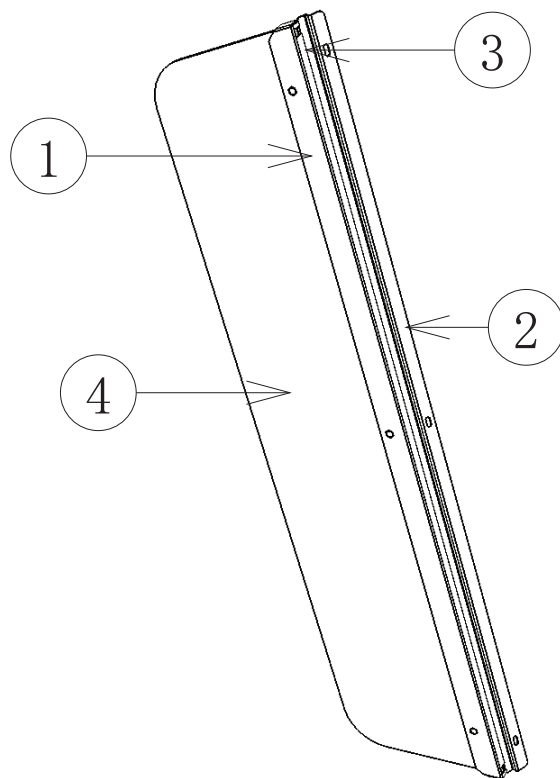

| ITEM NO | PART NO | DESCRIPTION | | QTY |
|---------|-----------------|------------------------------|-------------------|-----|
| ***1 | DSD-9621YUK | BRKT SCREEN SIDE LIGHT FRONT | | 1 |
| ***2 | DSD-9622YUK | BRKT SCREEN SIDE LIGHT REAR | | 1 |
| ***3 | DSD-9623YUK | SPACER SCREEN SIDE LIGHT | BETWEEN (1) & (2) | 1 |
| ***4 | DSD-9624YUK | PLATE SCREEN SIDE L | BETWEEN (1) & (2) | 1 |
| ***101 | 390-2012-100RGB | LED FLX STRIP RGB 12V 100CM | | 1 |
| ***102 | BE-6001UK | ASSY LED CLIP | | 1 |
| ***201 | 029-B00412-0B | M4X12 SKT BH BLK | (2)-3 | 3 |
| ***202 | 060-S00400-0B | M4 WSHR SPR BLK | (2)-3 | 3 |
| ***203 | 068-441616-0B | M4 WSHR 16OD FLT BLK | (2)-3 | 3 |

⑥ ASSY SCREEN SIDE LIGHT R (DSD9625YUK(

(D-1/1)

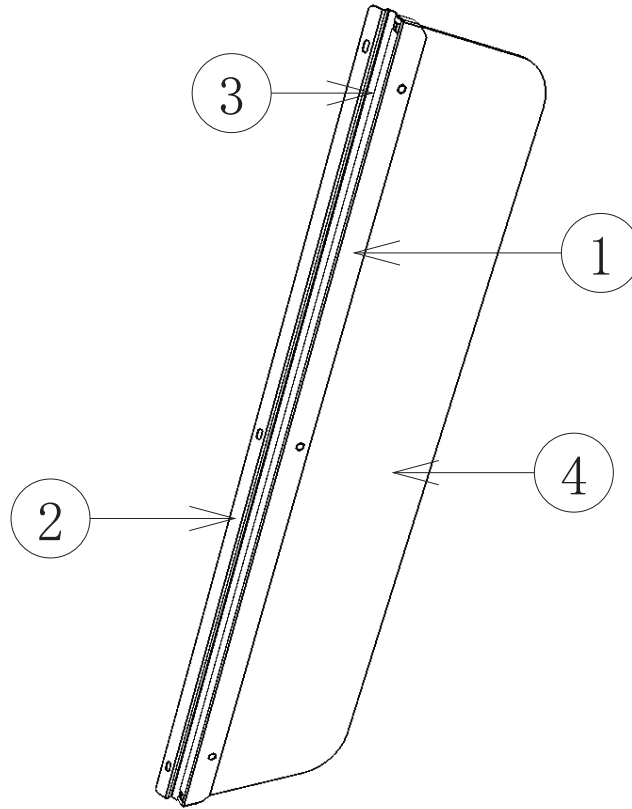

| ITEM NO | PART NO | DESCRIPTION | | QTY |
|---------|-----------------|------------------------------|-------------------|-----|
| ***1 | DSD-9621YUK | BRKT SCREEN SIDE LIGHT FRONT | | 1 |
| ***2 | DSD-9622YUK | BRKT SCREEN SIDE LIGHT REAR | | 1 |
| ***3 | DSD-9623YUK | SPACER SCREEN SIDE LIGHT | BETWEEN (1) & (2) | 1 |
| ***4 | DSD-9626YUK | PLATE SCREEN SIDE R BLANK | BETWEEN (1) & (2) | 1 |
| ***101 | 390-2012-100RGB | LED FLX STRIP RGB 12V 100CM | | 1 |
| ***102 | BE-6001UK | ASSY LED CLIP | | 1 |
| ***201 | 029-B00412-0B | M4X12 SKT BH BLK | (2)-3 | 3 |
| ***202 | 060-S00400-0B | M4 WSHR SPR BLK | (2)-3 | 3 |
| ***203 | 068-441616-0B | M4 WSHR 16OD FLT BLK | (2)-3 | 3 |

⑦ ASSY BASE BOX (DSD-3020XUK)

(D-1/2)

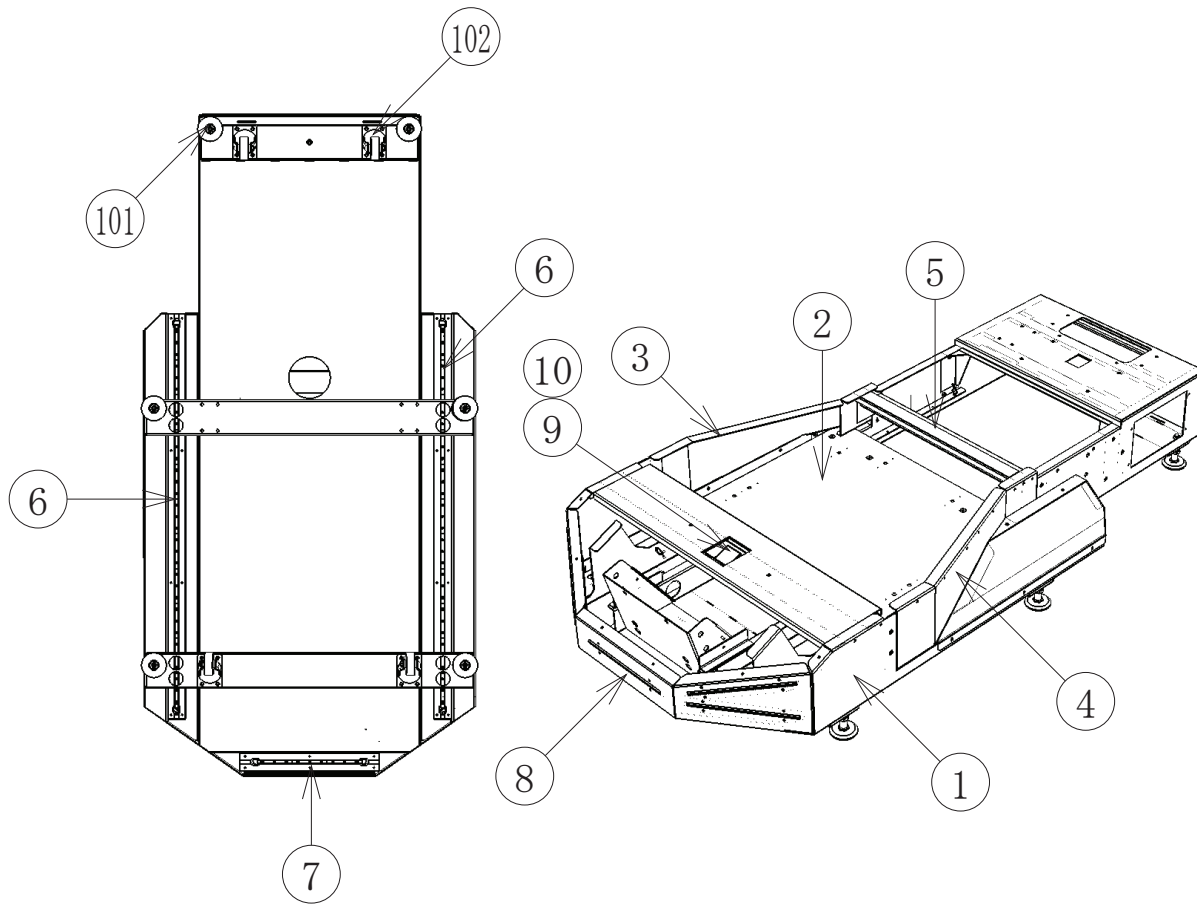

7 ASSY BASE BOX (DSD-3020XUK)

(D-2/2)

| ITEM NO | PART NO | DESCRIPTION | | QTY |
|---------|---------------|------------------------------|-------------------|-----|
| ***1 | DSD-3021XUK | MAIN BASE BLANK | | 1 |
| ***2 | DSD-3022XUK | SEAT BASE BOARD | | 1 |
| ***3 | DSD-3023XUK | PANEL MAIN BASE L | | 1 |
| ***4 | DSD-3024XUK | PANEL MAIN BASE R | | 1 |
| ***5 | DSD-3025XUK | BRACE SEAT FRONT | | 1 |
| ***6 | DSD-3060UK | ASSY BASE DOWNLIGHT SIDE | | 2 |
| ***7 | DSD-3070UK | ASSY BASE DOWNLIGHT REAR | | 1 |
| ***8 | DSD-3090UK | ASSY BASE BACKLIGHT REAR | | 5 |
| ***9 | DSD-3026XUK | BRKT REFLECTOR MTG | | 1 |
| ***10 | DSD-3027XUK | WINDOW STOP SENSOR REAR 01 | DROP-IN | 1 |
| ***101 | 601-0004UK-01 | LEG ADJ M16X100X70DIA 1L/NUT | SCREW-IN | 6 |
| ***102 | MA1007 | CASTOR SWIVEL 63mm NYLON | | 4 |
| ***201 | 020-F00830-0B | M8X30 SKT CSK BLK | (2)-8 | 8 |
| ***202 | 029-B00820-0B | M8X20 SKT BH BLK | (3)-3,(4)-3 | 6 |
| ***203 | 060-S00800-0B | M8 WSHR SPR BLK | (3)-3,(4)-3 | 6 |
| ***204 | 068-852216-0B | M8 WSHR 22OD FLT BLK | (3)-3,(4)-3 | 6 |
| ***205 | 029-B00412-0B | M4X12 SKT BH BLK | (5)-4 | 4 |
| ***206 | 060-S00400-0B | M4 WSHR SPR BLK | (5)-4,(6)-4,(7)-3 | 15 |
| ***207 | 068-441616-0B | M4 WSHR 16OD FLT BLK | (5)-4,(6)-4,(7)-3 | 15 |
| ***208 | 000-P00412 | M4X12 MSCR PAN PAS | (6)-4,(7)-3 | 11 |
| ***209 | 050-F00400 | M4 NUT FLG SER PAS | (8)-4,(9)-2 | 22 |
| ***210 | 050-U00400 | M4 NUT NYLOK PAS | (REFLECTOR)-2 | 2 |
| ***211 | 030-000816 | M8X16 BLT PAS | (102)-4 | 16 |
| ***212 | 060-S00800 | M8 WSHR SPR PAS | (102)-4 | 16 |
| ***213 | 060-F00800 | M8 WSHR FORM A FLT PAS | (102)-4 | 16 |
| ***306 | DSD-60018UK | WH CTRL PANEL TO BASE | | 1 |
| ***307 | DSD-60019UK | WH BASE TO REAR | | 1 |
| ***309 | DSD-60028UK | WH SERIAL RGB DOUBLE | | 1 |
| ***310 | DSD-60038UK | WH SERIAL LED STRUT | | 2 |
| ***311 | DSD-60039UK | WH LED CLIP DOUBLE | | 2 |
| ***312 | BE-6001UK | ASSY LED CLIP | | 6 |
| ****101 | EP1427 | 4 WAY JST SMP-04V-BC | | 1 |
| ****102 | EP1428 | TERM-JST SHF-001T-0.BS | | 4 |
| ****301 | RND-60059 | WH LED CLIP SUZO QL0129 | | 1 |

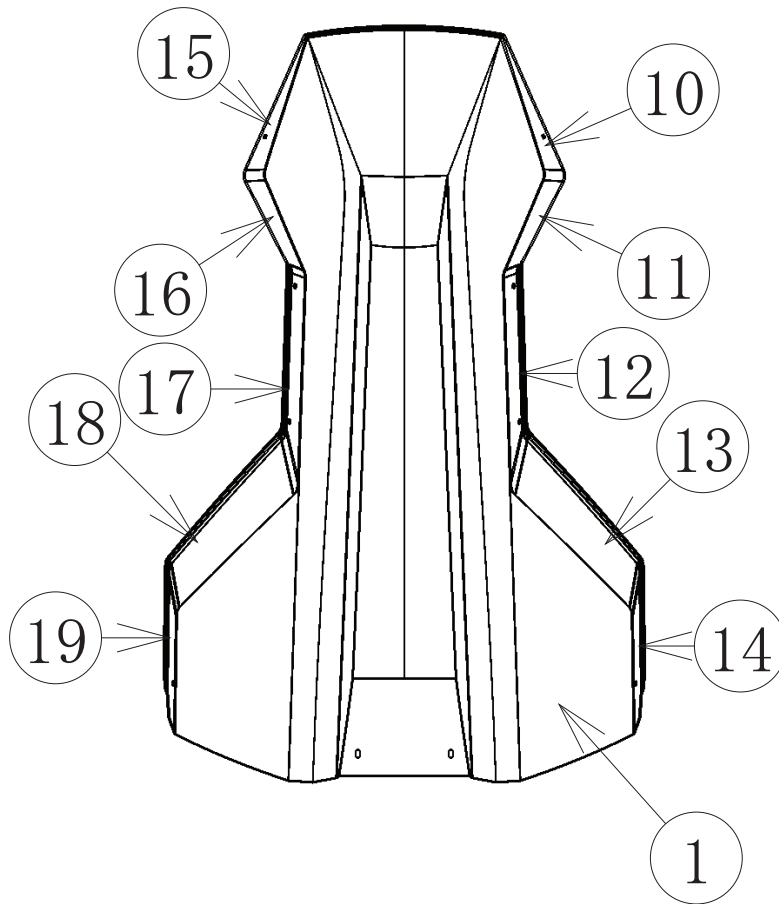

| ITEM NO | PART NO | DESCRIPTION | | QTY |
|---------|----------------|------------------------|-------|-----|
| ***1 | DSD-3031XUK | COVER MOULD REAR | | 1 |
| ***10 | DSD-3031X-LBUK | STICKER MOULD REAR L B | (1)-1 | 1 |
| ***11 | DSD-3031X-LCUK | STICKER MOULD REAR L C | (1)-1 | 1 |
| ***12 | DSD-3031X-LDUK | STICKER MOULD REAR L D | (1)-1 | 1 |
| ***13 | DSD-3031X-LEUK | STICKER MOULD REAR L E | (1)-1 | 1 |
| ***14 | DSD-3031X-LFUK | STICKER MOULD REAR L F | (1)-1 | 1 |
| ***15 | DSD-3031X-RBUK | STICKER MOULD REAR R B | (1)-1 | 1 |
| ***16 | DSD-3031X-RCUK | STICKER MOULD REAR R C | (1)-1 | 1 |
| ***17 | DSD-3031X-RDUK | STICKER MOULD REAR R D | (1)-1 | 1 |
| ***18 | DSD-3031X-REUK | STICKER MOULD REAR R E | (1)-1 | 1 |
| ***19 | DSD-3031X-RFUK | STICKER MOULD REAR R F | (1)-1 | 1 |

⑨ ASSY COVER MOULD ROOF (DSD-3030-BUK)

(D-1/1)

18

PARTS LIST

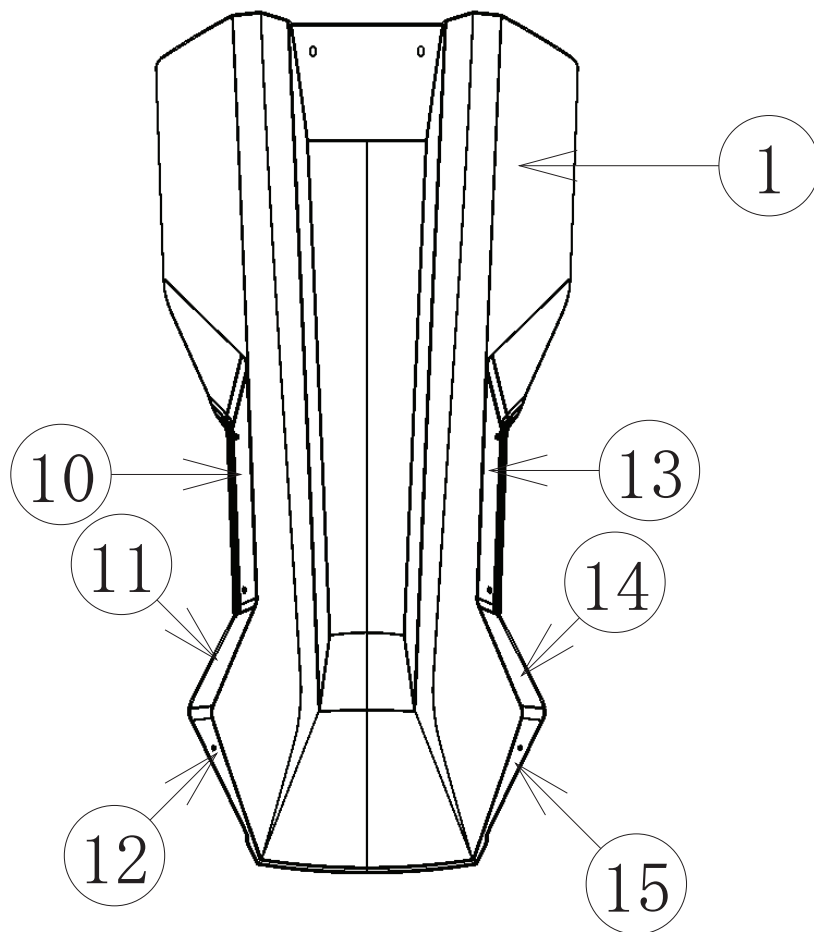

| ITEM NO | PART NO | DESCRIPTION | | QTY |
|---------|----------------|------------------------|-------|-----|
| ***1 | DSD-3032XUK | COVER MOULD ROOF | | 1 |
| ***10 | DSD-3032X-LDUK | STICKER MOULD ROOF L D | (1)-1 | 1 |
| ***11 | DSD-3032X-LEUK | STICKER MOULD ROOF L E | (1)-1 | 1 |
| ***12 | DSD-3032X-LFUK | STICKER MOULD ROOF L F | (1)-1 | 1 |
| ***13 | DSD-3032X-RDUK | STICKER MOULD ROOF R D | (1)-1 | 1 |
| ***14 | DSD-3032X-REUK | STICKER MOULD ROOF R E | (1)-1 | 1 |
| ***15 | DSD-3032X-RFUK | STICKER MOULD ROOF R F | (1)-1 | 1 |

⑩ ASSY FRONT LID (DSD-3050UK)

(D-1/1)

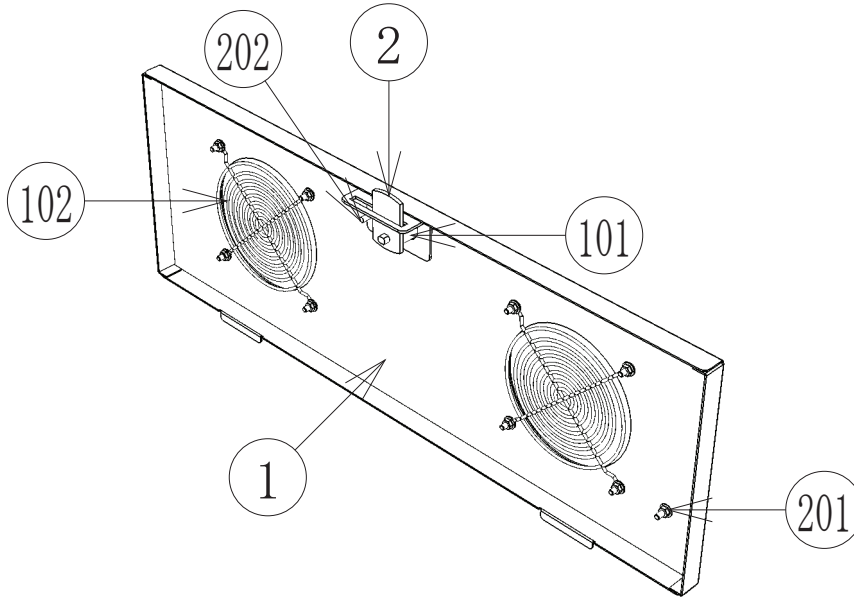

| ITEM NO | PART NO | DESCRIPTION | QTY |
|---------|---------------|-------------------------------------|-----------------|
| ***1 | DSD-3051UK | FRONT LID | 1 |
| ***2 | DP-1167UK | TNG LKG | (101)-1 |
| ***101 | 220-5575UK | LOCK (J9117) KEY TO LIKE 22MM W CAM | 1 |
| ***102 | FN1012 | FAN GUARD METAL 120MM (FG-12) | 2 |
| ***201 | 050-F00400 | M4 NUT FLG SER PAS | (102)-4,EARTH-1 |
| ***202 | 029-B00430-0B | M4X30 SKT BH BLK | LOCK RETAINER |

⑪ ASSY BASE DOWNLIGHT SIDE (DSD-3060UK)

(D-1/1)

18

PARTS LIST

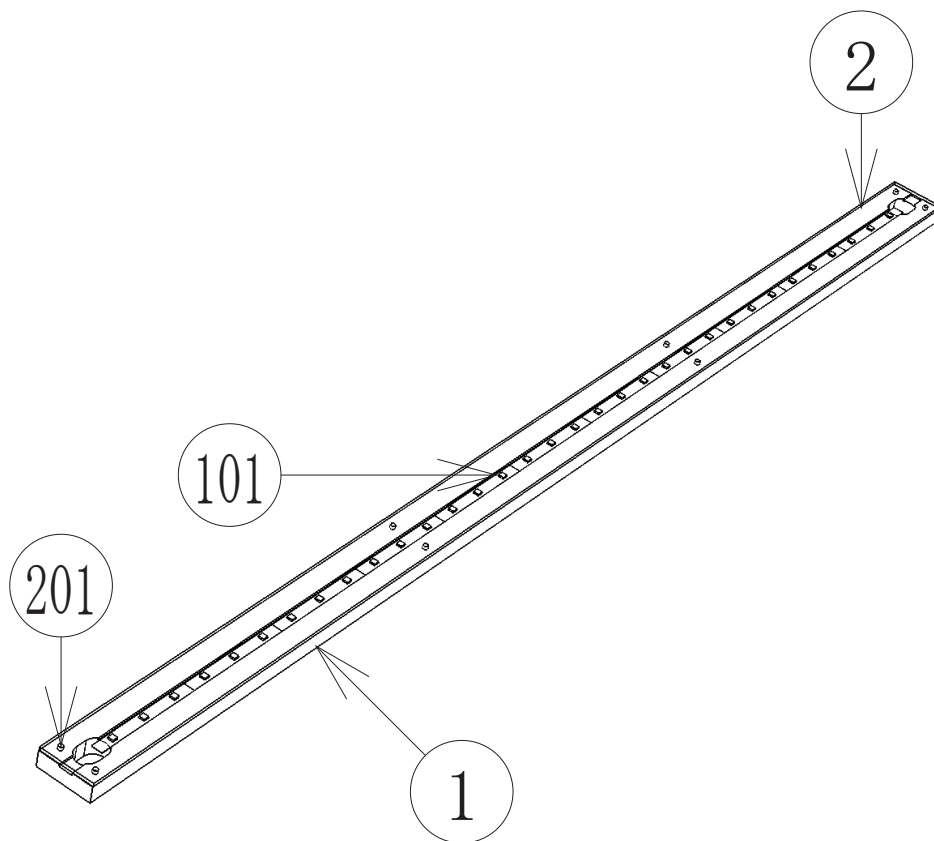

| ITEM NO | PART NO | DESCRIPTION | QTY |
|---------|-----------------|-----------------------------|-------|
| ****1 | DSD-3061UK | BASE DOWNLIGHT SIDE | 1 |
| ****2 | DSD-3062UK | COVER DOWNLIGHT SIDE | 1 |
| ****101 | 390-2012-110RGB | LED FLX STRIP RGB 12V 110CM | 1 |
| ****201 | 012-P03516-FZ | N6X5/8" S/TAP PAN FLG 0Z | (2)-2 |

⑫ ASSY BASE DOWNLIGHT REAR (DSD-3070UK)

(D-1/1)

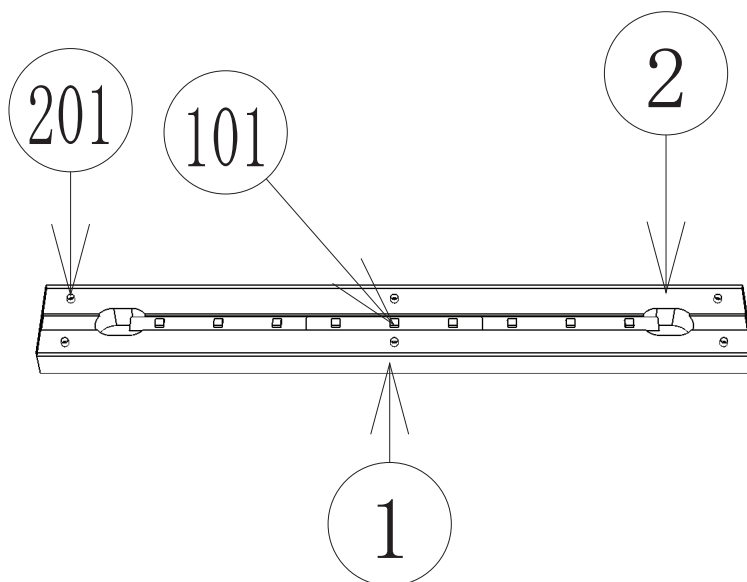

| ITEM NO | PART NO | DESCRIPTION | QTY |
|---------|-----------------|----------------------------|---------|
| ****1 | DSD-3071UK | BASE DOWNLIGHT REAR | 1 |
| ****2 | DSD-3072UK | COVER DOWNLIGHT REAR | 1 |
| ****101 | 390-2012-030RGB | LED FLX STRIP RGB 12V 30CM | 1 |
| ****201 | 012-P03516-FZ | N6X5/8" S/TAP PAN FLG 0Z | (2)-2 6 |

⑬ ASSY BASE BACKLIGHT REAR (DSD-3090UK)

(D-1/1)

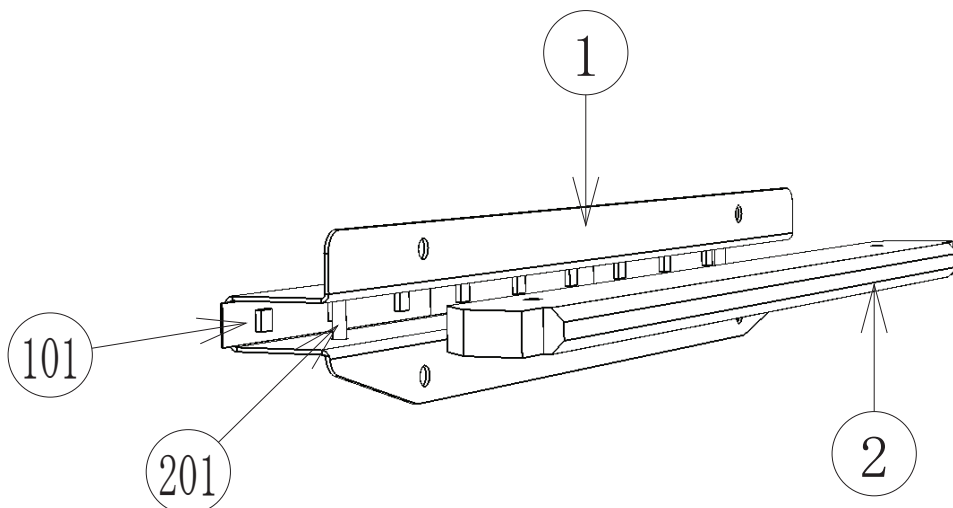

| ITEM NO | PART NO | DESCRIPTION | QTY |
|---------|-----------------|----------------------------|-------|
| ****1 | DSD-3091UK | BASE BACKLIGHT REAR | 1 |
| ****2 | DSD-3092UK | PLATE LED LIGHT REAR | 1 |
| ****101 | 390-2012-030RGB | LED FLX STRIP RGB 12V 30CM | 1 |
| ****201 | 020-000316-0Z | M3X16 SKT CAP 0Z | (2)-2 |

14 ASSY COIN CHUTE TOWER SDX (DSD-3100UK)

(D-1/1)

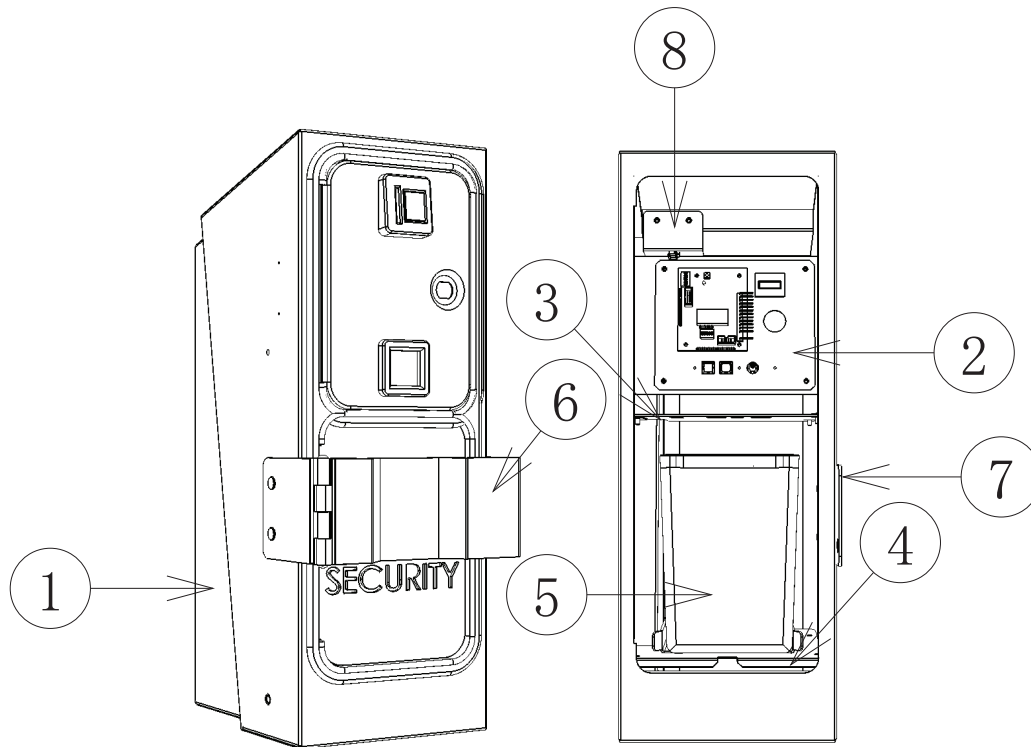

| ITEM NO | PART NO | DESCRIPTION | QTY |
|---------|-------------|-----------------------------|----------------|
| ***1 | DSD-3101UK | COIN CHUTE TOWER SDX | 1 |
| ***2 | DSD-3150UK | ASSY SWITCH UNIT | 1 |
| ***3 | DSD-3102UK | COIN PATH PLATE | 1 |
| ***4 | DSD-3103UK | CCT FLOOR | 1 |
| ***5 | PP1087 | BOX CASH FOR MINI DOOR | 1 |
| ***6 | TFF-0304UK | LOCKING HASP | 1 |
| ***7 | TFF-0305UK | BRKT PADLOCK | 1 |
| ***8 | DSD-3104UK | BRKT COVER DBA HARNESS | 1 |
| ***101 | OS1247 | ALUMINIUM STICKY CLIP ASK-3 | 3 |
| ***201 | 000-P00412 | M4X12 MSCR PAN PAS | (2)-4,(4)-3 |
| ***202 | 060-S00400 | M4 WSHR SPR PAS | (2)-4,(4)-3 |
| ***203 | 060-F00400 | M4 WSHR FORM A FLT PAS | (2)-4,(4)-3 |
| ***204 | 050-F00400 | M4 NUT FLG SER PAS | (3)-3, 1-EARTH |
| ***205 | 050-U00800 | M8 NUT NYLOK PAS | (6)-2,(7)-2 |
| ***206 | 068-852216 | M8 WSHR 22OD FLT PAS | (6)-2,(7)-2 |
| ***301 | DSD-60012UK | WH COIN HANDLING | 1 |
| ***302 | DSD-60049UK | WH DBA POWER | 1 |

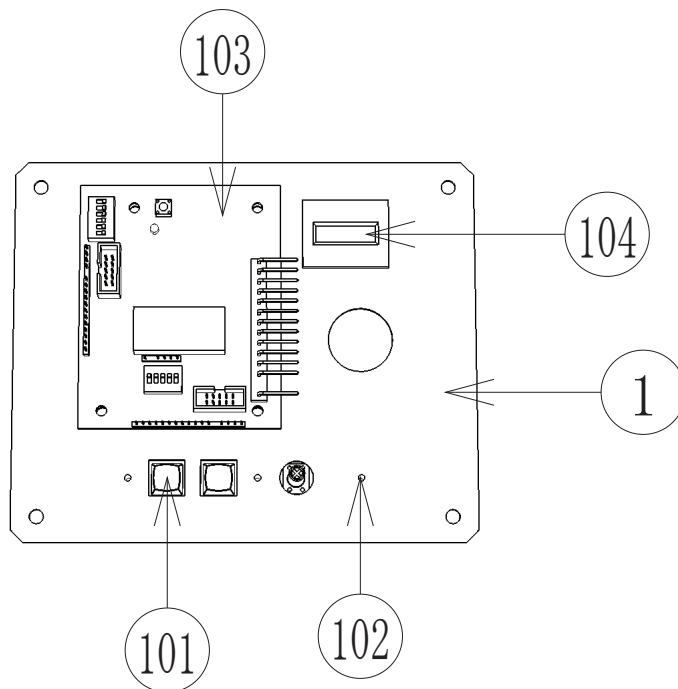

| ITEM NO | PART NO | DESCRIPTION | | QTY |
|---------|----------------|-----------------------------|---------|-----|
| ****1 | RD-0321-01UK | SW BRKT US | | 1 |
| ****101 | 838-14548-01UK | SW & VOL CTL BD | | 1 |
| ****102 | 280-L00706-PM | STANDOFF 6.4MM HOLE PM | (103)-4 | 4 |
| ****103 | EP1380-01 | CREDIT BOARD EXCEL | | 1 |
| ****104 | 220-5643UK | COIN METER SMALL 12V | | 1 |
| ****105 | OS1247 | ALUMINIUM STICKY CLIP ASK-3 | | 1 |
| ****106 | OS1098 | CRIMP BELL END SMALL | | 2 |
| ****107 | 601-0460 | CABLE TIE NYLON 100MM | | 2 |
| ****201 | 000-P00308 | M3X8 MSCR PAN PAS | (101)-3 | 3 |
| ****202 | 060-F00300 | M3 WSHR FORM A FLT PAS | (101)-3 | 3 |
| ****203 | 060-S00300 | M3 WSHR SPR PAS | (101)-3 | 3 |
| ****301 | DSD-60012UK | WH COIN HANDLING | | 1 |

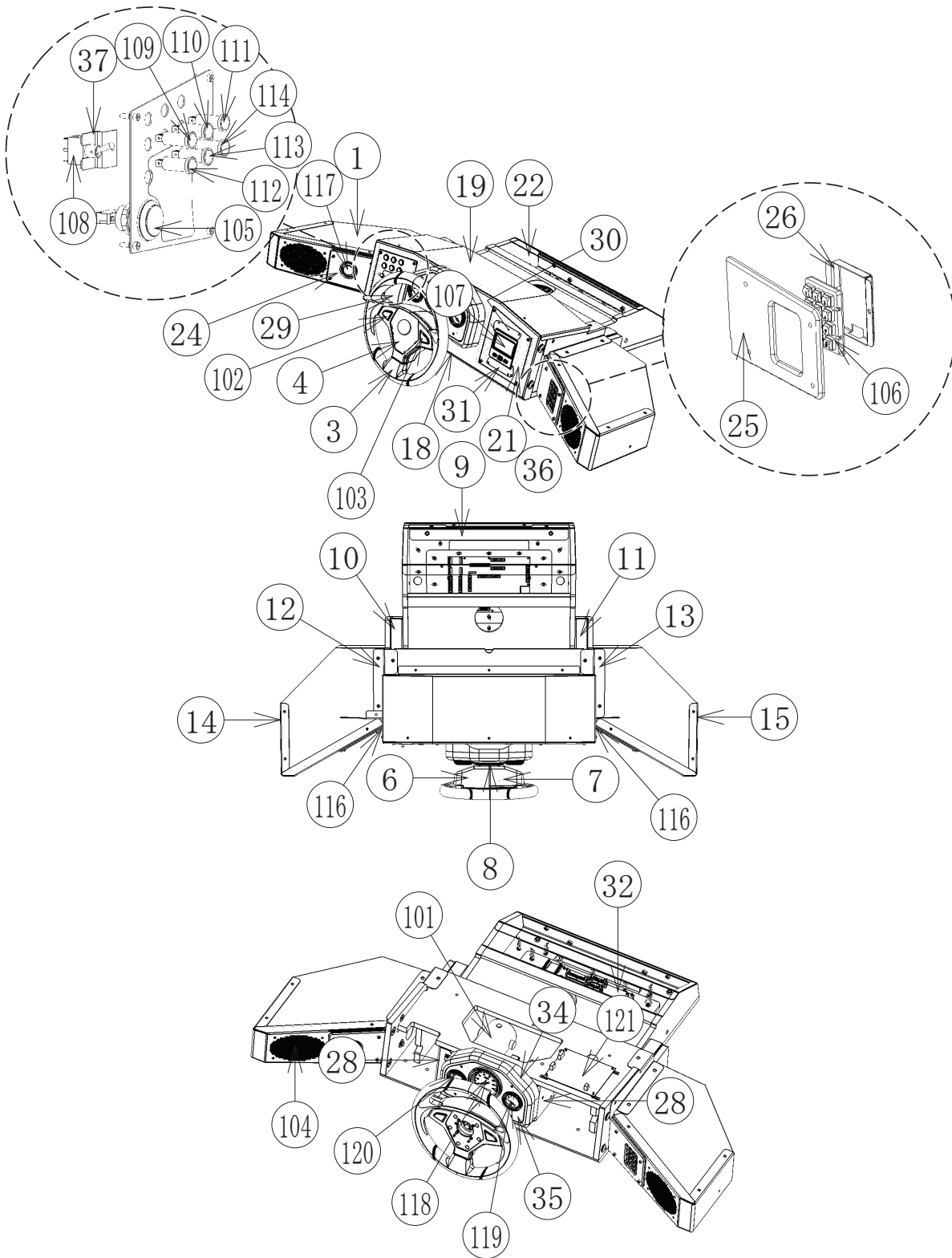

16 ASSY CONTROL PANEL SDX

(D-2/3)

| ITEM NO | PART NO | DESCRIPTION | QTY |
|---------|-----------------|----------------------------------|---------------|
| ***1 | DSD-3201XUK | BASE CTRL PNL | 1 |
| ***3 | RNE-2001 | STEERING WHEEL | 1 |
| ***4 | RNE-2002 | FRONT CENTER COVER | 1 |
| ***5 | RNE-2003 | FRONT COVER | 1 |
| ***6 | RNE-2004 | REAR COVER L | 1 |
| ***7 | RNE-2005 | REAR COVER R | 1 |
| ***8 | RNE-2006 | HANDLE COLLAR CAP | 1 |
| ***9 | DSD-3202UK | BRKT BRACE REAR | 1 |
| ***10 | DSD-3203XUK | BRKT JOINT L | 1 |
| ***11 | DSD-3204XUK | BRKT JOINT R | 1 |
| ***12 | DSD-3205UK | BRKT JOINT WING L | 1 |
| ***13 | DSD-3206UK | BRKT JOINT WING R | 1 |
| ***14 | DSD-3207XUK | BRKT SPEAKER MTG L | 1 |
| ***15 | DSD-3208XUK | BRKT SPEAKER MTG R | 1 |
| ***18 | DSD-3211XUK | PLATE CTRL PNL FRONT | 1 |
| ***19 | DSD-3212UK | PLATE CTRL PNL LID FRONT | 1 |
| ***20 | DSD-3213XUK | PLATE BTN L | 1 |
| ***21 | DSD-3214XUK | PLATE BTN R | 1 |
| ***22 | DSD-3215XUK | PLATE CTRL PNL LID REAR | 1 |
| ***23 | | | 2 |
| ***24 | DSD-3217UK | PLATE MOTION STOP SURROUND | 1 |
| ****1 | DSD-3217-AUK | PLATE MOTION STOP SURROUND BLANK | 1 |
| ***25 | DSD-3218UK | PLATE KEYPAD SURROUND | 1 |
| ****1 | DSD-3218-AUK | PLATE KEYPAD SURROUND BLANK | 1 |
| ***26 | DSD-3219UK | BRKT KEYPAD BASE | 1 |
| ***27 | | | 2 |
| ***28 | DSD-3221UK | BRKT MECHA MTG | 2 |
| ***29 | DSD-3222UK | DECAL START/VIEW | 1 |
| ****1 | DSD-3222-AUK | DECAL START/VIEW BLANK | 1 |
| ***30 | DSD-3223UK | STICKER RADIO TOP | 1 |
| ***31 | DSD-3224UK | STICKER RADIO BTM | 1 |
| ***32 | DSD-4100UK | ASSY ELEC COCKPIT | 1 |
| ***33 | RD-1218UK | COVER FOOTWELL LIGHT | 1 |
| ***34 | DSD-3231UK | ENCLOSURE DIALS | 1 |
| ***35 | DSD-3232UK | PLATE FRONT DIALS | 1 |
| ***36 | DSD-3225UK | PLATE RETAIN DISP USB | (107)-2 |
| ***37 | DSD-3226UK | BRKT LOCK TOGGLE SW | 1 |
| ***101 | RD-2500UK | MECHA 50-0102-08 W/SEGA SHAFT | 1 |
| ***102 | 509-6218-01 | SW PB 1M W/LED RGB BOOST L RNE | 1 |
| ***103 | 509-6219-01 | SW PB 1M W/LED RGB BOOST R RNE | 1 |
| ***104 | 130-04030-E | SPKR ELIP 4OHM 30W VIS DX4x6P | 2 |
| ***105 | 509-6006-G | BTN CHROME GRN HALO | START |
| ***106 | EP1438 | KEYPAD METAL 12 KEY ALPHA/NUM | 1 |
| ***107 | 200-6003-STM | DISP USB 5103-100 STORM | 1 |
| ***108 | EP1447 | TOGGLE SWITCH | 1 |
| ***109 | EP1441 | L1252 OIL LAMP | PUSH FIT |
| ***110 | EP1442 | L1250 HEADLIGHT LAMP | PUSH FIT |
| ***111 | EP1443 | L1249 BRAKES LAMP | PUSH FIT |
| ***112 | EP1444 | L1242 INDICATORS LAMP | PUSH FIT |
| ***113 | EP1445 | L1245 HAZARD LAMP | PUSH FIT |
| ***114 | EP1446 | L1246 FAN LAMP | PUSH FIT |
| ***115 | 390-2012-020RGB | LED FLX STRIP RGB 12V 20CM | FOOTWELL |
| ***116 | 390-2112-010WUK | LED STRIP RIGID 12V 10CM | CTRL PNL SIDE |
| ***117 | 509-6002-R | BTN RND 44MM 12V RED 22-2070-2 | MOTION STOP |

| ITEM NO | PART NO | DESCRIPTION | QTY |
|---------|---------------|-------------------------------|----------------------------------------------------|
| ***118 | EP1450 | GAUGE SPEEDO DOLPHIN | 1 |
| ***119 | EP1451 | GAUGE FUEL DOLPHIN | 1 |
| ***120 | EP1452 | GAUGE VOLT DOLPHIN | 1 |
| ***121 | FR-838-001UK | MOTOR CONT HAPP 50-2000-03 | 1 |
| ***122 | OS1230 | FOAM STRIP 2MM X 10MM | (106)-0.1M 0.1 |
| ***123 | OS1011 | PCB FEET | (118)-4 4 |
| ***124 | 280-A01264-WX | ROUTER TWIST D12 SO6.4 WOOD X | 2 |
| ***201 | 020-000820 | M8X20 BLT PAS | (3)-1 (USE ANAEROBIC RETAINER) 1 |
| ***202 | 060-S00800-0B | M8 WSHR SPR BLK | (3)-1,(9)-2,(10)-2,(11)- 2,(34)-2 9 |
| ***203 | 030-000620 | M6X20 BLT PAS | (28)-3,(101)-4 10 |
| ***204 | 068-652016 | M6 WSHR 20OD FLT PAS | (14)-1,(15)-1,(101)-8 6 |
| ***205 | 060-S00600 | M6 WSHR SPR PAS | (14)-1,(15)-1,(28)- 3,(101)-4 12 |
| ***206 | 060-F01600 | M16 WSHR FORM A FLT PAS | under (207) 2 |
| ***207 | 068-852515-0B | M8 WSHR 25OD FLT BNP | (3)-3 SPG-2039 RE- PLACEMENT 3 |
| ***208 | 020-000316-0Z | M3X16 SKT CAP 0Z | (4)-4 4 |
| ***209 | 000-P00308 | M3X8 MSCR PAN PAS | (5)-3 3 |
| ***210 | 060-F00300 | M3 WSHR FORM A FLT PAS | (5)-3,(6)-3,(7)-3 9 |
| ***211 | 060-S00300 | M3 WSHR SPR PAS | (5)-3,(6)-3,(7)-3 9 |
| ***212 | 000-P00310 | M3X10 MSCR PAN PAS | (6)-3,(7)-3 6 |
| ***213 | 029-B00416-0B | M4X16 SKT BH BLK | (8)-2,(14)-4,(15)-4,(19)- 6,(33)-2 18 |
| ***214 | 060-S00400-0B | M4 WSHR SPR BLK | (8)-2,(14)-4,(15)-4,(19)-6 16 |
| ***215 | 068-441616-0B | M4 WSHR 16OD FLT BLK | (8)-2,(14)-4,(15)-4,(19)- 6,(32)-2,(35)-4 22 |
| ***216 | 020-000830-0Z | M8X30 SKT CAP OZ | (9)-2,(10)-2,(11)-2,(34)-2 8 |
| ***217 | 068-852216-0B | M8 WSHR 22OD FLT BLK | (9)-2,(10)-2,(11)-2,(18)- 4,(34)-2 12 |
| ***218 | 029-B00620-0B | M6X20 SKT BH BLK | (12)-4,(13)-4,(22)-2 10 |
| ***219 | 060-S00600-0B | M6 WSHR SPR BLK | (12)-4,(13)-4,(22)-2 10 |
| ***220 | 029-B00820-0B | M8X20 SKT BH BLK | (18)-4 4 |
| ***221 | 020-0S0416 | M4X16 SKT CAP STNLS | (20)-4,(21)-4,(24)-4,(25)- 4 16 |
| ***222 | 050-F00400 | M4 NUT FLG SER PAS | (26)-2,(35)-4 6 |
| ***223 | 029-B00430-0B | M4X30 SKT BH BLK | (32)-2 2 |
| ***224 | 050-U00400 | M4 NUT NYLOK PAS | (104)-4 4 |
| ***225 | 060-F00400 | M4 WSHR FORM A FLT PAS | (104)-4 4 |
| ***226 | 012-P03506-F | N6x1/4" S/TAP FLG PAS | (118)-4 4 |
| ***227 | 030-000630 | M6X30 BLT PAS | (14)-1,(15)-1 2 |
| ***228 | 050-F00300 | M3 NUT FLG SER PAS | (36)-2 4 |
| ***301 | RNE-60104 | WH STEERING WHEEL EXT | 1 |
| ***302 | RNE-60105 | WH STEERING BUTTON | 1 |
| ***305 | DSD-60010UK | WH PEDALS | 1 |
| ***312 | DSD-60024UK | WH MOTION STOP | 1 |

⑰ ASSY AC UNIT (DSD-3350UK)

(D-1/1)

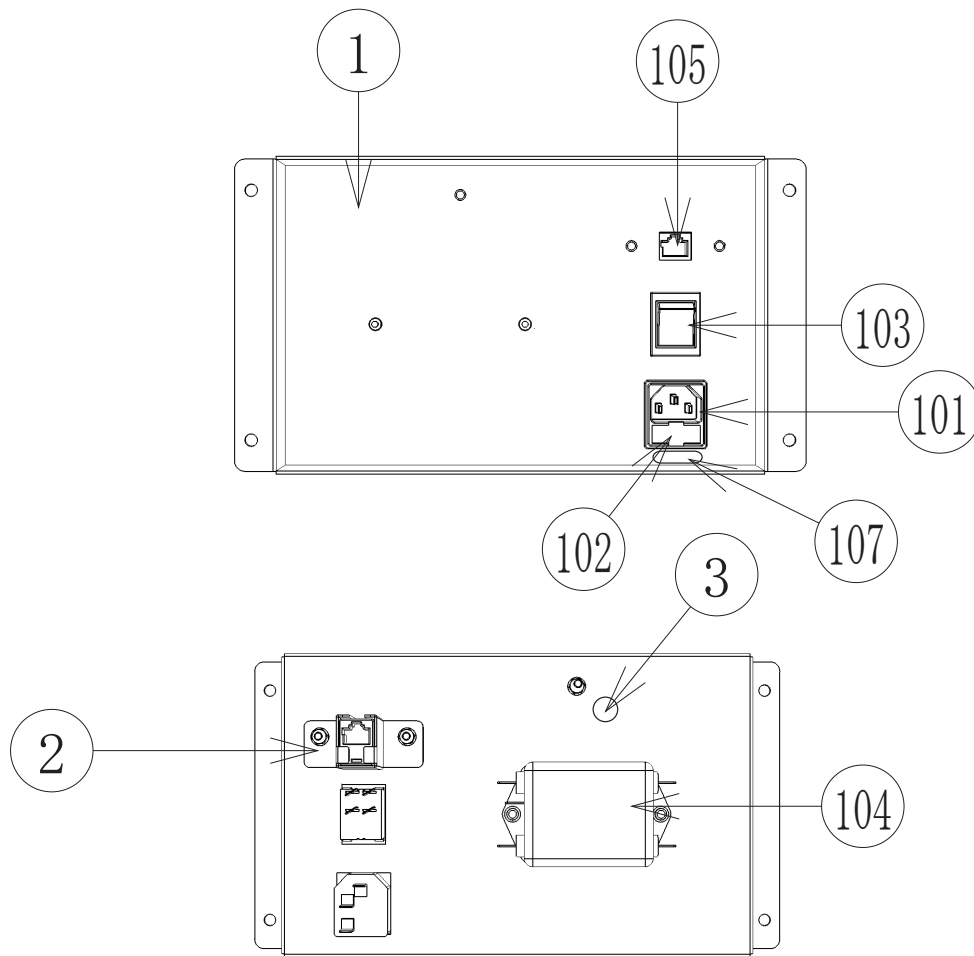

| ITEM NO | PART NO | DESCRIPTION | QTY |
|---------|---------------|------------------------------|----------------|
| ***1 | RD-1541UK | AC BRKT | 1 |
| ***2 | TFF-0402UK | CONN COVER | 1 |
| ***3 | LB1096 | STICKER PROTECTIVE EARTH | 1 |
| ***101 | EP1302 | EUROSOCKET FUSED 10A 250VAC | 1 |
| ***102 | 514-5078-5000 | FUSE 5X20 CERAMIC SB 5000mA | 2 |
| ***103 | SW1109 | SWITCH ROCKER 250V AC | 1 |
| ***104 | EP1419 | FILTER SCHAFFNER 2030-16-06 | 1 |
| ***105 | EP1391 | COUPLER INLINE LAN RJ45 | 1 |
| ***106 | 310-5029-D508 | HEAT SHRINK SLEEVING 50.8DIA | (102)-4 |
| ***107 | LB1126-5-250 | FUSE LABEL 5A 250V | 1 |
| | | | 2 |
| ***201 | 000-P00308 | M3X8 MSCR PAN PAS | (104)-2 |
| ***202 | 060-F00300 | M3 WSHR FORM A FLT PAS | (104)-2 |
| ***203 | 060-S00300 | M3 WSHR SPR PAS | (104)-2 |
| ***204 | 050-F00400 | M4 NUT FLG SER PAS | (2)-2, 2-EARTH |
| ***301 | | | 1 |
| ***302 | 600-9060-44K | WH EARTH 60CM M4/M4 K | 1 |

⑱ ASSY HEADER LIGHT (DSD-3370UK)

(D-1/1)

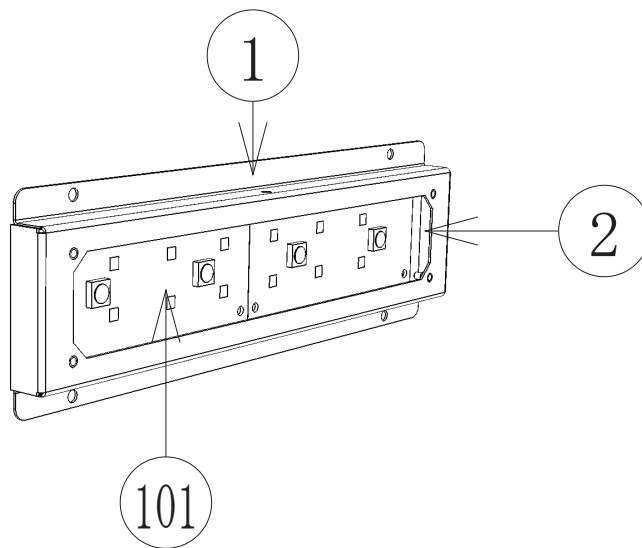

| ITEM NO | PART NO | DESCRIPTION | QTY |
|---------|------------|------------------------|--------------------|
| ***1 | DSD-3371UK | ENCLOSURE LIGHT | 1 |
| ***2 | DSD-3372UK | WINDOW DOWNLIGHT | 1 |
| ***101 | 838-0028UK | XXXX | move assembly 1 |
| ***201 | 050-U00300 | M3 NUT NYLOK PAS | (2)-4 4 |
| ***202 | 060-F00300 | M3 WSHR FORM A FLT PAS | (2)-4 4 |
| ***203 | 000-P00308 | M3X8 MSCR PAN PAS | (2)-2 2 |

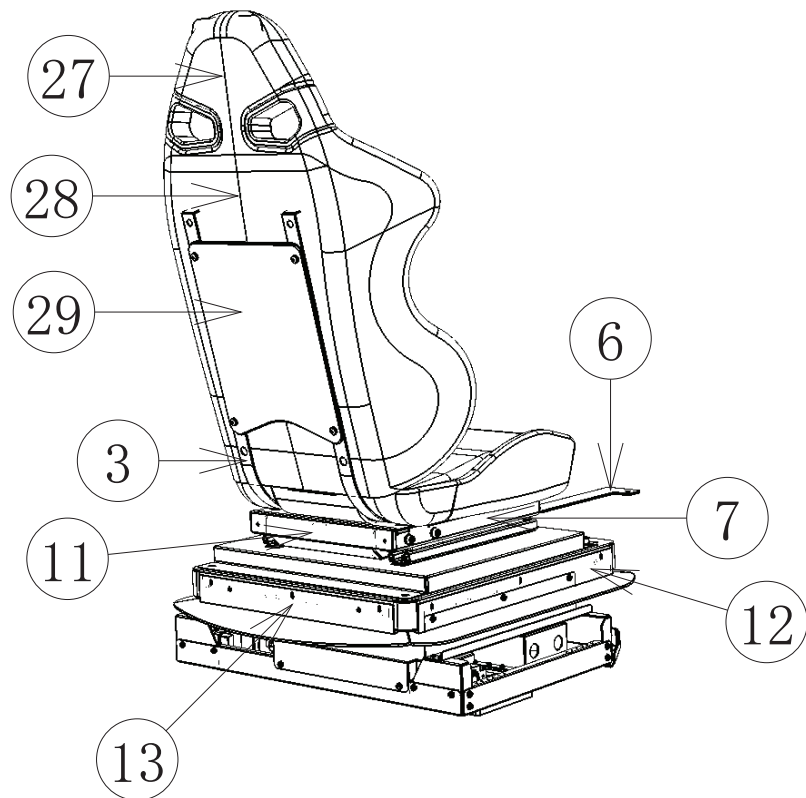
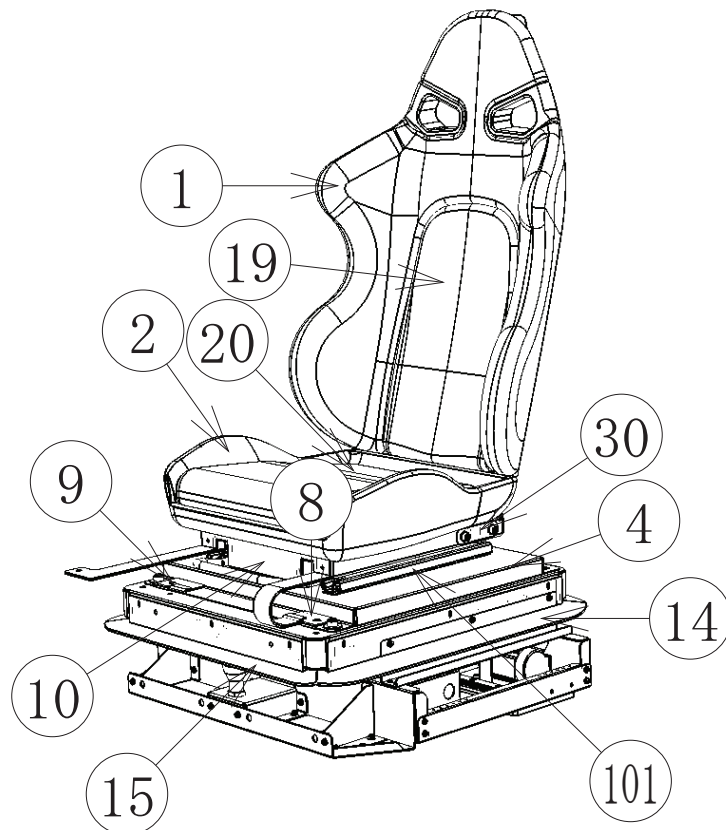

| ITEM NO | PART NO | DESCRIPTION | QTY |
|---------|---------------|--------------------------------------------------------------------------|-----|
| ***1 | SPG-2401-A | UPPER SEAT BLANK | 1 |
| ***2 | SPG-2402-A | LOWER SEAT BLANK | 1 |
| ***3 | DSD-3402UK | SEAT FRAME | 2 |
| ***4 | DSD-3403UK | SEAT BASE | 1 |
| ***5 | DSD-3404UK | BRKT CABLE BEAR LOWER (SEAT BELT OPTION) | 1 |
| ***6 | DSD-3405UK | PROTECT RUBBER | 2 |
| ***7 | DSD-3406UK | SEAT MOUNT TRAY | 1 |
| ***8 | DSD-3407UK | RUBBER HOLDER L | 1 |
| ***9 | DSD-3408UK | RUBBER HOLDER R | 1 |
| ***10 | DSD-3411UK | TRAY COVER FRONT | 1 |
| ***11 | DSD-3412UK | TRAY COVER REAR | 1 |
| ***12 | DSD-3413UK | BRKT GUARD PLATE SIDE | 2 |
| ***13 | DSD-3414UK | BRKT GUARD PLATE FRONT-BACK | 2 |
| ***14 | DSD-3415UK | GASKET GUARD SIDE | 2 |
| ***15 | DSD-3416UK | GASKET GUARD FRONT | 1 |
| ***16 | DSD-3417UK | GASKET GUARD REAR | 1 |
| ***19 | SPG-2401-BUK | UPPER SEAT INSERT | 1 |
| ***20 | SPG-2402-BUK | LOWER SEAT INSERT | 1 |
| ***21 | RD-1603UK | BRKT CABLE BEAR UPPER (SEAT BELT OPTION) | 1 |
| ***25 | DSD-3421UK | BRKT CLOSING GULL HOLES | 1 |
| ***26 | | (STICK-ON) | 2 |
| ***27 | DSD-3423UK | STICKER SEAT HEADER (1)-1 | 1 |
| ***28 | DSD-3424UK | STICKER SEAT SHOULDER (25)-1 | 1 |
| ***29 | DSD-3425UK | PLATE SEAT BACK | 1 |
| ***30 | DSD-3426UK | PLATE SEAT BELT BLANK (NO SEAT BELT OPTION) | 1 |
| ***101 | 601-0006UK | SEAT SLIDE COBRA SEATS SUBFR07 | 1 |
| ***102 | 601-6981-009 | CABLE BEAR L=009 (SEAT BELT OPTION) | 1 |
| ***103 | | (SEAT BELT OPTION) | 1 |
| ***104 | 280-K02529-WX | DRIVE FASTENER 25FH 24L 7.9DIA (19)-8,(20)-10 | 18 |
| ***105 | 280-5297 | SCRIVET 8 1K31 | 6 |
| ***106 | | SHOULDER WSHR (29)-4 | 4 |
| ***201 | 029-B00850-0B | M8X50 SKT BH BLK (1)-4,(2)-4 | 8 |
| ***202 | 060-S00800-0B | M8 WSHR SPR BLK (1)-4,(1)-4,(7)-4,(8)-1,(9)-1,(17/30)-2,(22)-2,(101)-4 | 22 |
| ***203 | 068-852216-0B | M8 WSHR 22OD FLT BLK (1)-4,(2)-4,(8)-1,(9)-1,(101)-4 | 14 |
| ***205 | 060-S00400 | M4 WSHR SPR PAS (5)-2,(21)-2 | 4 |
| ***206 | 068-441616 | M4 WSHR 16OD FLT PAS (5)-2,(21)-2 | 4 |
| ***207 | 050-U00800 | M8 NUT NYLOK PAS (6)-1 | 2 |
| ***208 | 060-F01200 | M12 WSHR FORM A FLT (6)-2 | 4 |
| ***209 | 020-000820-0Z | M8X20 SKT CAP OZ (7)-4,(8)-1,(9)-1,(17/30)-2,(22)-2 | 10 |
| ***210 | 029-B00412-0B | M4X12 SKT BH BLK (5)-2,(10)-2,(11)-2,(12)-3,(13)-3,(18)-2,(21)-2,(103)-1 | 23 |
| ***211 | 060-S00400-0B | M4 WSHR SPR BLK (10)-2,(11)-2,(12)-3,(13)-3,(18)-2,(103)-1 | 19 |
| ***212 | 068-441616-0B | M4 WSHR 16OD FLT BLK (10)-2,(11)-2,(12)-3,(13)-3,(18)-2,(103)-1 | 19 |
| ***213 | 060-F00800-0B | M8 WSHR FORM A FLT BLK (17/30)-2,(22)-2 | 4 |
| ***214 | 029-B00620-0B | M6X20 SKT BH BLK (29)-4 | 4 |
| ***215 | 060-S00600-0B | M6 WSHR SPR BLK (29)-4 | 4 |
| ***216 | 060-F00600-0B | M6 WSHR FORM A FLT BLK (14)-4,(15)-4,(16)-4,(29)-4 | 20 |

19 ASSY SEAT (DSD-3400UK)

(D-3/3)

| ITEM NO | PART NO | DESCRIPTION | | QTY |
|---------|---------------|--------------------------------|----------------------|-----|
| ***217 | 020-000512-0Z | M5X12 SKT CAP OZ | (102)-4 | 4 |
| ***218 | 060-S00500 | M5 WSHR SPR PAS | (102)-4 | 4 |
| ***219 | 068-551616 | M5 WSHR 16OD FLT PAS | (102)-4 | 4 |
| ***223 | 020-000830-0Z | M8X30 SKT CAP OZ | (101)-4 | 4 |
| ***224 | 000-F00408-0B | M4X8 MSCR CSK BLK | (25)-4 | 4 |
| ***225 | 000-F00412 | M4X12 MSCR CSK PAS | (14)-4,(15)-4,(16)-4 | 16 |
| ***301 | DSD-60037UK | WH SEATBELT | | 1 |
| ***302 | 600-9060-44K | WIRE HARN EARTH 600MM M4/M4 K | CABLE BEAR | 1 |
| ***303 | 600-9120-44K | WIRE HARN EARTH 1200MM M4/M4 K | THRU. SLIDE MECHA | 1 |

20 ASSY REAR SPEAKER BOX (DSD-3500XUK)

(D-1/2)

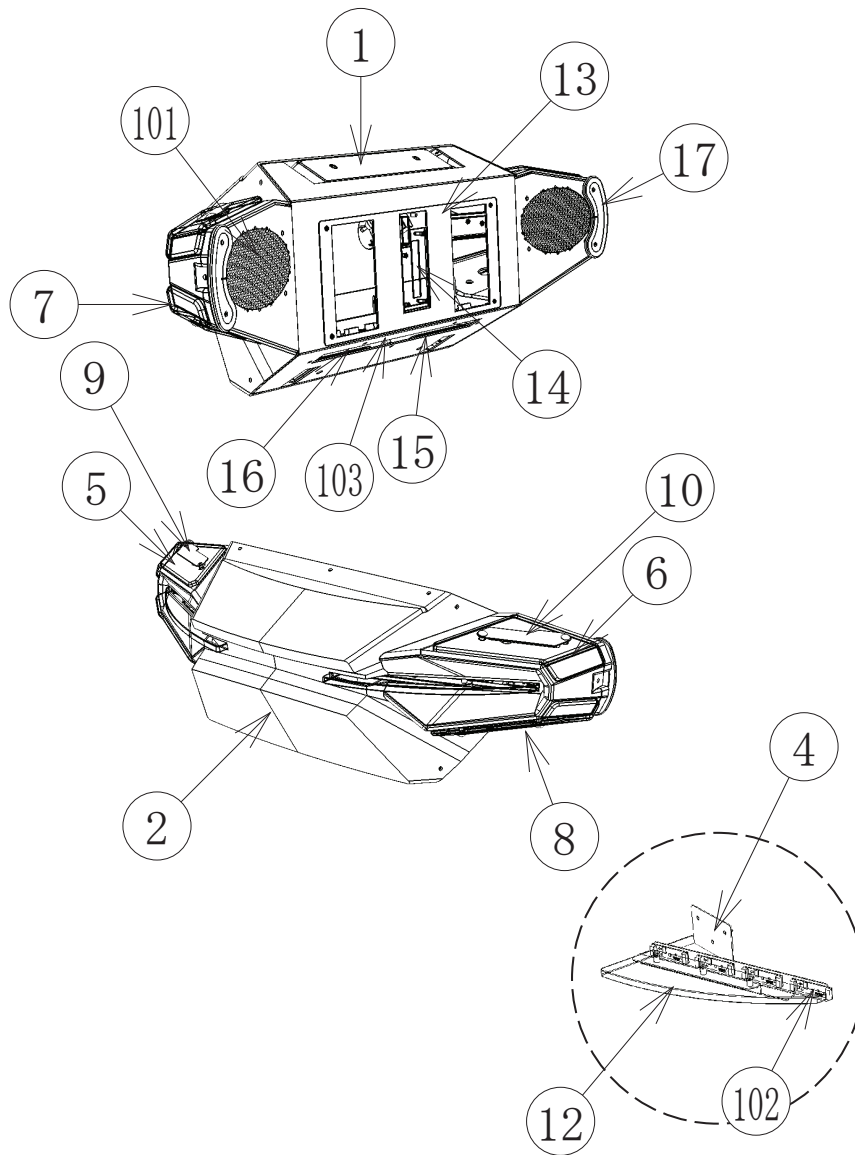

| ITEM NO | PART NO | DESCRIPTION | QTY |
|---------|-------------|----------------------------|----------------|
| ***1 | DSD-3501XUK | BRKT SPEAKER MTG | 1 |
| ***2 | DSD-3502XUK | REAR COVER SPEAKER MOULD | 1 |
| ***3 | DSD-3503XUK | BRKT BRAKE LIGHT MTG L | 1 |
| ***4 | DSD-3504XUK | BRKT BRAKE LIGHT MTG R | 1 |
| ***5 | DSD-3505XUK | PLATE LED LIGHT UPPER L | under (9) |
| ***6 | DSD-3506XUK | PLATE LED LIGHT UPPER R | under (10) |
| ***7 | DSD-3507XUK | PLATE LED LIGHT LOWER L | under (9) |
| ***8 | DSD-3508XUK | PLATE LED LIGHT LOWER R | under (10) |
| ***9 | DSD-3509XUK | PLATE LED LIGHT SECURE L | 2 |
| ***10 | DSD-3510XUK | PLATE LED LIGHT SECURE R | 2 |
| ***11 | | | under (9 & 10) |
| ***12 | DSD-3512XUK | PLATE LED LIGHT MID | 2 |
| ***13 | DSD-3513XUK | PLATE COVER SENSOR MTG | 1 |
| ***14 | DSD-3514XUK | WINDOW STOP SENSOR REAR 02 | 1 |
| ***15 | DSD-3515XUK | BRKT LED RGB MTG | 1 |
| ***16 | DSD-3516XUK | WINDOW DOWNLIGHT | 1 |
| ***17 | DSD-3517XUK | BRKT CORNER PROTECT | 2 |

20 ASSY REAR SPEAKER BOX (DSD-3500XUK)

(D-2/2)

| ITEM NO | PART NO | DESCRIPTION | | QTY |
|---------|-----------------|-------------------------------|------------------------------------------|-----|
| ***101 | 130-04030-E | SPKR ELIP 4OHM 30W VIS DX4x6P | | 2 |
| ***102 | 838-0025UK | SERIAL RGB BOARD | BACKLIGHT | 8 |
| ***103 | 390-2012-020RGB | LED FLX STRIP RGB 12V 20CM | UP-DOWN LIGHTS | 4 |
| ***104 | EP1440 | SENSOR REFLECTIVE 7295154 | | 1 |
| ***105 | 838-0028UK | XXXX | | 1 |
| ***106 | EP1456 | 65 DEG TEMP SWITCH 732-539 | | 1 |
| ***201 | 029-B00412-0B | M4X12 SKT BH BLK | (2)-8,(13)-4 | 12 |
| ***202 | 060-S00400-0B | M4 WSHR SPR BLK | (2)-8,(12)-2,(13)-4 | 16 |
| ***203 | 068-441616-0B | M4 WSHR 16OD FLT BLK | (2)-8,(12)-2,(13)-4,(14)-4,(15)-3,(16)-5 | 28 |
| ***204 | 050-F00400 | M4 NUT FLG SER PAS | (3)-3,(4)-3,(15)-3,(104)-2 | 11 |
| ***205 | 031-000520-0C | M5X20 CRG BLT CRM | (9)-4,(10)-4 | 8 |
| ***206 | 050-F00500 | M5 NUT FLG SER PAS | (9)-4,(10)-4 | 8 |
| ***207 | 050-U00400 | M4 NUT NYLOK PAS | (14)-4,(16)-5,(101)-4 | 17 |
| ***208 | 060-F00400 | M4 WSHR FORM A FLT PAS | (101)-4 | 8 |
| ***209 | 000-P00308 | M3X8 MSCR PAN PAS | (102)-2,(105)-4 | 20 |
| ***210 | 068-330808-PN | M3 WSHR 8OD FLT NYLON | (102)-2,(105)-4 | 20 |
| ***211 | 068-551616-0B | M5 WSHR 16OD FLT BLK | (9)-4,(10)-4 | 8 |
| ***212 | 000-P00408 | M4X8 MSCR PAN PAS | (12)-3 | 6 |
| ***301 | | | | 1 |
| ***302 | DSD-60022UK | WH REAR LIGHTS | | 2 |
| ***303 | | | | 4 |
| ***304 | | | | 1 |
| ***305 | DSD-60020UK | WH REAR STRUTS | | 2 |
| ***306 | DB-60033UK | WH SERIAL LED LINK | | 6 |

21 ASSY SENSOR MOUNTING (DSD-3620UK)

(D-1/1)

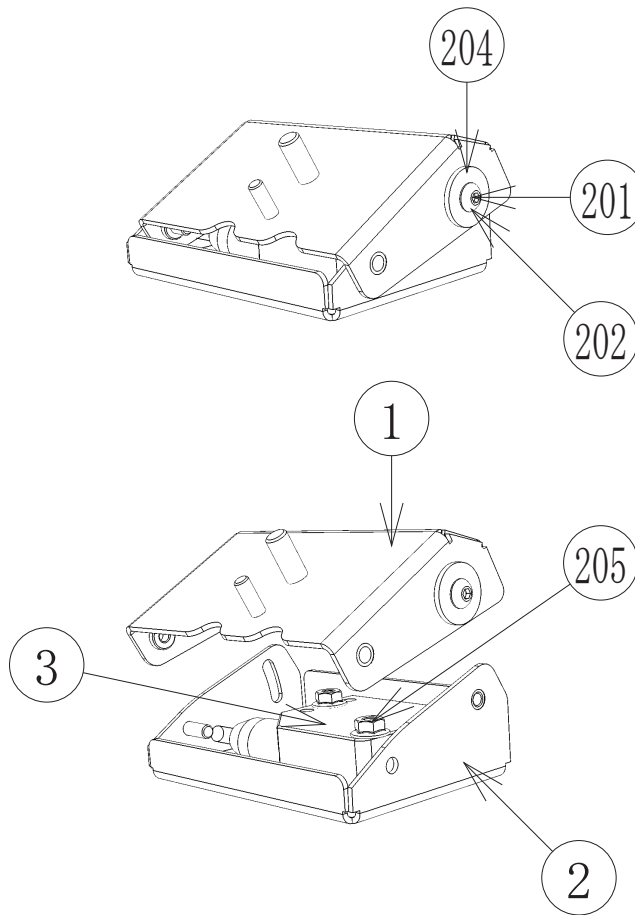

| ITEM NO | PART NO | DESCRIPTION | | QTY |
|---------|---------------|---------------------------|---------|-----|
| ***1 | DSD-3621XUK | BRKT SENSOR TOP | | 1 |
| ***2 | DSD-3622XUK | BRKT SENSOR BTM | | 1 |
| | | | | |
| ***101 | EP1440 | SENSOR REFLECTIVE 7295154 | | 1 |
| ***102 | 601-0460-0W | CABLE TIE 100mm WHITE | | 1 |
| | | | | |
| ***201 | 029-B00412-0B | M4X12 SKT BH BLK | (2)-3 | 3 |
| ***202 | 060-S00400-0B | M4 WSHR SPR BLK | (2)-2 | 2 |
| ***203 | 060-F00400-0B | M4 WSHR FORM A FLT BLK | (2)-1 | 1 |
| ***204 | 068-441616-0B | M4 WSHR 16OD FLT BLK | (2)-2 | 2 |
| ***205 | 050-U00400 | M4 NUT NYLOK PAS | (101)-2 | 2 |

②② ASSY SUB WOOFER (DSD-3800XUK)

(D-1/1)

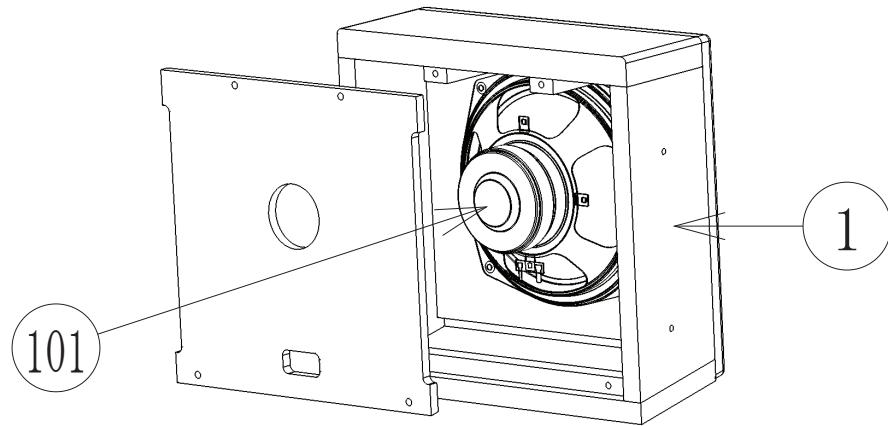

| ITEM NO | PART NO | DESCRIPTION | QTY |
|---------|---------------|--------------------------|---------|
| ***1 | DSD-3801XUK | BOX WOOFER | 1 |
| ***101 | 130-020-04080 | SPEAKER 4 OHM 80W WS 20E | 1 |
| ***102 | | | 1 |
| ***201 | 012-P00410-F | N8X3/8" S/TAP FLG PAS | (101)-4 |
| ***301 | DSD-60023UK | WH WOOFER EXTN | 1 |

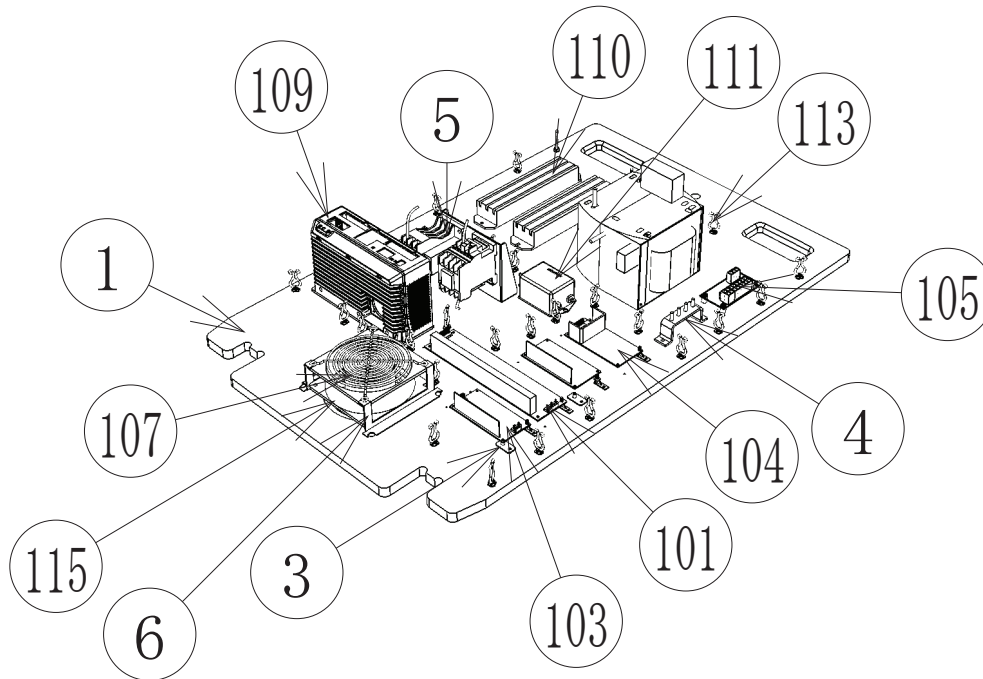

ITEM NO PART NO DESCRIPTION QTY

| | | | |
|--------|----------------|------------------------------------|---------------------------------|
| ***1 | DSD-4001XUK | WOODEN BASE MAIN BD | 1 |
| ***2 | | | 1 |
| ***3 | DSD-4002UK | PLATE PSU POST | 3 |
| ***4 | CFB-4003-01UK | EARTH PLATE | 1 |
| ***5 | DSD-4050XUK | ASSY THERM MAG PSU | 1 |
| ***6 | 105-5340-01 | FAN BRKT LONG | 2 |
| ***101 | 400-075-024-01 | PSU 24VDC 75W MW LPS-75-24 | 1 |
| ***102 | | | 1 |
| ***103 | 400-150-012-03 | PSU 12VDC 150W MW EPP-150-12 | 2 |
| ***104 | 400-065-005 | PSU 5VDC 65W MW EPS-65-5 | 1 |
| ***105 | 838-14551-02UK | AC DISTRIBUTION BD | 1 |
| ***106 | | | 1 |
| or | | US Build Only (IAAPA) | 1 |
| ***107 | FN1012 | FAN GUARD METAL 120MM (FG-12) | 2 |
| ***108 | 837-15348 | IC BD USB TO ISOLATION RS485 | 1 |
| ***109 | | THC UNIT | 1 |
| ***110 | | RESISTOR | 2 |
| ***111 | EP1453 | FILTER SCHAFFNER FN2060-16-06 | 1 |
| ***112 | OS1011 | PCB FEET | (101)-3,(102)-3,(103)-3,(104)-4 |
| ***113 | 280-A01264-WX | ROUTER TWIST D12 SO6.4 WOOD X | 25 |
| ***114 | EP1393 | FERRITE TDK ZCAT3035-1330 | 1 |
| ***115 | 260-0012-01UK | FAN DC 12V RoHS EEC0381B1-000U-A99 | 1 |
| ***201 | 012-P00410-F | N8X3/8" S/TAP FLG PAS | (2)-4,(107)-4,(110)-2,(111)-2 |
| ***202 | 068-441616 | M4 WSHR 160D FLT PAS | (2)-4.(5)-2,(106)-4 |

| ITEM NO | PART NO | DESCRIPTION | | QTY |
|---------|--------------|------------------------|-------------------------------|-----|
| ***203 | 012-P03512-F | N6x1/2" S/TAP FLG PAS | (3)-1,(4)-2,(112)-13 | 18 |
| ***204 | 000-P00416 | M4X16 MSCR PAN PAS | (5)-2,(106)-4,(109)-4 | 10 |
| ***205 | 060-S00400 | M4 WSHR SPR PAS | (5)-2,(106)-4,(109)-4 | 10 |
| ***206 | | | (5)-2,(106)-4 | 6 |
| ***207 | 012-P00325 | N4X1" S/TAP PAN PAS | (105)-4,(108)-4 | 8 |
| ***208 | 060-F00400 | M4 WSHR FORM A FLT PAS | (109)-4 | 4 |
| ***209 | 000-P00308 | M3X8 MSCR PAN PAS | (101)-1,(102)-1,(103)-1 | 3 |
| ***210 | 060-S00300 | M3 WSHR SPR PAS | (6)-2,(101)-1,(102)-1,(103)-1 | 7 |
| ***211 | 060-F00300 | M3 WSHR FORM A FLT PAS | (6)-2,(101)-1,(102)-1,(103)-1 | 7 |
| ***212 | 000-P00312 | M3X12 MSCR PAN PAS | (6)-2 | 4 |
| ***301 | DSD-60002UK | WH AC 230V AC DIST | | 1 |
| ***302 | DSD-60003UK | WH 100V TO XFMR | | 1 |
| ***303 | DSD-60004UK | WH DC DIST | | 1 |
| ***304 | DSD-60031UK | WH AC 100V DIST | | 1 |
| ***305 | DSD-60040UK | WH 5V TO RS485 | | 1 |

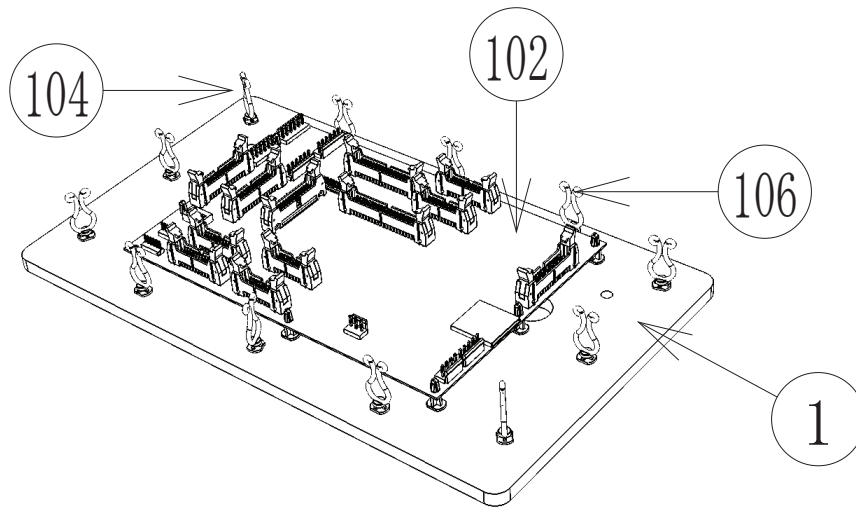

| ITEM NO | PART NO | DESCRIPTION | | QTY |
|----------|-----------------|-------------------------------|---------|------|
| ****1 | DSD-4101UK | WOODEN BASE ELEC COCKPIT BD | NM | 1 |
| ****101 | | | | 1 |
| ****102 | 838-0030UK | RED TWO PCB | | 1 |
| ****103 | 838-0027UK | AMP 5.1 40W KEENE | move | 1 |
| ****104 | 280-L00640-WX | STANDOFF 6MM 4 HOLE | (102)-8 | 8 |
| ****105 | OS1011 | PCB FEET | (103)-4 | 4 |
| ****106 | 280-A01264-WX | ROUTER TWIST D12 SO6.4 WOOD X | | 16 |
| ****201 | 012-P03506-F | N6x1/4" S/TAP FLG PAS | (103)-4 | 4 |
| ****303 | DSD-60008UK | WH P PORT B | | 1 |
| ****304 | DSD-60009UK | WH MOTOR CONTROL | | 1 |
| ****306 | DSD-60011UK | WH DC DIST B | | 1 |
| ****307 | DSD-60013UK | WH RED ONE | | 1 |
| ****308 | DSD-60014UK | WH BUTTONS | | 1 |
| ****314 | DSD-60029UK | WH KEYPAD | | 1 |
| ****315 | DSD-60033UK | WH SPEAKERS FRONT | | 1 |
| ****316 | DSD-60034UK | WH L & R SENSORS | | 1 |
| ****317 | DSD-60035UK | WH COIN TOWER | | 1 |
| ****318 | DSD-60036UK | WH SPEAKERS B | | 2 |
| ****319 | BE-6001UK | ASSY LED CLIP | | 1 |
| *****101 | EP1427 | 4 WAY JST SMP-04V-BC | | 1 |
| *****102 | EP1428 | TERM-JST SHF-001T-0.BS | | 4 |
| *****301 | RND-60059 | WH LED CLIP SUZO QL0129 | | 1 |
| ****320 | 600-7919-150UK | WH ST JACK TO PHONO | | 3 |
| ****321 | DSD-60046UK | WH CENTRE SPEAKER | | 1 |
| ****322 | DSD-6001UK | ASSY LED WHITE 80MM | | 2 |
| *****101 | 390-2112-008WUK | LED RIGID WHITE 80mm | | 1 |
| *****102 | OS1248 | TAPE DS 12mm X 10mm 0.08M | | 0.08 |
| *****301 | DB-60030UK | WH LED WHITE | | 1 |

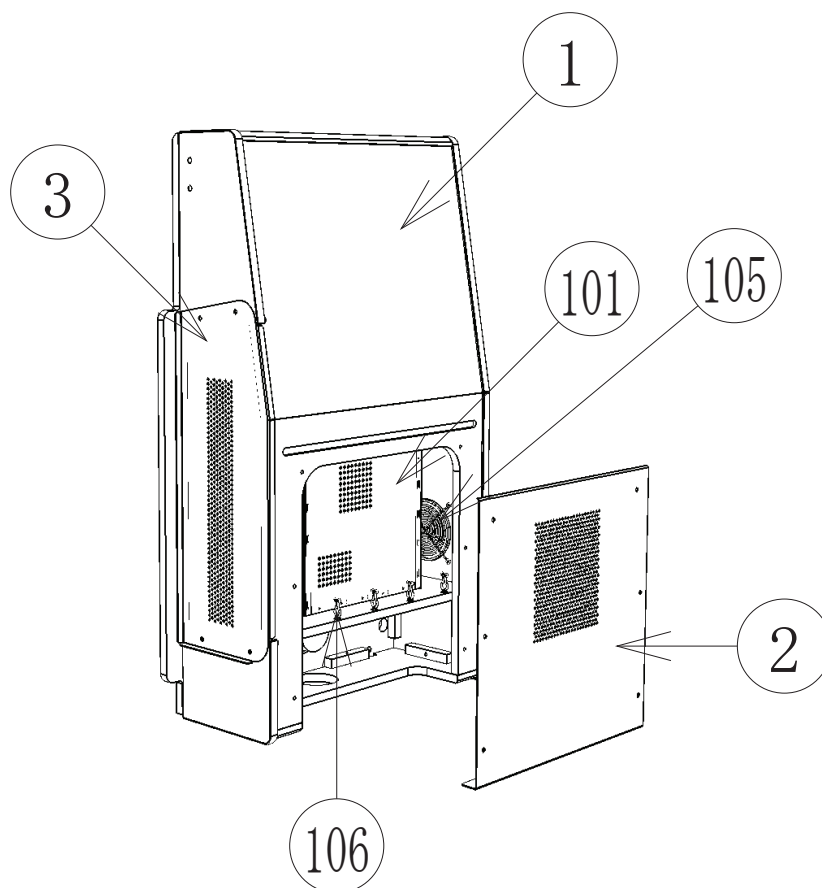

| ITEM NO | PART NO | DESCRIPTION | QTY |
|---------|---------------|-------------------------------|---------------------------|
| ***1 | DSD-4201UK | WOODEN BOX GAMEBOARD | 1 |
| ***2 | DSD-4202UK | COVER GAMEBD REAR | 1 |
| ***3 | DSD-4203UK | COVER GAMEBD SIDE ACCESS | 1 |
| ***4 | DSD-4204UK | BRKT GAMEBD RETAINER | 1 |
| ***5 | | | 2 |
| ***101 | 610-0010-01UK | ASSY PC SD | 1 |
| ***105 | FN1012 | FAN GUARD METAL 120MM (FG-12) | 2 |
| ***106 | 280-A01264-WX | ROUTER TWIST D12 SO6.4 WOOD X | 8 |
| ***201 | 029-B00416-0B | M4X16 SKT BH BLK | (2)-6,(3)-4,(4)-3,(101)-2 |
| ***202 | 060-S00400-0B | M4 WSHR SPR BLK | (2)-6,(3)-4,(4)-3,(101)-2 |
| ***203 | 068-441616-0B | M4 WSHR 16OD FLT BLK | (2)-6,(3)-4,(4)-3,(101)-2 |
| ***204 | | | (5)-2 |
| ***205 | | | (5)-2 |
| ***206 | 012-P00410-F | N8X3/8" S/TAP FLG PAS | (105)-4 |
| ***301 | DSD-60007UK | WH P PORT A | 1 |
| ***302 | DSD-60005UK | WH 230V TO PROJECTOR | 1 |

26 ASSY INLET OUTLET SW UNIT SDX

(D-1/1)

| ITEM NO | PART NO | DESCRIPTION | | QTY |
|---------|---------------|------------------------------|---------|-----|
| ***1 | DSD-5751UK | BRKT INLET OUTLET SW | | 1 |
| ***101 | EP1302 | EUROSOCKET FUSED 10A 250VAC | PUSH IN | 1 |
| ***102 | 514-5078-5000 | FUSE 5X20 CERAMIC SB 5000mA | | 1 |
| ***103 | SW1109 | SWITCH ROCKER 250V AC | PUSH IN | 1 |
| ***104 | EP1458 | IEC x4 POWER BLOCK 261-5014 | | 1 |
| ***105 | EP1459 | 1M IEC C14 PLUG TO UK SOCKET | | 1 |
| ***201 | 000-P00308 | M3X8 MSCR PAN PAS | (104)-2 | 2 |
| ***202 | 060-F00300 | M3 WSHR FORM A FLT PAS | (104)-2 | 2 |
| ***203 | 050-F00400 | M4 NUT FLG SER PAS | 1-EARTH | 1 |
| ***301 | DSD-60230UK | WH POWER BLOCK | | 1 |

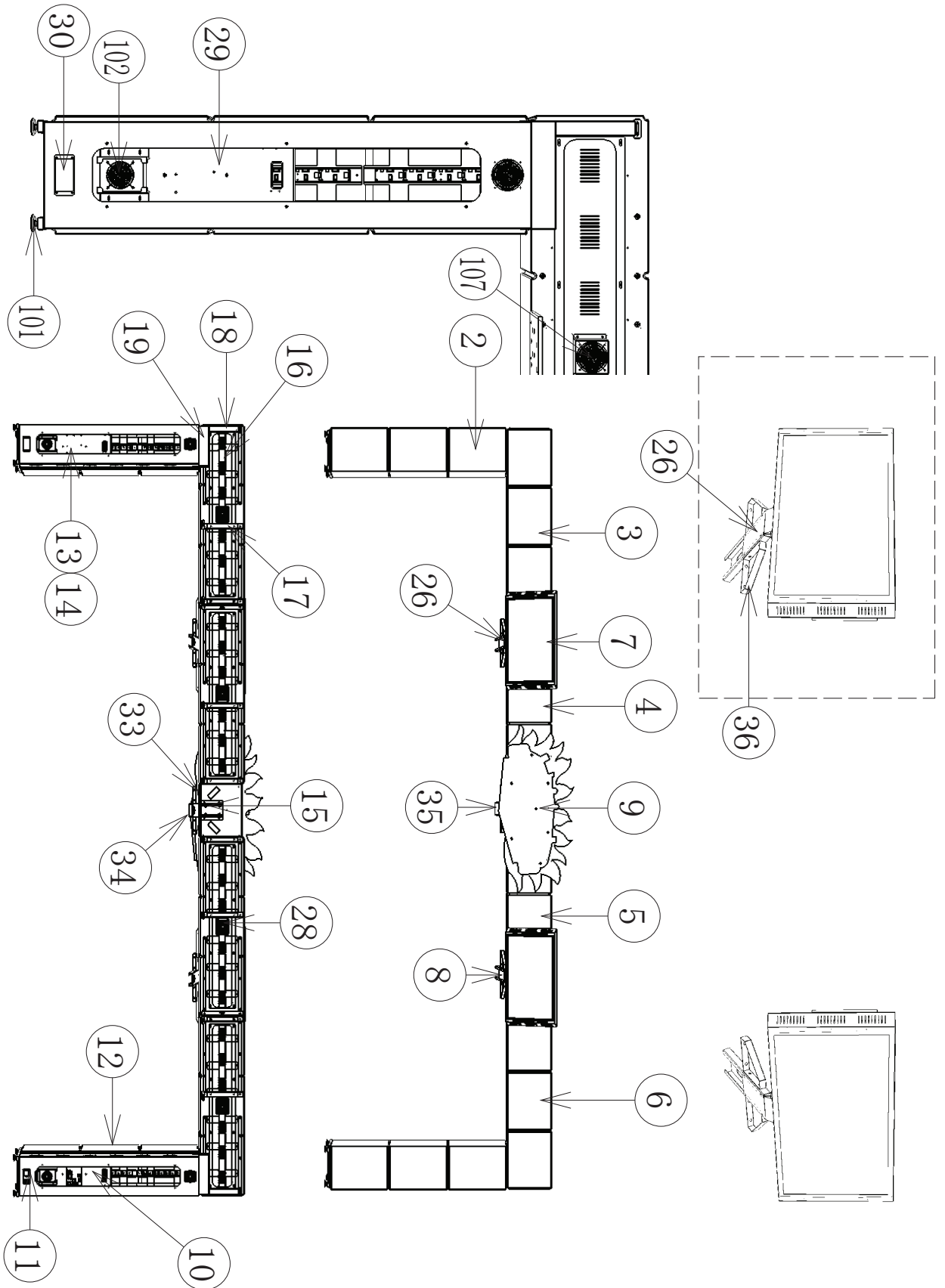

| ITEM NO | PART NO | DESCRIPTION | | QTY |
|---------|---------------|-------------------------------|------------------------------------------------------------|-----|
| *1 | DSD-5010UK | ASSY MARQUEE BLOCK MOUNT | | 4 |
| *2 | DSD-5020UK | ASSY MARQUEE BLOCK UPRIGHT | | 2 |
| *3 | DSD-5025UK | ASSY MARQUEE BLOCK CAB1 | | 1 |
| *4 | DSD-5026UK | ASSY MARQUEE BLOCK CAB2 | | 1 |
| *5 | DSD-5027UK | ASSY MARQUEE BLOCK CAB3 | | 1 |
| *6 | DSD-5028UK | ASSY MARQUEE BLOCK CAB4 | | 1 |
| *7 | DSD-5100UK | ASSY 42" LED DISPLAY | | 2 |
| *8 | DSD-5120UK | ASSY LED DISPLAY MOUNT | | 2 |
| *9 | DSD-5200UK | ASSY MARQUEE BILLBOARD | | 1 |
| *10 | DSD-5400UK | ASSY MARQUEE ELEC BOARD LH | | 1 |
| *11 | DSD-5700UK | ASSY AC SWITCH | | 2 |
| *12 | DSD-5001UK | FRAME UPRIGHT MARQUEE | | 2 |
| *13 | DSD-5002UK | COVER MARQUEE ELEC | | 2 |
| *14 | DSD-5003UK | PANEL MARQUEE ELEC ACCESS | | 2 |
| *15 | DSD-5750UK | ASSY INLET OUTLET SW UNIT | | 1 |
| *16 | DSD-5006UK | PLATE BLOCK REAR COVER | | 4 |
| *17 | DSD-5008XUK | BRKT BLOCK JOINTING | | 2 |
| *18 | DSD-5009UK | COVER BLOCK WIRE | | 2 |
| *19 | DSD-5014UK | COVER FRAME WIRE | | 2 |
| *25 | DSD-5030UK | MOUNT LED ASSY CABI | | 3 |
| *26 | DSD-5031UK | COVER LED MOUNT WIRE | | 2 |
| *28 | DSD-5040UK | ASSY BLOCK FAN | | 4 |
| *29 | DSD-5410UK | ASSY MARQUEE ELEC BOARD RH | | 1 |
| *30 | DSD-5034UK | PLATE MAINS IN BLANKING | | 1 |
| *32 | | | | |
| *33 | DSD-5036UK | BOARD BILLBOARD MOUNT | | 1 |
| *34 | DSD-5037UK | MOUNT BILLBOARD CABI | | 1 |
| *35 | DSD-5038UK | PLATE BILLBOARD MOUNT BLANK | | 1 |
| *36 | DSD-5122UK | BRKT LED ASSY SUPPORT | | 2 |
| | | | | |
| *101 | 601-0004UK-01 | LEG ADJ M16X100x70DIA LNUT | | 8 |
| *102 | FN1012 | FAN GUARD METAL 120MM (FG-12) | | 6 |
| *107 | 260-0012-01UK | FAN DC 12V ROHS | | 2 |
| | | | | |
| *201 | 000-T00616-0B | M6X16 MSCR TH BLK | (14)-6,(16)-8,(27)-2 | 40 |
| *202 | 020-000820-0Z | M8X20 SKT CAP OZ | (8)-4 | 8 |
| *203 | 029-B00412-0B | M4X12 SKT BH BLK | (11)-4,(15)-2,(18)-2,(19)-2,(20)-2,(23)-2,(26)-4,(28)-4 | 42 |
| *204 | 029-B00425-0B | M4X25 SKT BH BLK | (10)-4,(29)-4 | 8 |
| *205 | 029-B00620-0B | M6X20 SKT BH BLK | (3)-4,(4)-4,(5)-4,(6)-4,(13)-6,(17)-2,(18)-1,(21)-2,(22)-2 | 38 |
| *206 | 030-000816 | M8X16 BLT PAS | (1)-5,(7)-4,(8)-2,(9)-4,(25)-8 | 60 |
| *207 | 030-000830 | M8X30 BLT PAS | (25)-4 | 12 |
| *208 | 050-F00400 | M4 NUT FLG SER PAS | (30)-4,(102)-4,(107)-4 | 28 |
| *209 | 050-F00600 | M6 NUT FLG SER PAS | (2)-8,(3)-2,(6)-2,(18)-1 | 22 |

| ITEM NO | PART NO | DESCRIPTION | | QTY |
|---------|-----------------|--------------------------------|---------------------------------------------------------------------------------------|-----|
| *210 | 060-S00400-0B | M4 WSHR SPR BLK | (10)-4,(11)-4,(18)-2,(19)-2,(20)-2,(23)-2,(26)-4,(28)-4,(29)-4 | 48 |
| *211 | 060-S00600-0B | M6 WSHR SPR BLK | (2)-8,(3)-7,(4)-4,(5)-4,(6)-7,(13)-6,(14)-6,(15)-2,(16)-8,(17)-2,(18)-2,(21)-2,(22)-2 | 102 |
| *212 | 060-S00800-0B | M8 WSHR SPR BLK | (1)-5,(7)-4,(8)-6,(9)-4,(25)-12 | 80 |
| *213 | 068-441616-0B | M4 WSHR 16OD FLT BLK | (10)-4,(11)-4,(18)-2,(19)-2,(20)-2,(23)-2,(26)-4,(28)-4,(29)-4,(30)-4 | 52 |
| *214 | 068-652016-0B | M6 WSHR 20OD FLT BLK | (2)-8,(3)-7,(4)-4,(5)-4,(6)-7,(13)-6,(14)-6,(15)-2,(16)-8,(17)-2,(18)-2,(21)-2,(22)-2 | 102 |
| *215 | 068-852216-0B | M8 WSHR 22OD FLT BLK | (1)-5,(7)-4,(8)-6,(9)-4,(25)-12 | 80 |
| *216 | 008-B00450 | M4X50 TMP BH PAS | (107)-4 | 8 |
| *301 | DSD-60224UK | WH AC BLOCK 6 | | 1 |
| *302 | DSD-60221UK | WH DC BLOCK 6 | | 1 |
| *303 | DSD-60222UK | WH CAN LINK 6/5 | | 1 |
| *304 | DSD-60206UK | WH CAN LED LINK | | 2 |
| *305 | DSD-60030UK | WH LED WHT | | 1 |
| *306 | | | | |
| *307 | 600-7014-1000UK | USB ACTIVE EXTN A-A | | 3 |
| *308 | 600-7015-300UK | USB A-A EXTN 300CM USB3 EXT | | 1 |
| *309 | 600-7013-500UK | CA HDMI DVI 500CM 300HDMIDV5 | | 1 |
| *310 | 600-7013-1000UK | CA HDMI DVI 1000CM 300HDMIDV10 | | 1 |
| *311 | 600-7269-0500UK | CA LAN CAT5 500CM | | 4 |

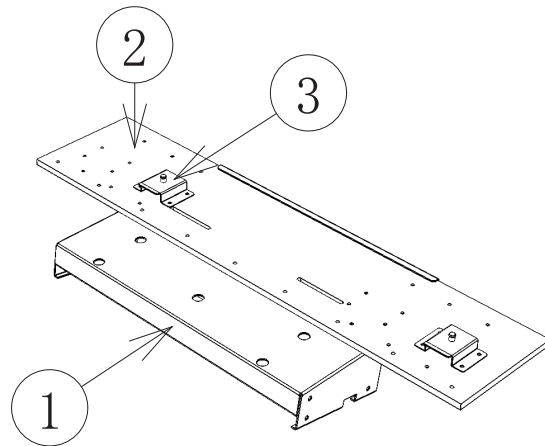

ITEM NO PART NO DESCRIPTION QTY

| | | | | |
|-------|---------------|-----------------------------|-------|---|
| **1 | DSD-5011UK | BRKT MARQUEE BLOCK SUPPORT | | 1 |
| **2 | DSD-5012UK | PANEL MARQUEE BLOCK SUPPORT | | 1 |
| **3 | DSD-5013UK | BRKT BLOCK RETAINING | | 2 |
| | | | | |
| **201 | 029-B00620-0B | M6X20 SKT BH BLK | (3)-4 | 8 |
| **202 | 030-000830-SB | M8X30 BLT W/S BLK | (2)-2 | 2 |
| **203 | 060-S00600-0B | M6 WSHR SPR PAS BLK | (3)-4 | 8 |
| **204 | 060-S00800-0B | M8 WSHR SPR BLK | (2)-2 | 2 |
| **205 | 068-652016-0B | M6 WSHR 20OD FLT BLK | (3)-4 | 8 |
| **206 | 068-852216-0B | M8 WSHR 22OD FLT BLK | (2)-2 | 2 |

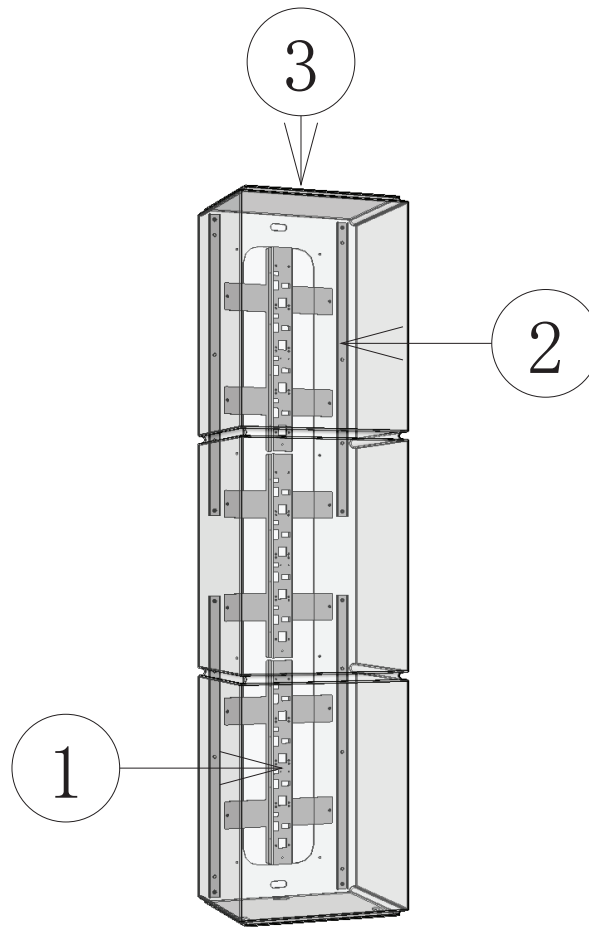

| ITEM NO | PART NO | DESCRIPTION | | QTY |
|---------|---------------|-------------------------|-------|-----|
| **1 | DSD-5021UK | ASSY BLOCK LIGHTING | | 3 |
| **2 | DSD-5017UK | PLATE MARQUEE BLOCK NUT | | 4 |
| **3 | DSD-6005UK | BLOCK MARQUEE | | 1 |
| | | | | |
| **201 | 008-B00416 | M4X16 TMP BH PAS | (1)-4 | 12 |
| **202 | 029-B00620-0B | M6X20 SKT BH BLK | (2)-2 | 8 |
| **203 | 050-F00600 | M6 NUT FLG SER PAS | (2)-1 | 4 |
| **204 | 060-S00400 | M4 WSHR SPR PAS | (1)-4 | 12 |
| **205 | 060-S00600 | M6 WSHR SPR PAS | (2)-3 | 12 |
| **206 | 068-441616 | M4 WSHR 16OD FLT PAS | (1)-4 | 12 |
| **207 | 068-652016 | M6 WSHR 20OD FLT PAS | (2)-3 | 12 |
| | | | | |
| **301 | DSD-60204UK | WH AC BLOCK 1 | | 1 |
| **302 | DSD-60205UK | WH DC BLOCK 1 | | 1 |
| **303 | DSD-60206UK | WH CAN LED LINK | | 2 |
| **304 | DSD-60207UK | WH CAN LINK 1/2 | | 1 |
| **305 | DB-60030UK | WH LED WHT | | 1 |

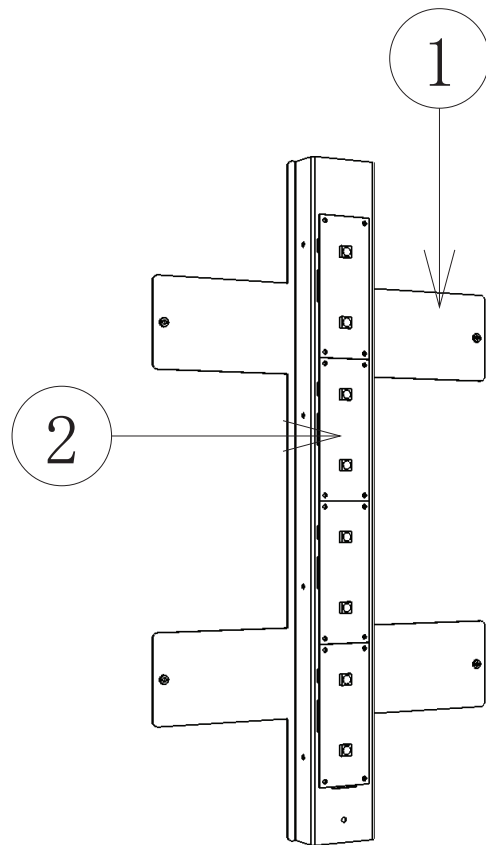

| ITEM NO | PART NO | DESCRIPTION | | QTY |
|---------|---------------|-----------------------------------|-----------|-----|
| **1 | DSD-5022XUK | MOUNT MARQUEE CAN LED | ALUMINIUM | 1 |
| **101 | 838-0028UK | LED RGB 8X3W CAN | | 1 |
| **201 | 000-P00308 | M3X8 MSCR PAN PAS | (101)-6 | 6 |
| **202 | 068-330808-PN | M3 WSHR 8OD FLT NYLON | (101)-6 | 6 |
| **203 | 280-A01013-PM | ROUTER TWIST D10 SO12.7 PANEL MNT | | 8 |

31 ASSY MARQUEE BLOCK CABI 1 (DSD-5025UK)

(D-1/1)

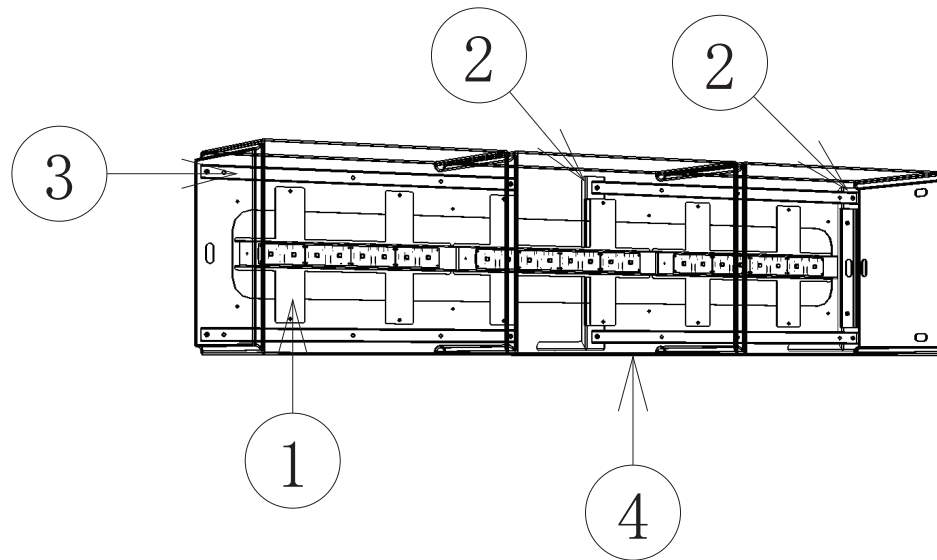

| ITEM NO | PART NO | DESCRIPTION | | QTY |
|---------|---------------|-------------------------|-------------|-----|
| **1 | DSD-5021UK | ASSY BLOCK LIGHTING | | 3 |
| **2 | DSD-5007UK | BRKT BLOCK LOCATING | up rev | 2 |
| **3 | DSD-5017UK | PLATE MARQUEE BLOCK NUT | up rev | 4 |
| **4 | DSD-6005UK | BLOCK MARQUEE | up rev | 1 |
| **201 | 008-B00416 | M4X16 TMP BH PAS | (1)-4 | 12 |
| **202 | 029-B00620-0B | M6X20 SKT BH BLK | (2)-2 | 4 |
| **203 | 050-F00600 | M6 NUT FLG SER PAS | (3)-2 | 8 |
| **204 | 060-S00400 | M4 WSHR SPR PAS | (1)-4 | 12 |
| **205 | 060-S00600 | M6 WSHR SPR PAS | (2)-2,(3)-2 | 12 |
| **206 | 068-441616 | M4 WSHR 16OD FLT PAS | (1)-4 | 12 |
| **207 | 068-652016 | M6 WSHR 20OD FLT PAS | (2)-2,(3)-2 | 12 |
| **301 | DSD-60209UK | WH AC BLOCK 2 | | 1 |
| **302 | DSD-60210UK | WH DC BLOCK 2 | | 1 |
| **303 | DSD-60206UK | WH CAN LED LINK | | 2 |
| **304 | DSD-60208UK | WH CAN LINK 2/1 | | 1 |
| **305 | DB-60030UK | WH LED WHT | | 1 |
| **306 | DSD-60211UK | WH CAN BLOCK LINK 1 | | 1 |

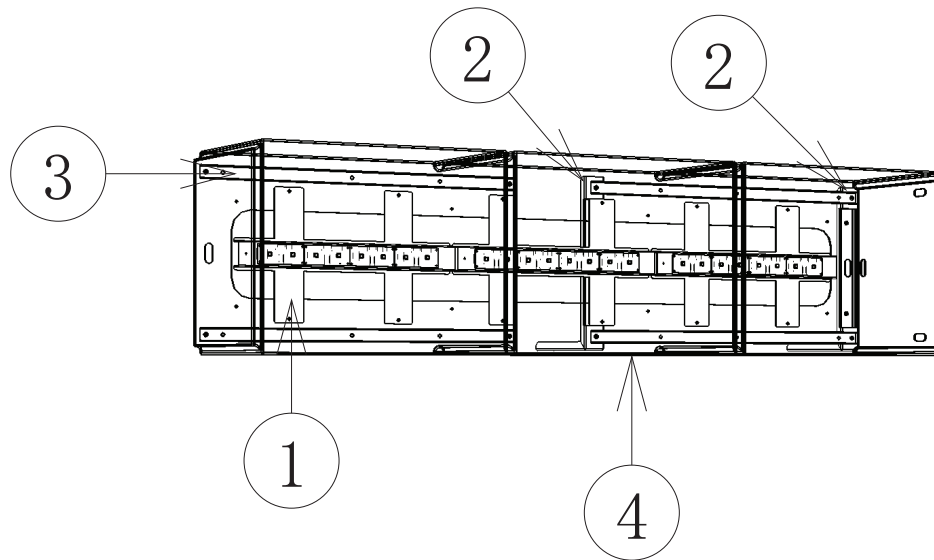

| ITEM NO | PART NO | DESCRIPTION | QTY |
|---------|---------------|-------------------------|-------------------|
| **1 | DSD-5021UK | ASSY BLOCK LIGHTING | 3 |
| **2 | DSD-5007UK | BRKT BLOCK LOCATING | up rev 2 |
| **3 | DSD-5017UK | PLATE MARQUEE BLOCK NUT | up rev 4 |
| **4 | DSD-6005UK | BLOCK MARQUEE | up rev 1 |
| **201 | 008-B00416 | M4X16 TMP BH PAS | (1)-4 12 |
| **202 | 029-B00620-OB | M6X20 SKT BH BLK | (2)-2 4 |
| **203 | 050-F00600 | M6 NUT FLG SER PAS | (3)-2 8 |
| **204 | 060-S00400 | M4 WSHR SPR PAS | (1)-4 12 |
| **205 | 060-S00600 | M6 WSHR SPR PAS | (2)-2,(3)-2 12 |
| **206 | 068-441616 | M4 WSHR 16OD FLT PAS | (1)-4 12 |
| **207 | 068-652016 | M6 WSHR 20OD FLT PAS | (2)-2,(3)-2 12 |
| **301 | DSD-60213UK | WH AC BLOCK 3 | 1 |
| **302 | DSD-60214UK | WH DC BLOCK 3 | 1 |
| **303 | DSD-60212UK | WH CAN BLOCK 2 | 1 |
| **304 | DSD-60206UK | WH CAN LED LINK | 2 |
| **305 | DB-60030UK | WH LED WHT | 1 |
| **306 | DSD-60215UK | WH CAN LINK 3/4 | 1 |

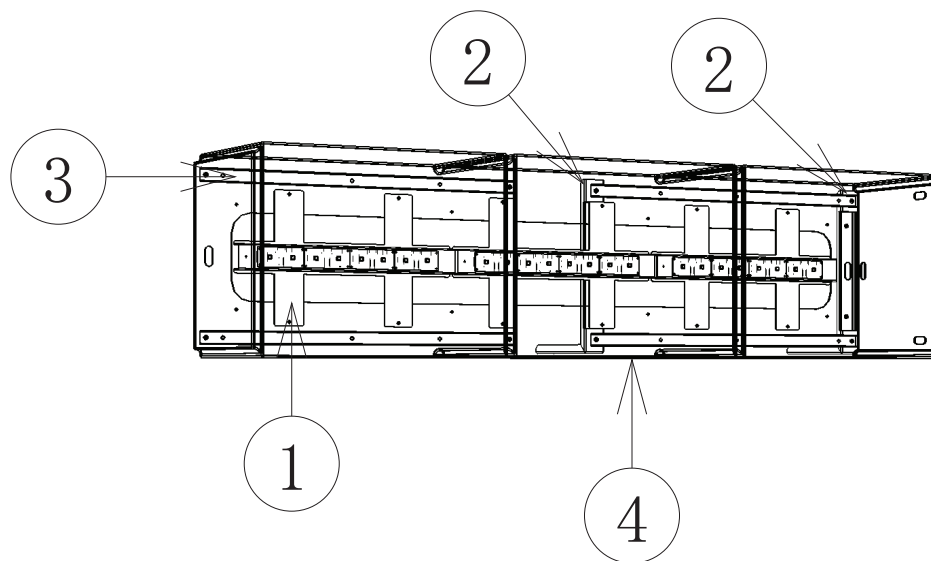

| ITEM NO | PART NO | DESCRIPTION | | QTY |
|---------|---------------|-------------------------|-------------|-----|
| **1 | DSD-5021UK | ASSY BLOCK LIGHTING | | 3 |
| **2 | DSD-5007UK | BRKT BLOCK LOCATING | up rev | 2 |
| **3 | DSD-5017UK | PLATE MARQUEE BLOCK NUT | up rev | 4 |
| **4 | DSD-6005UK | BLOCK MARQUEE | up rev | 1 |
| **201 | 008-B00416 | M4X16 TMP BH PAS | (1)-4 | 12 |
| **202 | 029-B00620-OB | M6X20 SKT BH BLK | (2)-2 | 4 |
| **203 | 050-F00600 | M6 NUT FLG SER PAS | (3)-2 | 8 |
| **204 | 060-S00400 | M4 WSHR SPR PAS | (1)-4 | 12 |
| **205 | 060-S00600 | M6 WSHR SPR PAS | (2)-2,(3)-2 | 12 |
| **206 | 068-441616 | M4 WSHR 16OD FLT PAS | (1)-4 | 12 |
| **207 | 068-652016 | M6 WSHR 20OD FLT PAS | (2)-2,(3)-2 | 12 |
| **301 | DSD-60216UK | WH AC BLOCK 4 | | 1 |
| **302 | DSD-60217UK | WH DC BLOCK 3 | | 1 |
| **303 | DSD-60218UK | WH CAN LINK 4/3 | | 1 |
| **304 | DSD-60206UK | WH CAN LED LINK | | 2 |
| **305 | DB-60030UK | WH LED WHT | | 1 |
| **306 | DSD-60211UK | WH CAN BLOCK LINK 1 | | 1 |

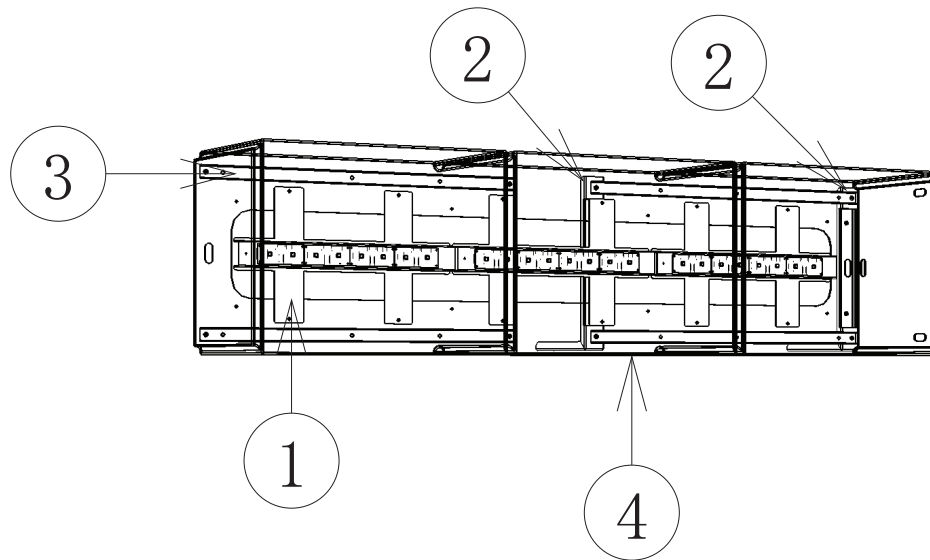

| ITEM NO | PART NO | DESCRIPTION | | QTY |
|---------|---------------|-------------------------|-------------|-----|
| **1 | DSD-5021UK | ASSY BLOCK LIGHTING | | 3 |
| **2 | DSD-5007UK | BRKT BLOCK LOCATING | up rev | 2 |
| **3 | DSD-5017UK | PLATE MARQUEE BLOCK NUT | up rev | 4 |
| **4 | DSD-6005UK | BLOCK MARQUEE | up rev | 1 |
| **201 | 008-B00416 | M4X16 TMP BH PAS | (1)-4 | 12 |
| **202 | 029-B00620-OB | M6X20 SKT BH BLK | (2)-2 | 4 |
| **203 | 050-F00600 | M6 NUT FLG SER PAS | (3)-2 | 8 |
| **204 | 060-S00400 | M4 WSHR SPR PAS | (1)-4 | 12 |
| **205 | 060-S00600 | M6 WSHR SPR PAS | (2)-2,(3)-2 | 12 |
| **206 | 068-441616 | M4 WSHR 16OD FLT PAS | (1)-4 | 12 |
| **207 | 068-652016 | M6 WSHR 20OD FLT PAS | (2)-2,(3)-2 | 12 |
| **301 | DSD-60223UK | WH AC BLOCK 5 | | 1 |
| **302 | DSD-60219UK | WH DC BLOCK 5 | | 1 |
| **303 | DSD-60212UK | WH CAN BLOCK 2 | | 1 |
| **304 | DSD-60206UK | WH CAN LED LINK | | 2 |
| **305 | DSD-60220UK | WH CAN LINK 5/6 | | 1 |
| **306 | DB-60030UK | WH LED WHT | | 1 |

35 ASSY BLOCK FAN (DSD-5040UK)

(D-1/1)

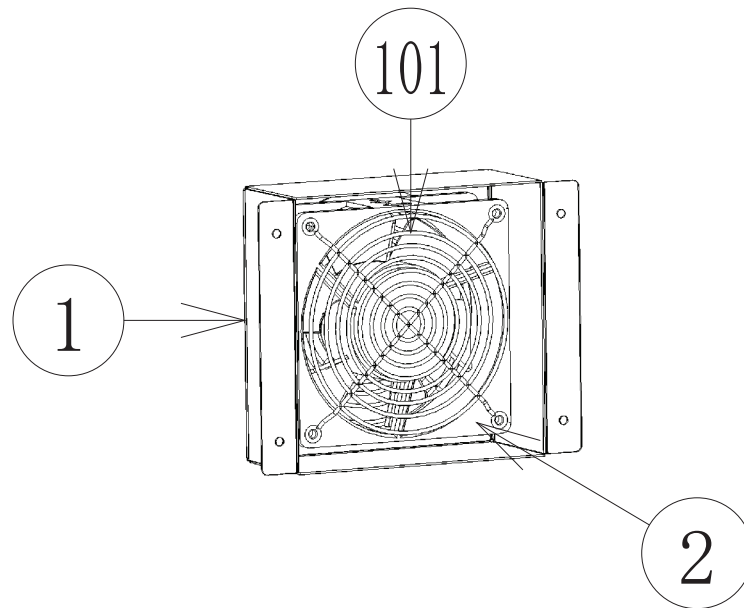

| ITEM NO | PART NO | DESCRIPTION | QTY |
|---------|---------------|-------------------------------|-------|
| **1 | DSD-5033UK | BRKT BLOCK FAN | 1 |
| **2 | 260-0012-01UK | FAN DC 12V ROHS | 1 |
| **101 | FN1012 | FAN GUARD METAL 120MM (FG 12) | 2 |
| **201 | 008-B00450 | M4X50 TMP BH PAS | (2)-4 |
| **202 | 050-F00400 | M4 NUT FLG SER PAS | (2)-4 |

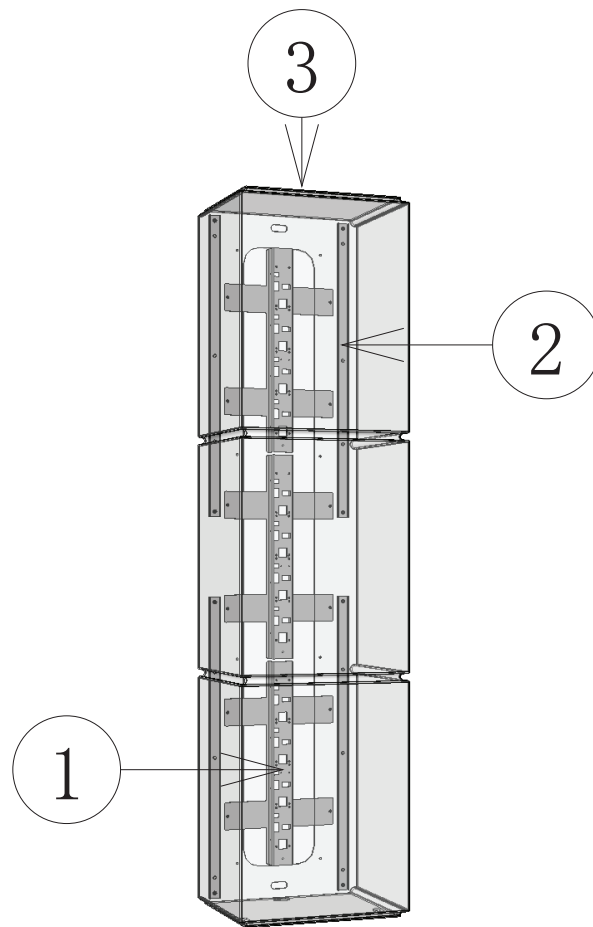

| ITEM NO | PART NO | DESCRIPTION | | QTY |
|---------|---------------|-------------------------|-------|-----|
| **1 | DSD-5021UK | ASSY BLOCK LIGHTING | | 3 |
| **2 | DSD-5017UK | PLATE MARQUEE BLOCK NUT | | 4 |
| **3 | DSD-6005UK | BLOCK MARQUEE | | 1 |
| **201 | 008-B00416 | M4X16 TMP BH PAS | (1)-4 | 12 |
| **202 | 029-B00620-0B | M6X20 SKT BH BLK | (2)-2 | 8 |
| **203 | 050-F00600 | M6 NUT FLG SER PAS | (2)-1 | 4 |
| **204 | 060-S00400 | M4 WSHR SPR PAS | (1)-4 | 12 |
| **205 | 060-S00600 | M6 WSHR SPR PAS | (2)-3 | 12 |
| **206 | 068-441616 | M4 WSHR 16OD FLT PAS | (1)-4 | 12 |
| **207 | 068-652016 | M6 WSHR 20OD FLT PAS | (2)-3 | 12 |

37 ASSY 42" LED DISPLAY (DSD-5100UK)

(D-1/2)

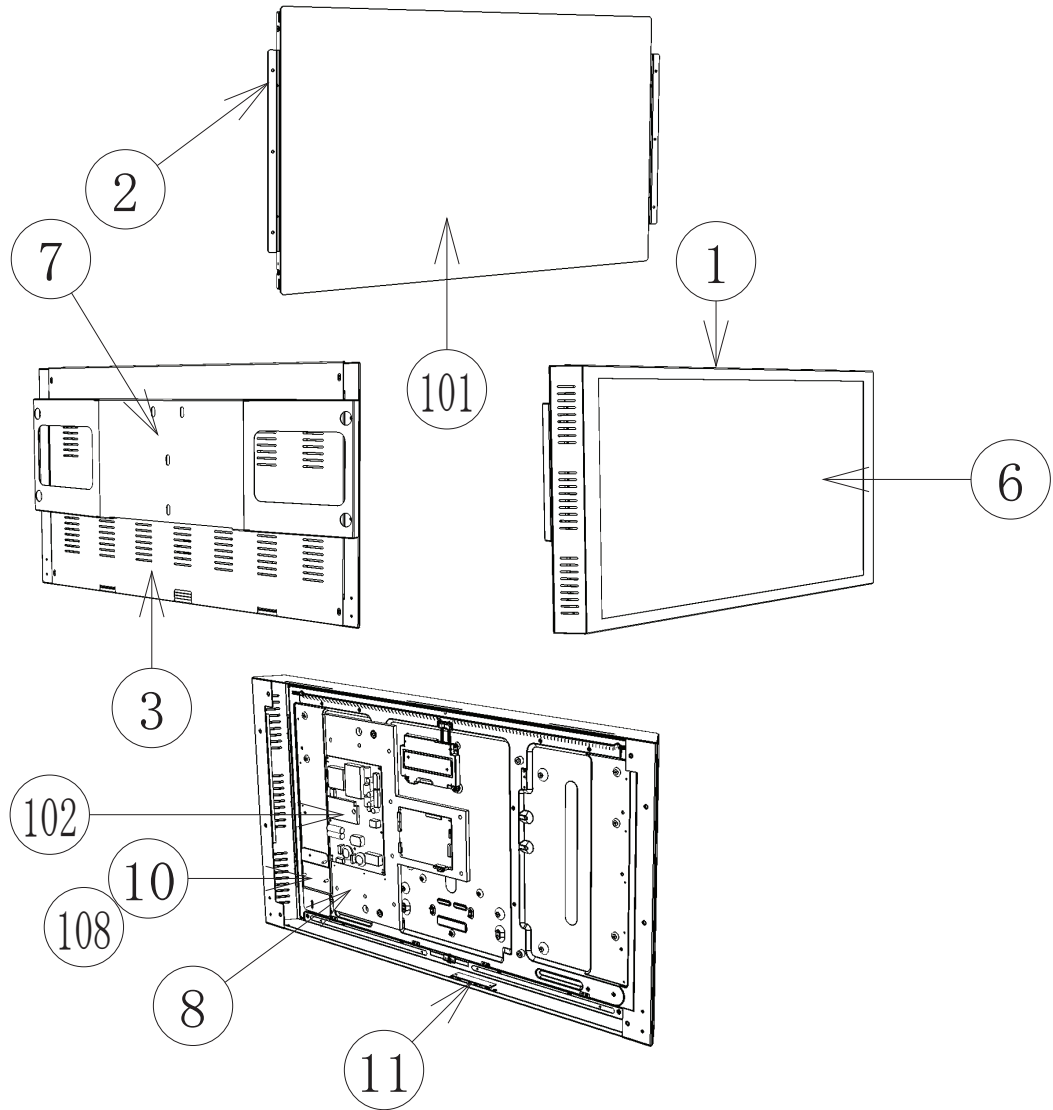

| ITEM NO | PART NO | DESCRIPTION | QTY |
|---------|-----------------|---------------------------------|-----|
| **1 | DSD-5101UK | ENCLOSURE 42 LED | 1 |
| **2 | DSD-5102UK | BRKT LED MOUNT | 2 |
| **3 | DSD-5103UK | COVER BACK | 1 |
| **4 | | | |
| **5 | | | |
| **6 | DSD-5106UK | PERSPEX LED SCREEN PROTECT | 1 |
| **7 | DSD-5107UK | BRKT LED ASSY LOCATING | 1 |
| **8 | DSD-5108UK | PNL PRISMA BD DMODUL MOUNT | 1 |
| **10 | DSD-5109UK | BRKT LED FILTER | 1 |
| **11 | DSD-5111UK | PLATE OSD COVER | 1 |
| **101 | 200-6042-02-AUO | DISPLAY 42" LED AUO P420HVN02.0 | 1 |
| **102 | 400-160-15224 | PSU 42" LED DPS-160AP-2A-PD01 | 1 |
| **103 | 440-DS0010UK | STICKER DANGER HIGH VOLTAGE | 1 |
| **104 | 280-A01264-WX | ROUTER TWIST D12 SO6.4 WOOD X | 12 |

| | | | | |
|-------|---------------|-----------------------------|--------------------|------|
| **105 | OS1230 | FOAM STRIP 2MM X 10MM | | 2.3m |
| **106 | 280-L00709-OS | STANDOFF 7OD 4ID 9L | (102)-4,(PRISMA)-4 | 8 |
| **107 | | | | |
| **108 | EP1419 | FILTER SCHAFFNER 2030-16-06 | | 1 |
| **201 | 000-P00308 | M3X8 MSCR PAN PAS | (OSD)-2,(2)-2 | 6 |
| **202 | 000-P00408 | M4X8 MSCR PAN PAS | (10)-2 | 2 |
| **203 | 012-P00320 | N4X3/4" S/TAP PAN PAS | (102)-4,(PRISMA)-4 | 8 |
| **204 | 029-B00620-0Z | M6X20 SKT BH 0Z | (3)-4,(7)-4,(8)-2 | 10 |
| **205 | 050-F00400 | M4 NUT FLG SER PAS | (101)-6 | 6 |
| **206 | | | | |
| **207 | 060-S00400 | M4 WSHR SPR PAS | (101)-6 | 6 |
| **208 | 060-S00600 | M6 WSHR SPR PAS | (3)-4,(7)-4,(8)-2 | 10 |
| **209 | 068-330808-PN | M3 WSHR 8OD FLT NYLON | (OSD)-2 | 2 |
| **210 | 068-441616 | M4 WSHR 16OD FLT PAS | (101)-6 | 6 |
| **211 | 068-652016 | M6 WSHR 20OD FLT PAS | (3)-4,(7)-4,(8)-2 | 10 |
| **212 | 029-B00412-0B | M4X12 SKT BH BLK | (11)-2 | 2 |
| **301 | EP1460 | IEC MALE - FEMALE EXTN 5M | | 1 |
| **302 | TRF-60028UK | WH IEC DISPLAY | | 1 |

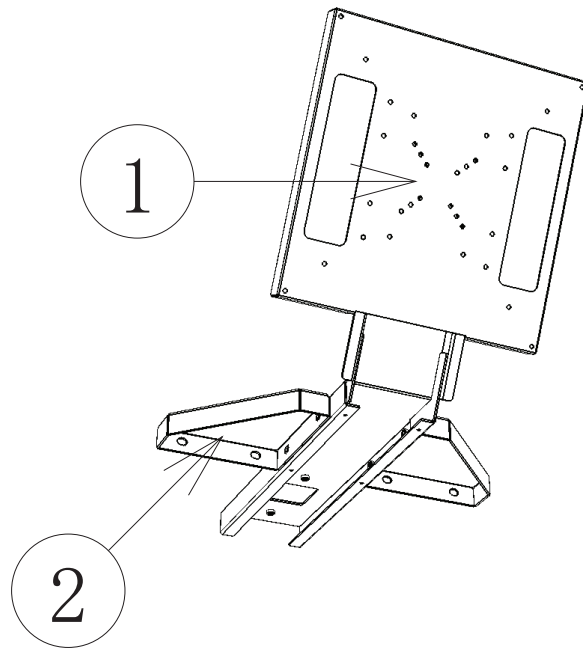

| ITEM NO | PART NO | DESCRIPTION | QTY |
|---------|---------------|-----------------------|---------|
| **1 | DSD-5121UK | MOUNT LED ASSY CABI | 1 |
| **2 | DSD-5122UK | BRKT LED ASSY SUPPORT | 2 |
| **201 | 020-000820-OZ | M8X20 SKT CAP OZ | (2)-2 4 |
| **202 | 060-S00800-0B | M8 WSHR SPR BLK | (2)-2 4 |
| **203 | 068-852216-0B | M8 WSHR 22OD FLT BLK | (2)-2 4 |

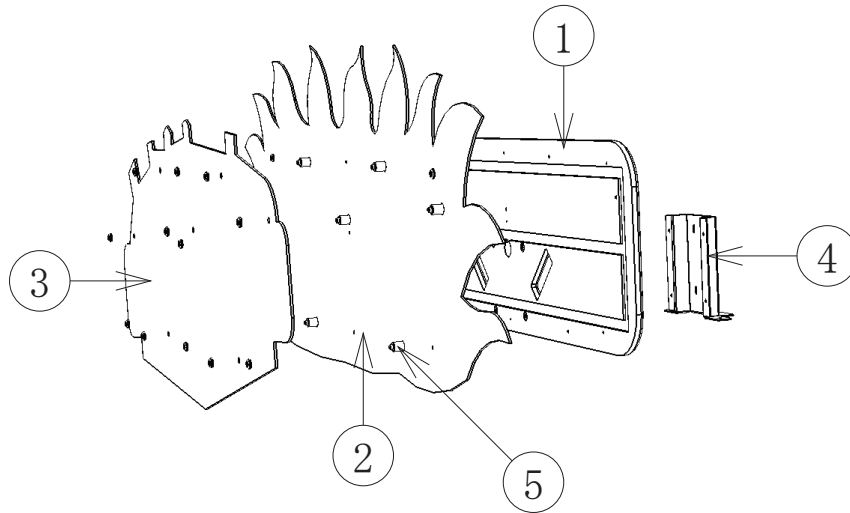

ITEM NO PART NO DESCRIPTION QTY

| | | | | |
|-------|---------------|---------------------------|-------|---|
| **1 | DSD-5201UK | PANEL BILLBOARD | | 1 |
| **2 | DSD-5202UK | BILLBOARD INNER ACRYLIC | | 1 |
| **3 | DSD-5203UK | BILLBOARD OUTER ACRYLIC | | 1 |
| **4 | DSD-5205UK | BRKT BILLBOARD LOCATING | | 1 |
| **5 | DB-0504UK | SPACER STANDOFF LONG | | 7 |
| **201 | 020-000510-0C | M5X10 SKT CAP BZP | (3)-7 | 7 |
| **202 | 029-B00625 | M6X25 SKT BH BLK | (4)-2 | 4 |
| **203 | 060-S00500 | M5 WSHR SPR PAS | (5)-1 | 7 |
| **204 | 060-S00600 | M6 WSHR SPR PAS | (4)-2 | 4 |
| **205 | 068-552016 | M5 WSHR 20OD FLT PAS | (5)-1 | 7 |
| **206 | 068-652016 | M6 WSHR 20OD FLT PAS | (4)-2 | 4 |
| **207 | 080-B00450 | M4X50 TMP PRF BH PAS | (2)-7 | 7 |
| **208 | 080-B00530 | M5X30 TMP PRF BH PAS | (5)-1 | 7 |
| **209 | 280-6686-01UK | 4.5X16X4 SP WSHR | (2)-7 | 7 |
| **210 | 280-6696UK | 5.5X20X6.3 WSHR SPCL AL | (3)-7 | 7 |
| **211 | 280-L01030-OS | STANDOFF 10OD 5.2ID 30L | (2)-7 | 7 |
| **301 | | | | |
| **302 | | | | |
| **303 | DSD-6006UK | ASSY BILLBOARD LED 1200MM | | 1 |

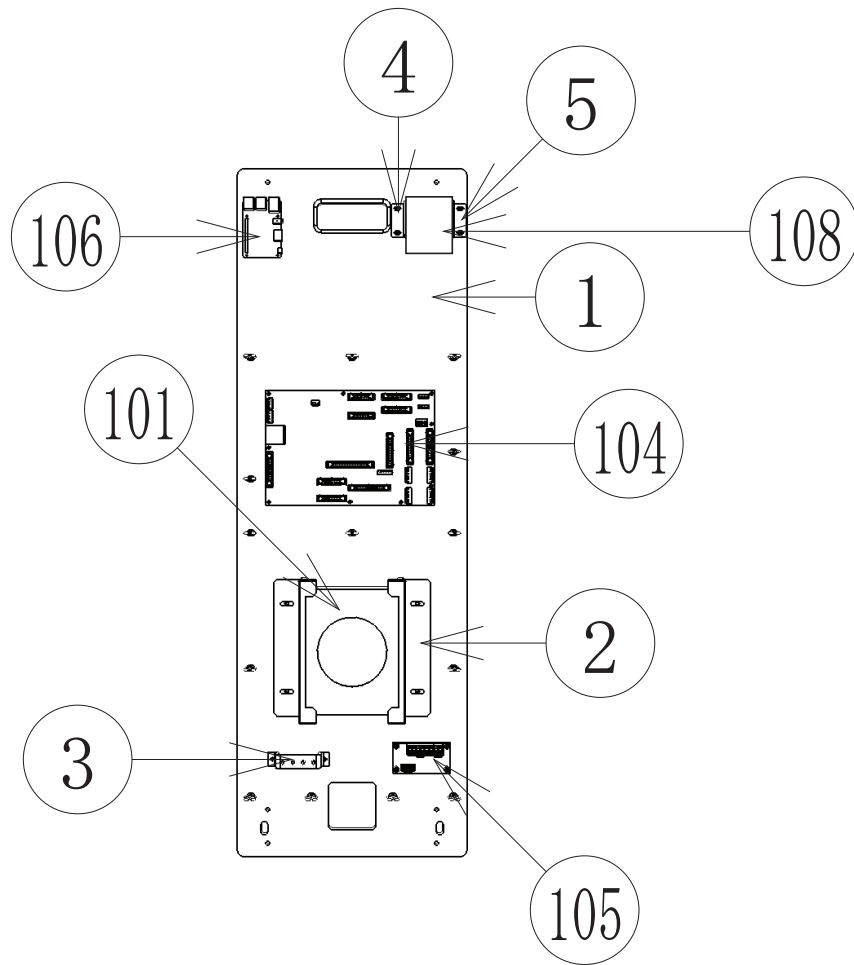

| ITEM NO | PART NO | DESCRIPTION | QTY |
|---------|-----------------|-------------------------------|-------------------|
| **1 | DSD-5401UK | BOARD MARQUEE ELEC | 1 |
| **2 | DSD-5402UK | BRKT PSU MOUNT | 2 |
| **3 | CFB-4003-01UK | EARTH PLATE | 1 |
| **4 | DSD-5403UK | BRKT VIDEO SW LH | 2 |
| **5 | DSD-5404UK | BRKT VIDEO SW RH | 2 |
| **101 | 400-1000-ATX-01 | ATX 1KW CORSAIR CP-9020062-UK | 1 |
| **102 | 280-L00640-WX | STANDOFF 6MM WOOD XL | (101)-9 |
| **103 | 280-A01264-WX | ROUTER TWIST D12 SO6.4 WOOD X | 12 |
| **104 | 838-0023UK | PCBA - RED ONE | 1 |
| **105 | 838-14551-02UK | AC DISTRIBUTION BD | 1 |
| **106 | 610-1002-01UK | RASPBERRY Pi B+ 811-1284 | 1 |
| **107 | | | |
| **108 | EP1454 | VIDEO SPLITTER HDMI-HDMI | 1 |
| **109 | 600-7012-100UK | HDMI-HDMI CABLE 100cm | 1 |
| **201 | 012-P03512-F | N6X1/2" S/TAP FLG PAS | (3)-2,(4)-2,(5)-2 |
| **202 | 008-B00416 | M4X16 TMP BH PAS | (2)-2,(4)-2,(5)-2 |
| **203 | 060-S00400 | M4 WSHR SPR PAS | (2)-2,(4)-2,(5)-2 |
| **204 | 068-441616 | M4 WSHR 16OD FLT PAS | (2)-2,(4)-2,(5)-2 |
| **205 | 012-P00325 | N4X1" S/TAP PAN PAS | (105)-4, |
| **301 | DSD-60201UK | WH AC DIST | 1 |
| **302 | DSD-60202UK | WH DC RED ONE | 1 |
| **303 | DSD-60203UK | WH RED ONE CAN | 1 |
| **304 | DSD-60226UK | WH EXTENSION LEAD | 1 |
| **305 | | | |
| **306 | DSD-60231UK | WH Pi POWER / CAMERA | 1 |

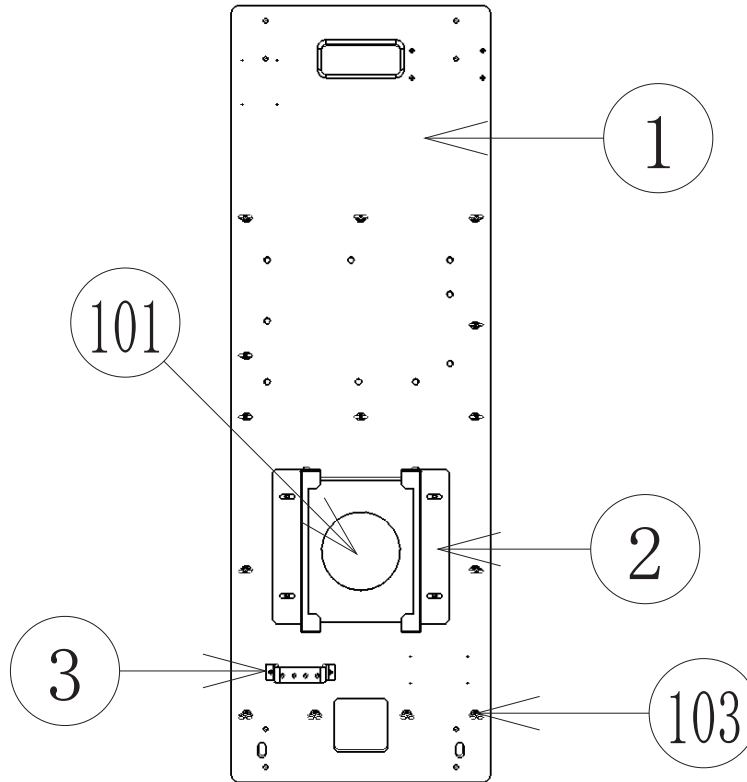

ITEM NO PART NO DESCRIPTION QTY

| | | | | |
|-------|-----------------|-------------------------------|---------|----|
| **1 | DSD-5401UK | BOARD MARQUEE ELEC | | 1 |
| **2 | DSD-5402UK | BRKT PSU MOUNT | | 2 |
| **3 | CFB-4003-01UK | EARTH PLATE | | 1 |
| **101 | 400-1000-ATX-01 | ATX 1KW CORSAIR CP-9020062-UK | | 1 |
| **102 | 280-L00640-WX | STANDOFF 6MM WOOD XL | (101)-9 | 9 |
| **103 | 280-A01264-WX | ROUTER TWIST D12 SO6.4 WOOD X | | 12 |
| **201 | 012-P03512-F | N6X1/2" S/TAP FLG PAS | (3)-2 | 2 |
| **202 | 008-B00416 | M4X16 TMP BH PAS | (2)-2 | 4 |
| **203 | 060-S00400 | M4 WSHR SPR PAS | (2)-2 | 4 |
| **204 | 068-441616 | M4 WSHR 16OD FLT PAS | (2)-2 | 4 |

④① ASSY MARQUEE VIDEO ELEC BD (DSD-5420UK)

(D-1/1)

| ITEM NO | PART NO | DESCRIPTION | QTY |
|---------|---------------|-------------------------------|-----|
| *1 | DSD-5421UK | BOARD MARQUEE VIDEO ELEC | 1 |
| *101 | 280-A01264-WX | ROUTER TWIST D12 SO6.4 WOOD X | 12 |
| *102 | | RASPBERRY PI | 1 |
| *103 | | PSU PI | 1 |
| *104 | | VIDEO SWITCH HDMI TO DVI | 4 |
| *105 | | USB A-A EXTENSION | 1 |
| *106 | | HDMI-HDMI CABLE | 1 |
| *107 | | HDMI-DVI CABLE | 2 |
| *108 | | VIDEO SW PSU | 1 |
| *109 | | 2 GANG 13A UK SOCKET | 1 |
| *110 | | | |
| *111 | | | |
| ***301 | DSD-6XXXXUK | | 1 |

④① ASSY AC SWITCH (DSD-5700UK)

(D-1/1)

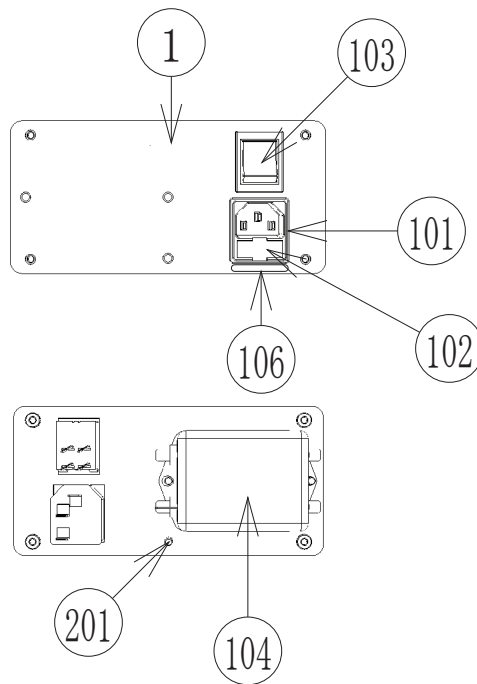

| | | | | |
|-------|---------------|------------------------------|------------------|---|
| **1 | DSD-5701UK | PLATE MAINS IN | | 1 |
| **101 | EP1302 | EUROSOCKET FUSED 10A 250VAC | | 1 |
| **102 | 514-5078-5000 | FUSE 5X20 CERAMIC SB 500mA | | 2 |
| **103 | SW1109 | SWITCH ROCKER 250V AC | | 1 |
| **104 | EP1419 | FILTER SCHAFFNER 2030-16-06 | | 1 |
| **105 | 310-5029-D508 | HEAT SHRINK SLEEVING 50.8DIA | (101)-4 | 4 |
| **106 | LB1126-5-250 | FUSE LABEL 5A 250V | | 1 |
| **201 | 050-F00400 | M4 NUT FLG SER PAS | (104)-2, 2-EARTH | 4 |
| **301 | DSD-60200UK | WH AC IN | | 1 |
| **302 | 600-9040-44K | WH EARTH 400MM M4M4 | | 1 |

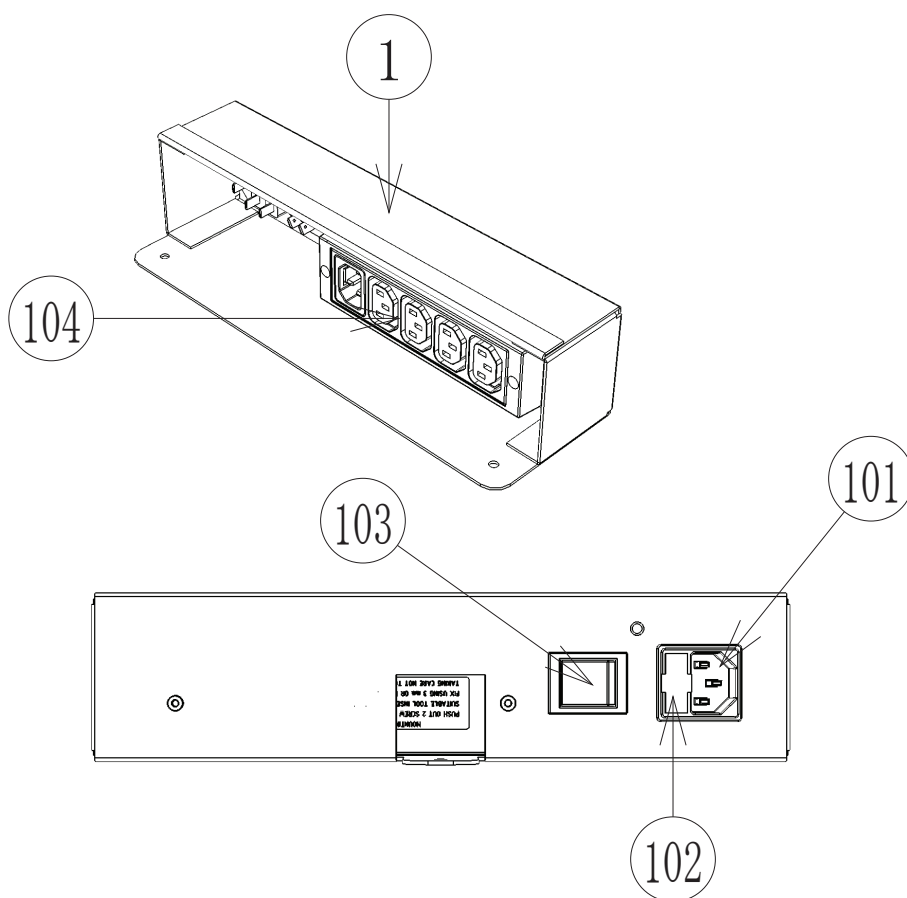

| ITEM NO | PART NO | DESCRIPTION | | QTY |
|---------|---------------|------------------------------|---------|-----|
| **1 | DSD-5751UK | BRKT INLET OUTLET SW | | 1 |
| **101 | EP1302 | EUROSOCKET FUSED 10A 250VAC | PUSH IN | 1 |
| **102 | 514-5078-5000 | FUSE 5X20 CERAMIC SB 500mA | | 1 |
| **103 | SW1109 | SWITCH ROCKER 250V AC | PUSH IN | 1 |
| **104 | EP1458 | IEC x4 POWER BLOCK 261-5014 | | 1 |
| **105 | EP1459 | 1M IEC C14 PLUG TO UK SOCKET | | 1 |
| **201 | 000-P00308 | M3X8 MSCR PAN PAS | (104)-2 | 2 |
| **202 | 060-F00300 | M3 WSHR FORM A FLT PAS | (104)-2 | 2 |
| **203 | 050-F00400 | M4 NUT FLG SER PAS | 1-EARTH | 1 |
| **301 | DSD-60230UK | WH POWER BLOCK | | 1 |

19 WIRE COLOUR CODE TABLE

⚠ WARNING

The DC power wire color for this product is different from previous SEGA titles. Working from the previous wire colors will create a high risk of fire.

The color codes for the wires used in the diagrams in the following chapter are as follows.

| | |
|---|-------------|
| A | PINK |
| B | SKY BLUE |
| C | BROWN |
| D | PURPLE |
| E | LIGHT GREEN |

Wires other than those of any of the above 5 single colors will be displayed by 2 alphanumeric characters.

| | |
|---|--------|
| 1 | RED |
| 2 | BLUE |
| 3 | YELLOW |
| 4 | GREEN |
| 5 | WHITE |
| 7 | ORANGE |
| 8 | BLACK |
| 9 | GRAY |

If the right-hand side numeral of the code is 0, then the wire will be of a single color shown by the left-hand side numeral (see the above).

Note 1: If the right-hand side numeral is not 0, that particular wire has a spiral color code. The left-hand side character shows the base color and the right-hand side one, the spiral color.

<Example> 51.....WHITE/RED



Note 2: The character following the wire color code indicates the size of the wire.

| | |
|-------|-------|
| U: | AWG16 |
| K: | AWG18 |
| L: | AWG20 |
| None: | AWG22 |

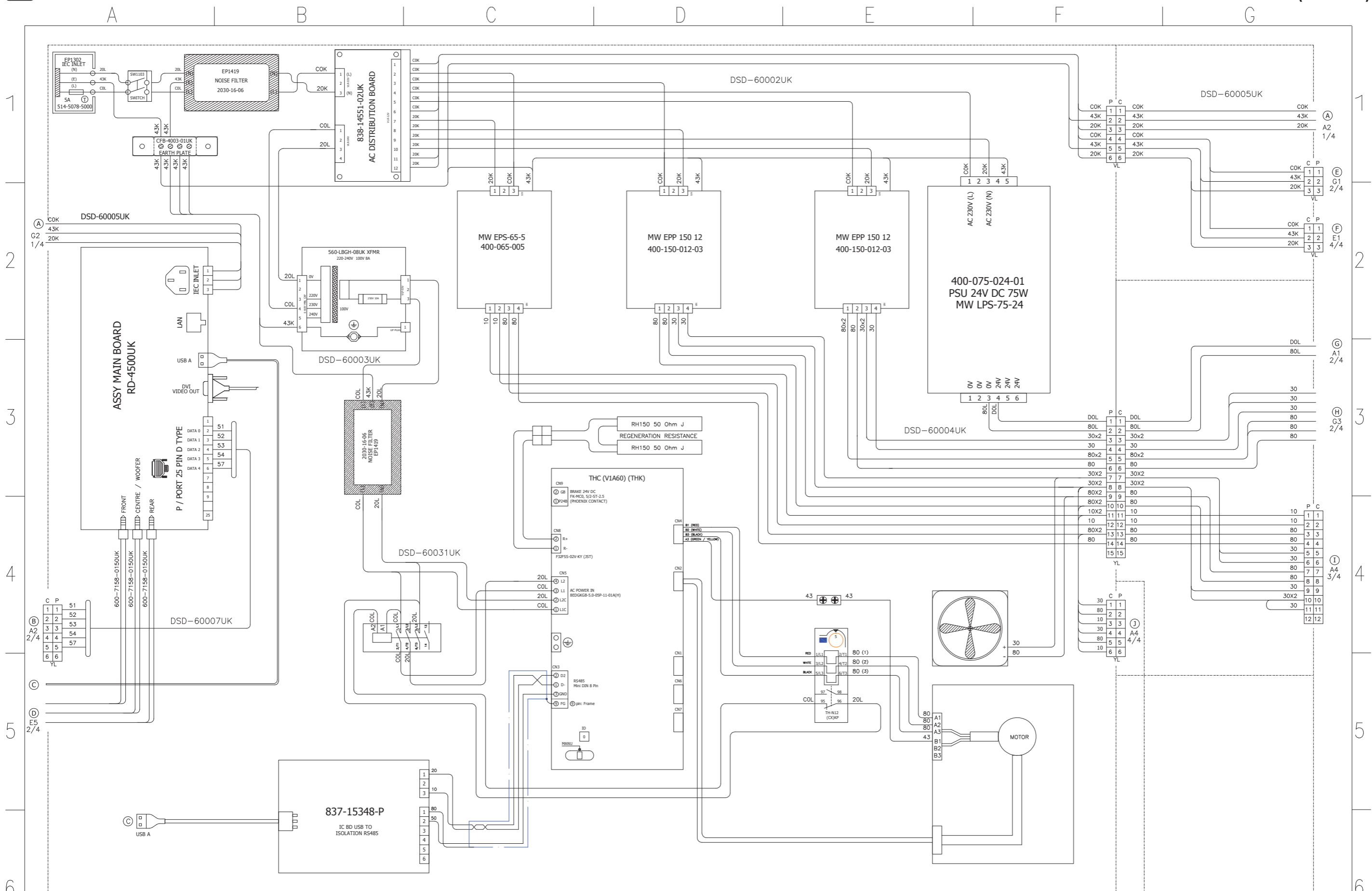

| | | | | | | | | | |
|------------|--------|-------------|--------------|-------|--|----------------------------|--|------------------------------------------------------------------|--|
| ALTERATION | | PART NUMBER | | DRAWN | | DESCRIPTION | | ORIGINAL SIZE | |
| 8 | BLACK | 4.3 | EARTH WIRE | RA | | SEGA AMUSEMENTS EUROPE LTD | | A2 1 OF 4 | |
| 7 | ORANGE | ? | AWG18 UL1672 | | | SHOWDOWN SUPERDELUXE | | THIS DRAWING WILL IN NO WAY BE COPIED, TO BE RETURNED ON DEMAND. | |
| 6 | WHITE | E | LIGHT GREEN | | | | | | |
| 5 | GREEN | D | PURPLE | | | | | | |
| 4 | BROWN | C | BROWN | | | | | | |
| 3 | YELLOW | B | SKY BLUE | | | | | | |
| 2 | BLUE | A | PINK | | | | | | |
| 1 | RED | 9 | GRAY | | | | | | |

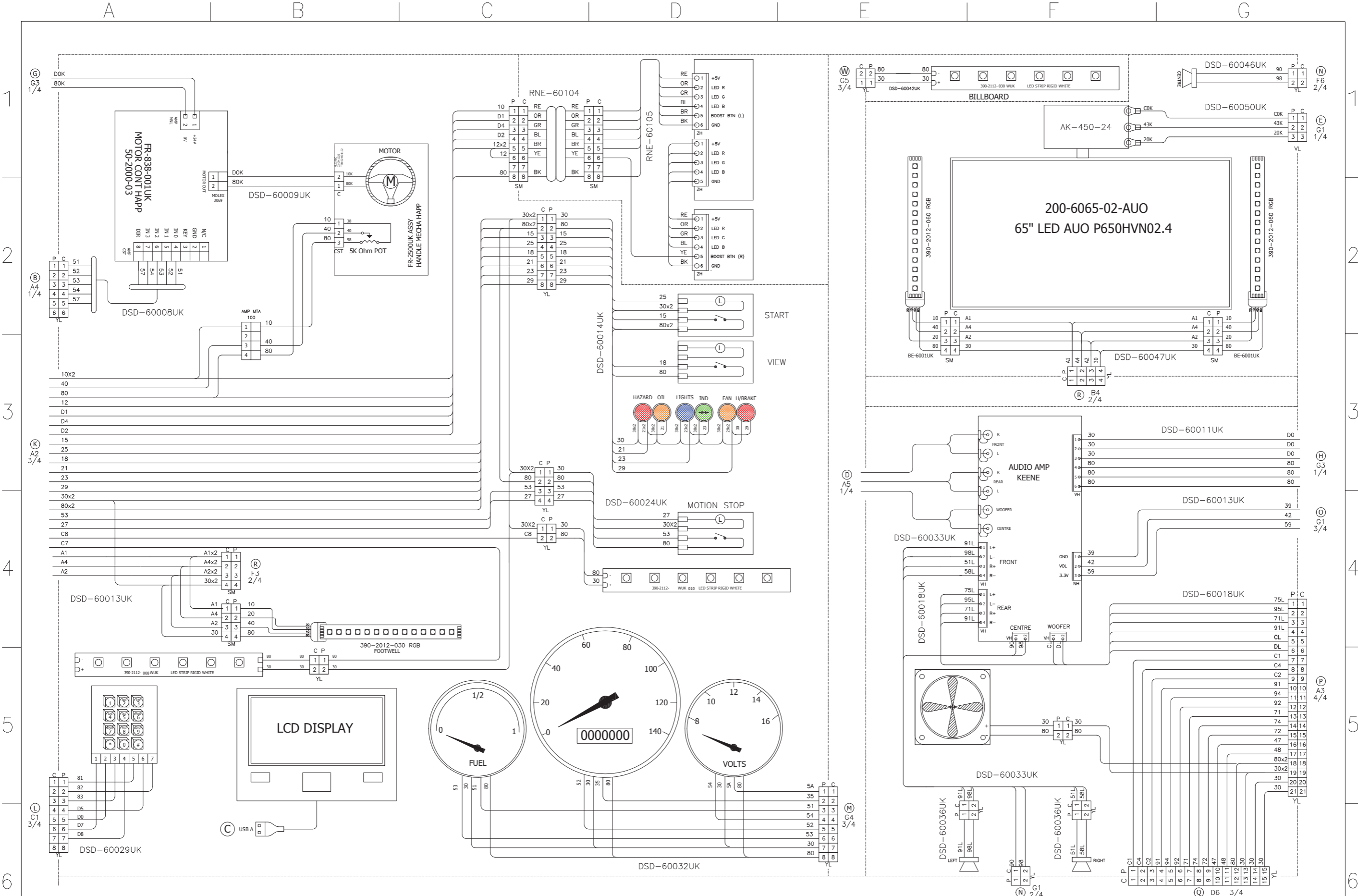

| | | | | | |
|---|--------|---|-------------|-----|--------------|
| 8 | BLACK | E | LIGHT GREEN | 4-3 | EARTH WIRE |
| 7 | ORANGE | E | LIGHT GREEN | ? | AWG18 UL1672 |
| 5 | WHITE | D | PURPLE | ? | AWG20 UL1672 |
| 4 | GREEN | C | BROWN | U | AWG16 UL1015 |
| 3 | YELLOW | B | SKY BLUE | K | AWG18 UL1015 |
| 2 | BLUE | A | PINK | L | AWG20 UL1007 |
| 1 | RED | 9 | GRAY | T | AWG22 UL1007 |
| | | | | | AWG24 UL1007 |

| | |
|-------------|--|
| DRAWN | |
| RA | |
| PART NUMBER | |

SEGA AMUSEMENTS EUROPE LTD
SHOWDOWN SUPERDELUXE

ORIGINAL SIZE
 A2 2 OF 4

THIS DRAWING WILL IN NO WAY BE COPIED.
 TO BE RETURNED ON DEMAND.

ALTERATION

DESCRIPTION

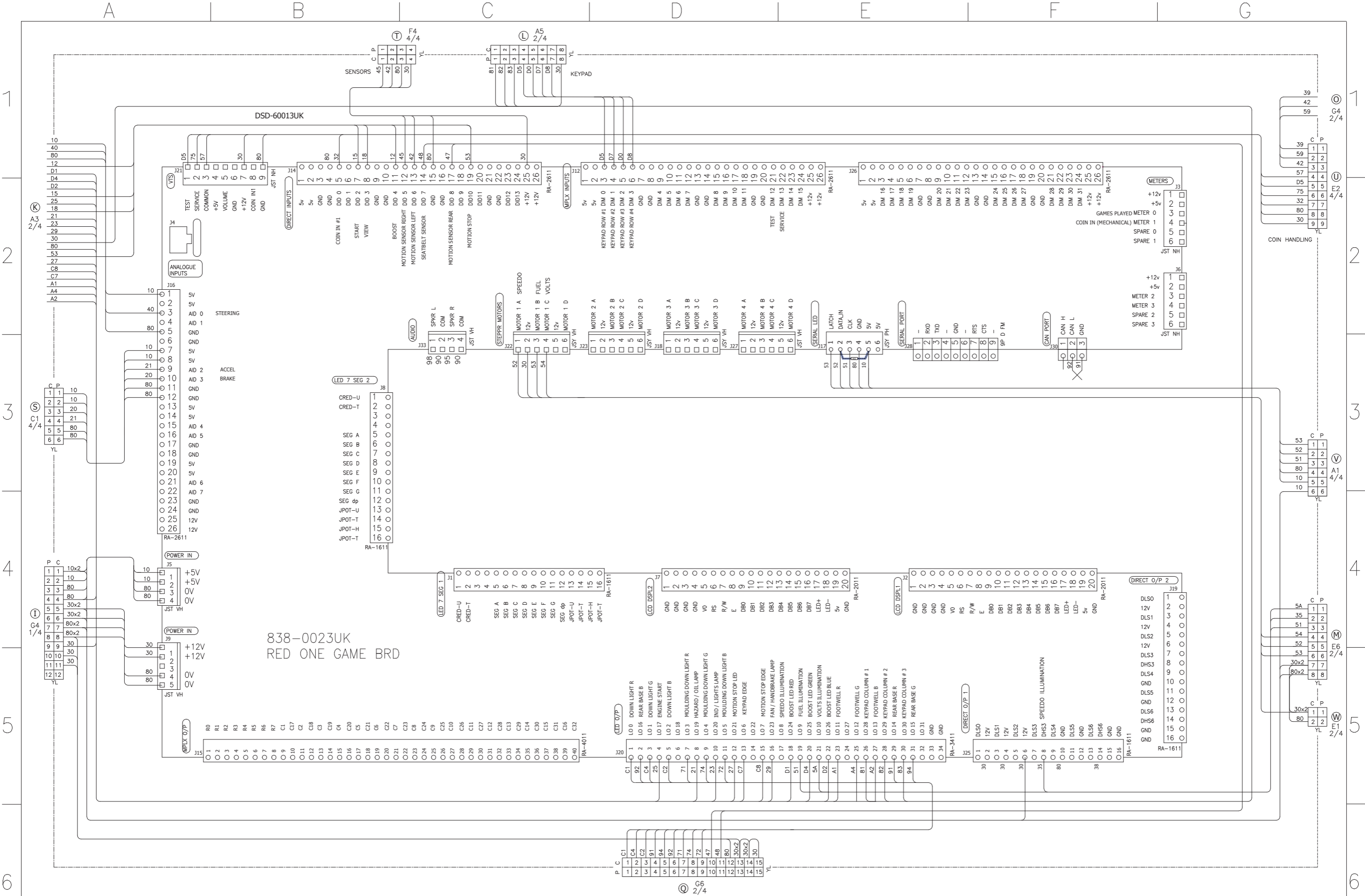

838-0023UK
RED ONE GAME BRD

| | | | | | |
|---|--------|---|-------------|-----|--------------|
| 8 | BLACK | E | LIGHT GREEN | 4.3 | EARTH WIRE |
| 7 | ORANGE | F | PURPLE | ? | AWG18 UL1672 |
| 5 | WHITE | D | BROWN | ? | AWG20 UL1672 |
| 4 | GREEN | C | SKY BLUE | U | AWG16 UL1015 |
| 3 | YELLOW | B | PINK | K | AWG18 UL1015 |
| 2 | BLUE | A | GRAY | L | AWG20 UL1007 |
| 1 | RED | 9 | | T | AWG22 UL1007 |
| | | | | | AWG24 UL1007 |

PART NUMBER

DRAWN

SEGA AMUSEMENTS EUROPE LTD

THIS DRAWING WILL IN NO WAY BE COPIED, TO BE RETURNED ON DEMAND.

SHOWDOWN SUPERDELUXE

ORIGINAL SIZE
A2 3.0F4

ALTERATION

DESCRIPTION

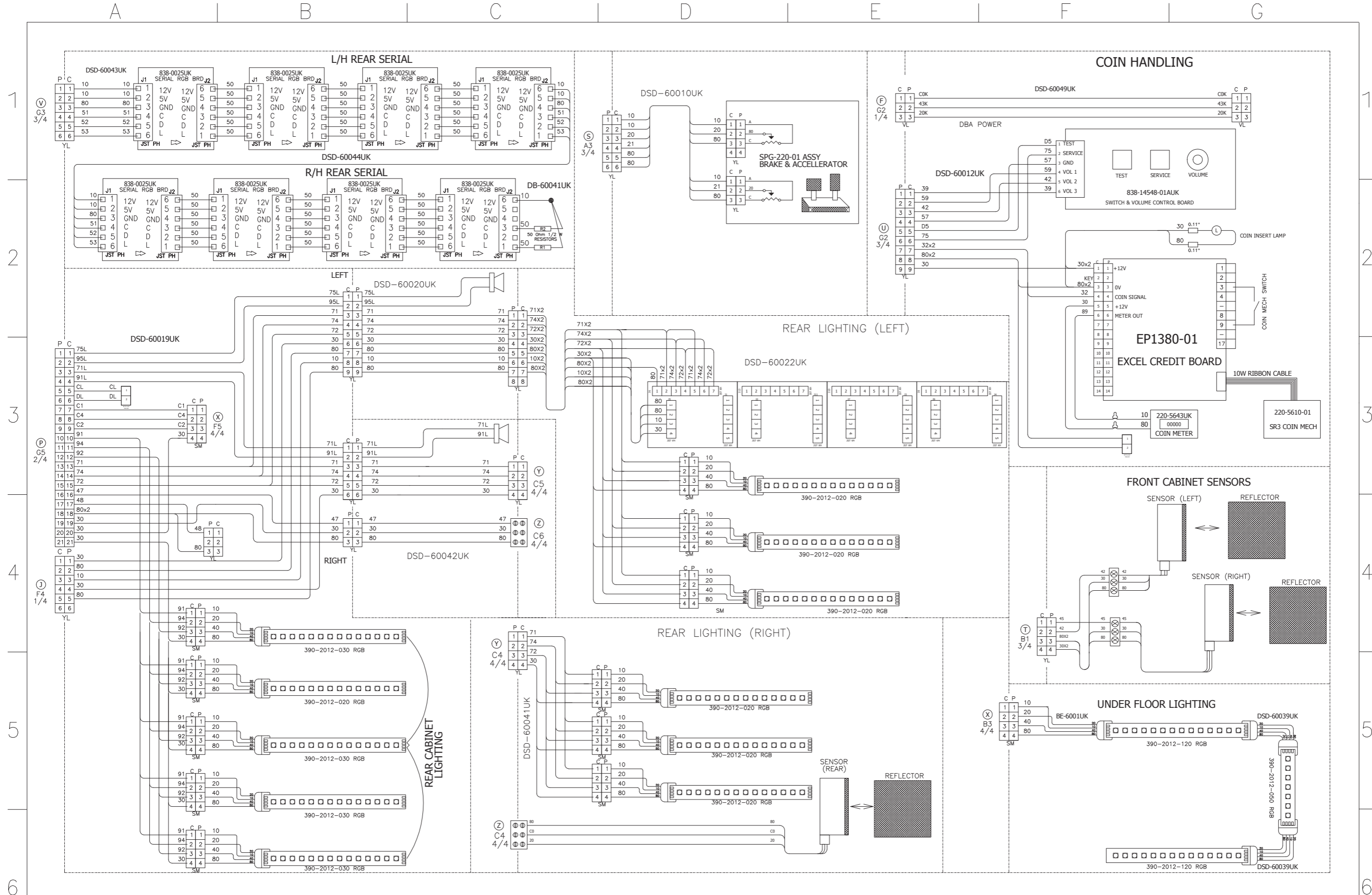

| | | | | | |
|---|--------|---|-------------|--------------|--------------|
| 8 | BLACK | E | LIGHT GREEN | 4.3 | EARTH WIRE |
| 7 | ORANGE | D | PURPLE | ? | AWG18 UL1672 |
| 6 | WHITE | C | BROWN | ? | AWG20 UL1672 |
| 5 | GREEN | B | SKY BLUE | U | AWG16 UL1015 |
| 4 | YELLOW | A | PINK | K | AWG18 UL1015 |
| 3 | BLUE | 9 | GRAY | L | AWG20 UL1007 |
| 2 | RED | T | | AWG22 UL1007 | |
| 1 | | | | AWG24 UL1007 | |

DRAWN
RA

SEGA AMUSEMENTS EUROPE LTD
SHOWDOWN SUPERDELUXE
THIS DRAWING WILL IN NO WAY BE COPIED.
TO BE RETURNED ON DEMAND.
ORIGINAL SIZE
A2 4 OF 4

| | | |
|------------|-------------|-------------|
| ALTERATION | PART NUMBER | DESCRIPTION |
| A | B | C |
| D | E | F |
| G | | |

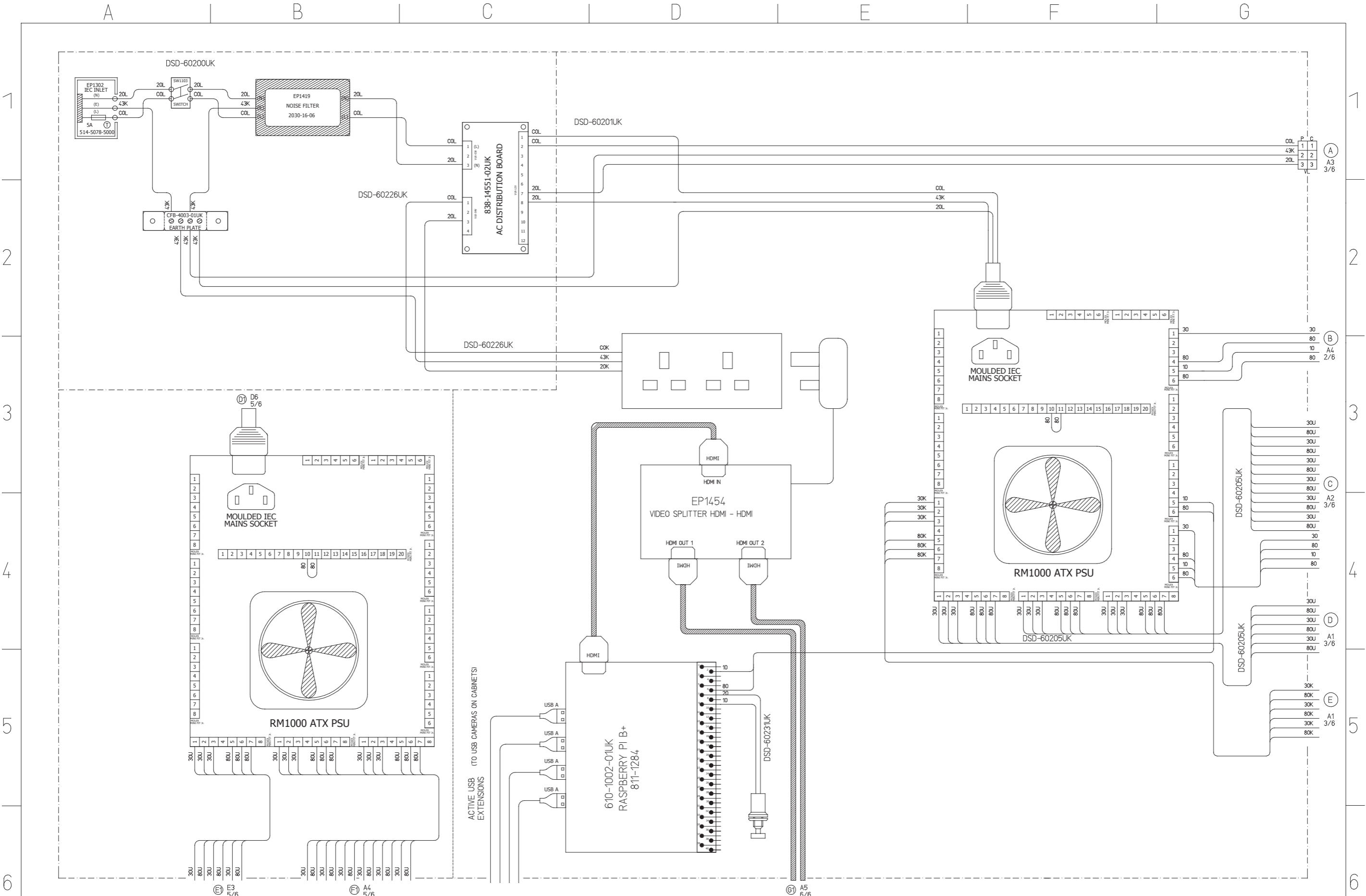

| | | | | | |
|---|--------|---|-------------|----|--------------|
| 8 | BLACK | E | LIGHT GREEN | 43 | EARTH WIRE |
| 7 | ORANGE | D | PURPLE | 7 | AWG18 UL1672 |
| 5 | WHITE | C | BROWN | 7 | AWG20 UL1672 |
| 4 | GREEN | B | SKY BLUE | U | AWG16 UL1015 |
| 3 | YELLOW | A | PINK | K | AWG18 UL1015 |
| 2 | BLUE | A | PINK | L | AWG20 UL1007 |
| 1 | RED | 9 | GRAY | L | AWG22 UL1007 |
| | | | | T | AWG24 UL1007 |

PART NUMBER

DRAWN
RA

SEGA AMUSEMENTS EUROPE LTD
SHOWDOWN SDX GANTRY

THIS DRAWING WILL IN NO WAY BE COPIED.
TO BE RETURNED ON DEMAND.

ORIGINAL SIZE
A2

ALTERATION

DESCRIPTION

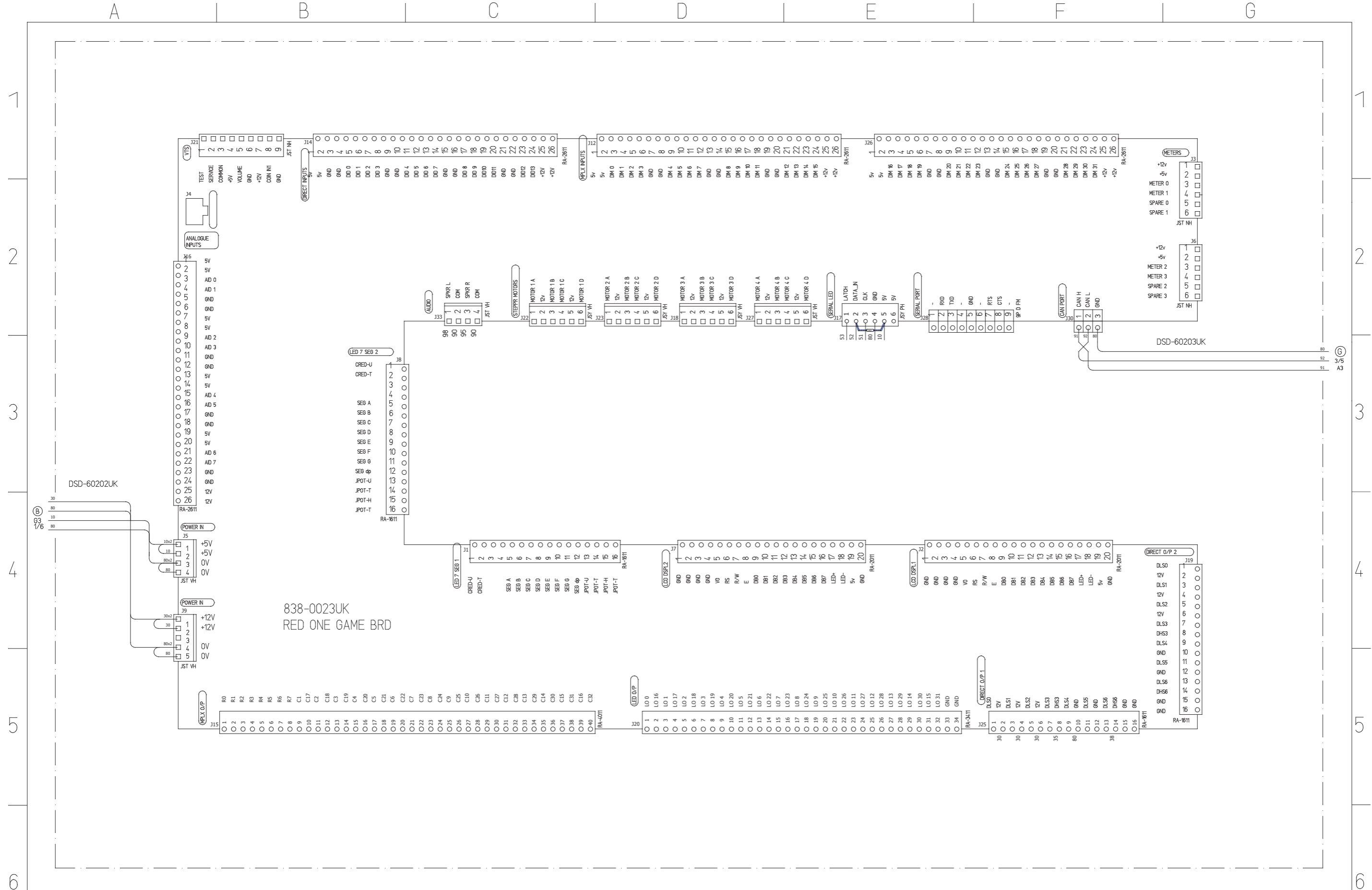

838-0023UK
RED ONE GAME BRD

| | | | | |
|---|--------|---|----|--------------|
| 8 | BLACK | | 43 | EARTH WIRE |
| 7 | ORANGE | E | 7 | AWG18 UL1672 |
| 5 | WHITE | D | 7 | AWG20 UL1672 |
| 4 | GREEN | C | U | AWG16 UL1015 |
| 3 | YELLOW | B | K | AWG18 UL1015 |
| 2 | BLUE | A | L | AWG20 UL1007 |
| 1 | RED | 9 | T | AWG22 UL1007 |
| | | | | AWG24 UL1007 |

| | | | |
|-------------|--|----|--|
| DRAWN | | RA | |
| PART NUMBER | | | |

SEGA AMUSEMENTS EUROPE LTD
SHOWDOWN SDX GANTRY

THIS DRAWING WILL IN NO WAY BE COPIED.
TO BE RETURNED ON DEMAND.

ORIGINAL SIZE
A2

ALTERATION

DESCRIPTION

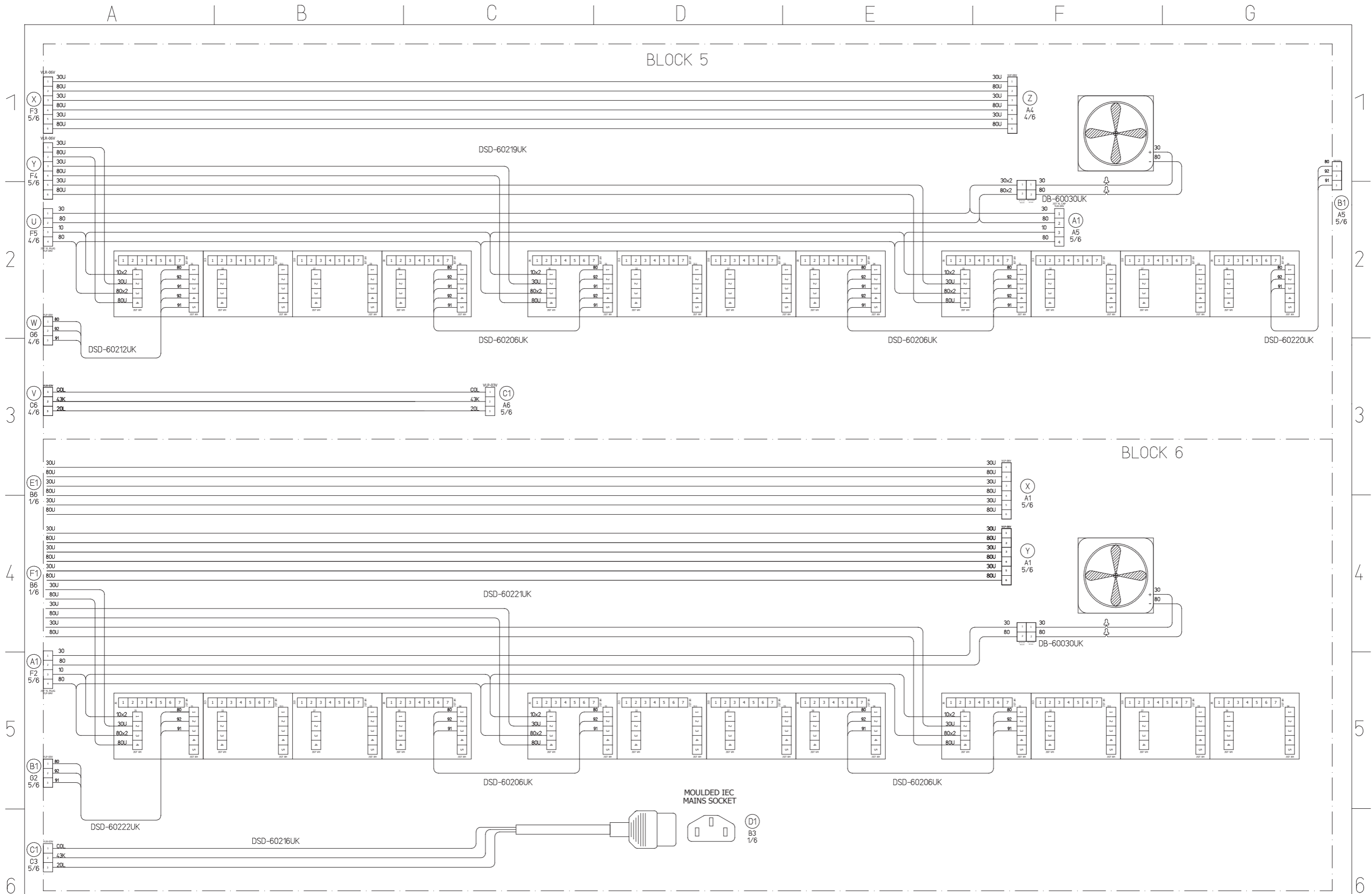

| | | | | | |
|---|--------|---|--------------|----|--------------|
| 8 | BLACK | E | LIGHT GREEN | 43 | EARTH WIRE |
| 7 | ORANGE | D | PURPLE | ? | AWG18 UL1672 |
| 5 | WHITE | U | AWG20 UL1672 | | |
| 4 | GREEN | C | BROWN | | AWG18 UL1015 |
| 3 | YELLOW | B | SKY BLUE | | AWG20 UL1007 |
| 2 | BLUE | A | PINK | | AWG22 UL1007 |
| 1 | RED | 9 | GRAY | | AWG24 UL1007 |

DRAWN
RA

SEGA AMUSEMENTS EUROPE LTD
SHOWDOWN SDX GANTRY

THIS DRAWING WILL IN NO WAY BE COPIED.
TO BE RETURNED ON DEMAND.

ORIGINAL SIZE
A2

ALTERATION

PART NUMBER

DESCRIPTION

A B C D F G

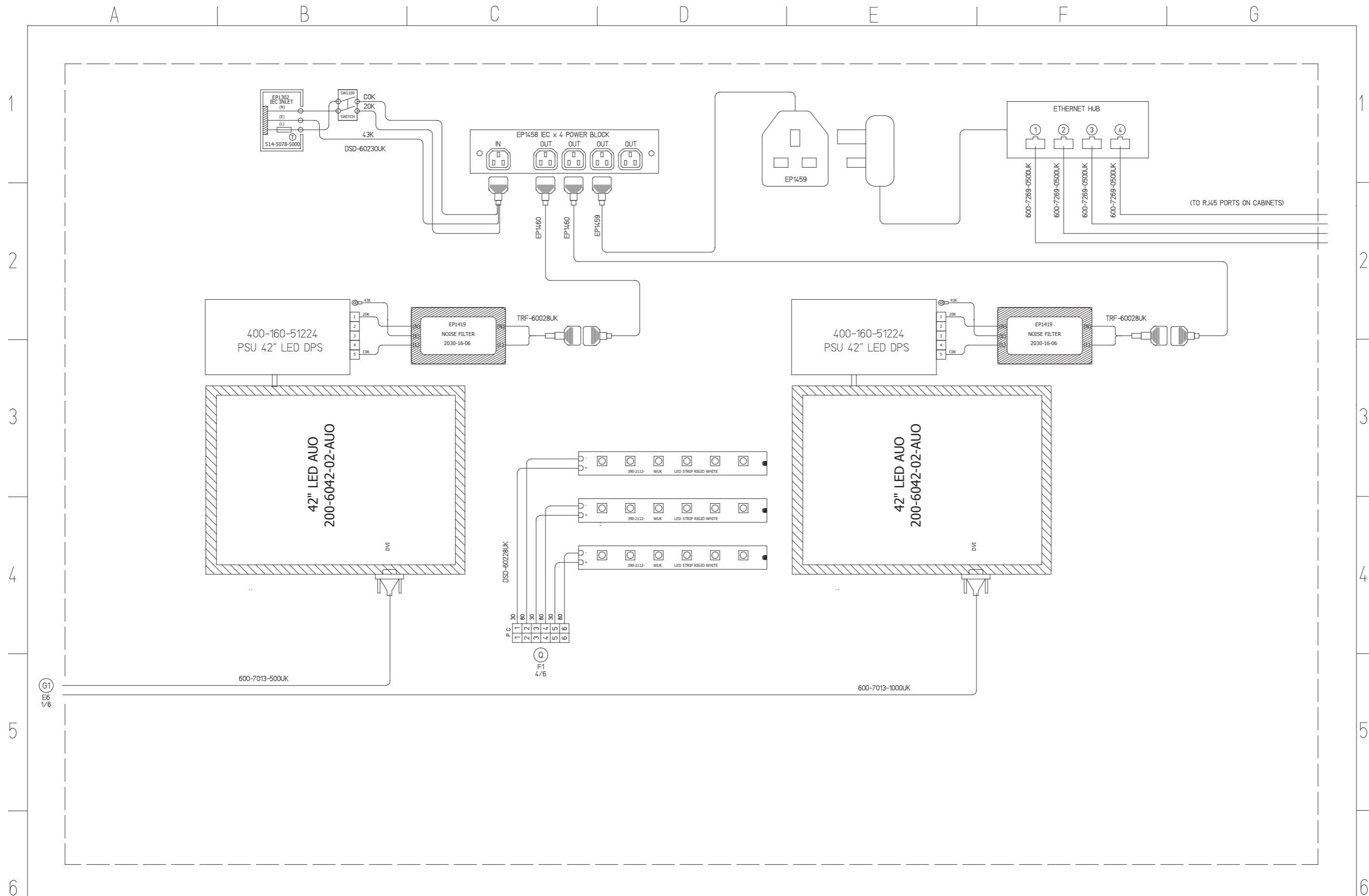

G1
E6
1/6

| | | | | | |
|----|--------|---|-------------|----|--------------|
| 8 | BLACK | E | LIGHT GREEN | 43 | EARTH WIRE |
| 7 | ORANGE | D | PURPLE | ? | AWG18 UL1672 |
| 5 | WHITE | C | BROWN | U | AWG16 UL1015 |
| 4 | GREEN | B | SKY BLUE | K | AWG18 UL1015 |
| 3 | YELLOW | A | PINK | L | AWG20 UL1007 |
| 2 | BLUE | 9 | GRAY | | AWG22 UL1007 |
| -1 | RED | | | T | AWG24 UL1007 |

| | | | | | |
|------------|--|--|--|--|--|
| ALTERATION | | | | | |
|------------|--|--|--|--|--|

| | |
|-------------|--|
| PART NUMBER | |
|-------------|--|

| | |
|-------|--|
| DRAWN | |
| RA | |

| | |
|----------------------------|-----------------------------------------------------------------|
| SEGA AMUSEMENTS EUROPE LTD | THIS DRAWING WILL IN NO WAY BE COPIED TO BE RETURNED ON DEMAND. |
| SHOWDOWN SDX GANTRY | ORIGINAL SIZE A2 |

| | |
|-------------|--|
| DESCRIPTION | |
|-------------|--|

A B C D E F G

- SEGA TOTAL SOLUTIONS -

42 Barwell Business Park
Leatherhead Road,
Chessington,
Surrey,
KT9 2NY
United Kingdom

Tel: +44 (0) 208 391 8060
Fax: +44 (0) 208 391 8096



Exclusive Suppliers of SEGA Spares

To Heathrow Airport

