

The Sega System.TM

Instruction Manual

SEGA[®]

Parts Identification

The Sega Connection

Connections to
TV/Monitor and Antenna

Powering Up the System

TV Channel Setting

Operating the System

Start, Pause and Reset

Troubleshooting Chart

Warranty

Parts Identification

SEGA SYSTEM

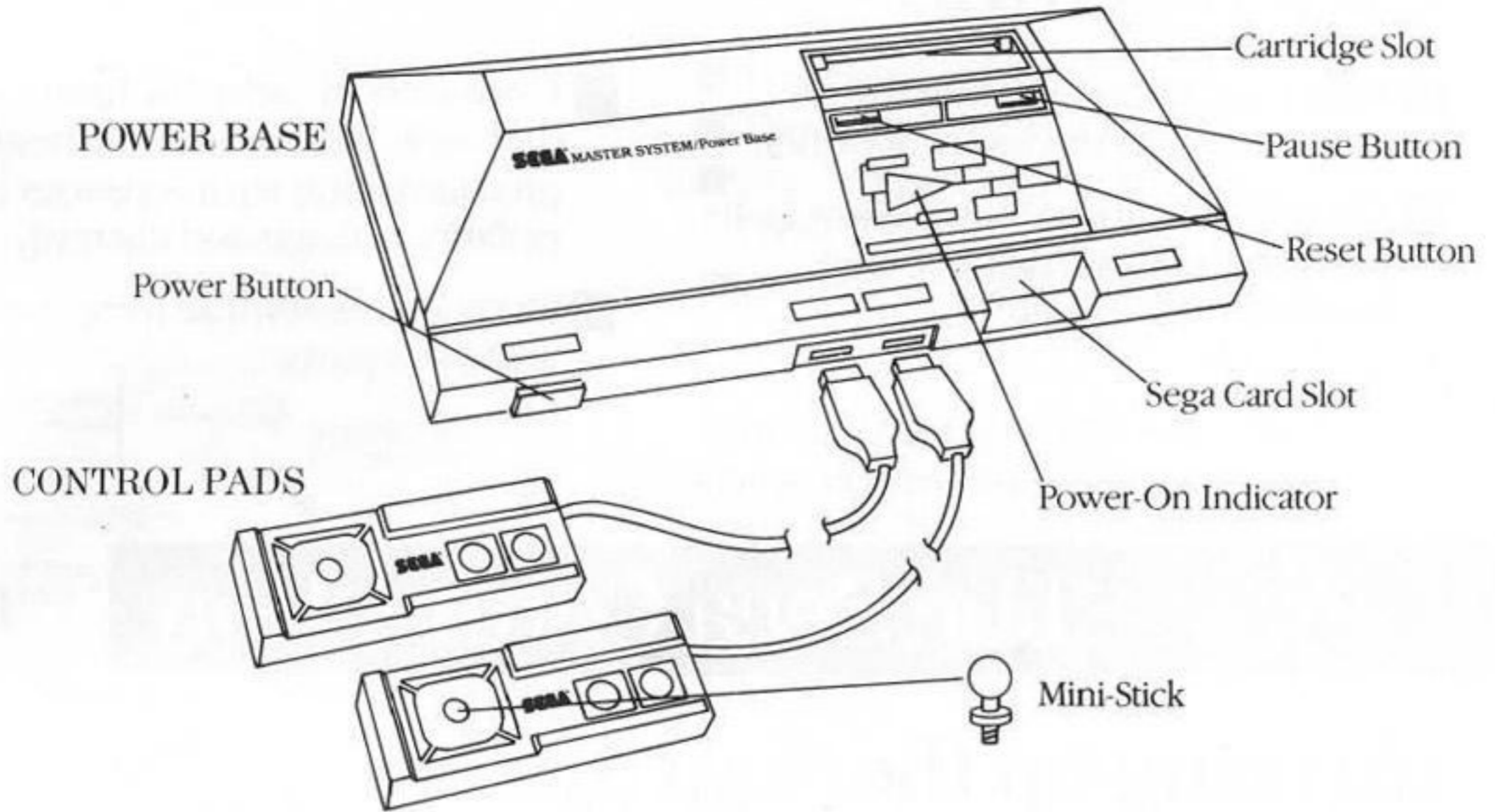

SEGA LIGHT PHASER (Optional)

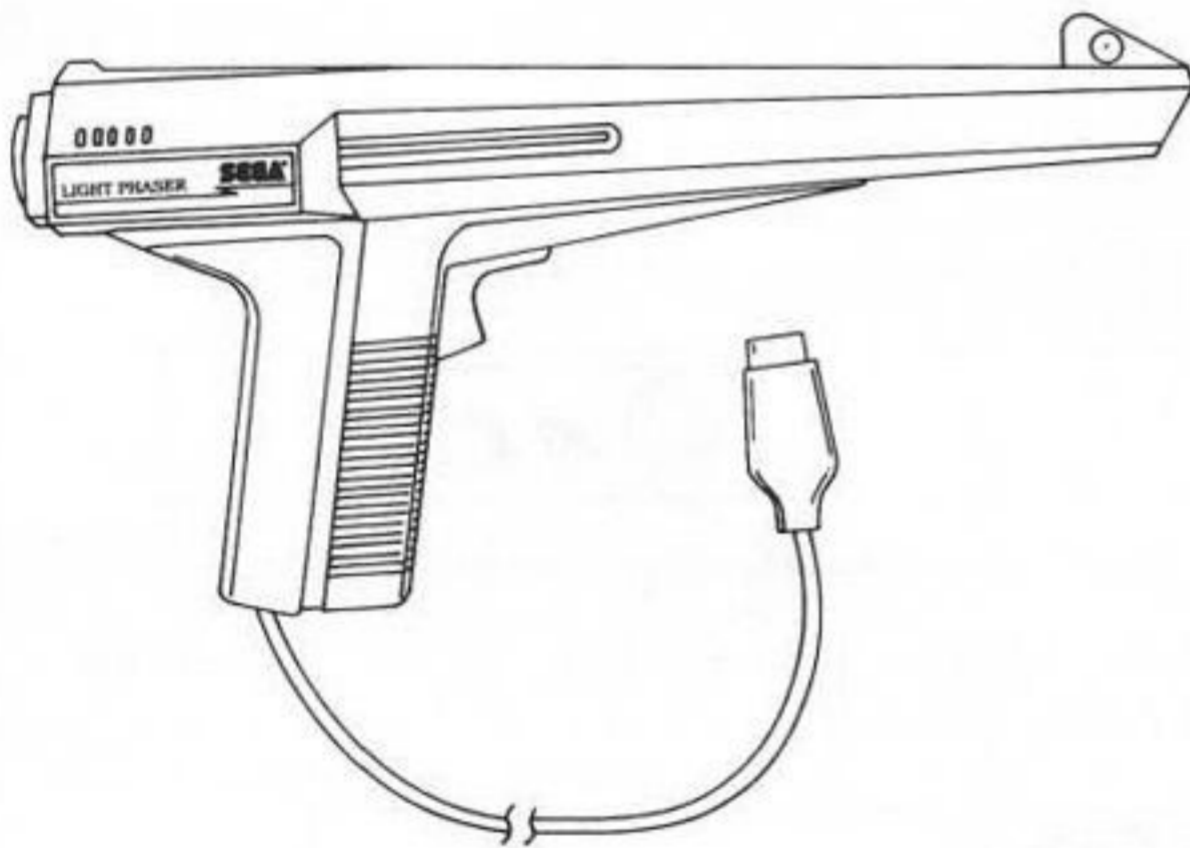

SEGA CARTRIDGE

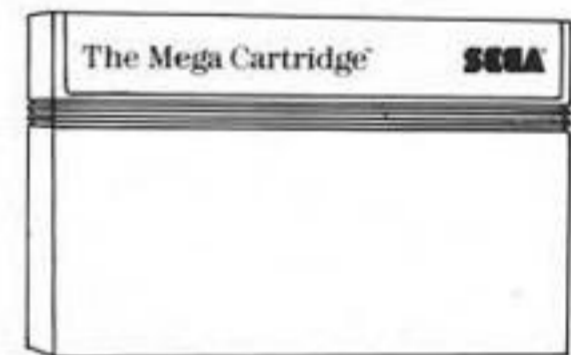

Auto RF Switch Box

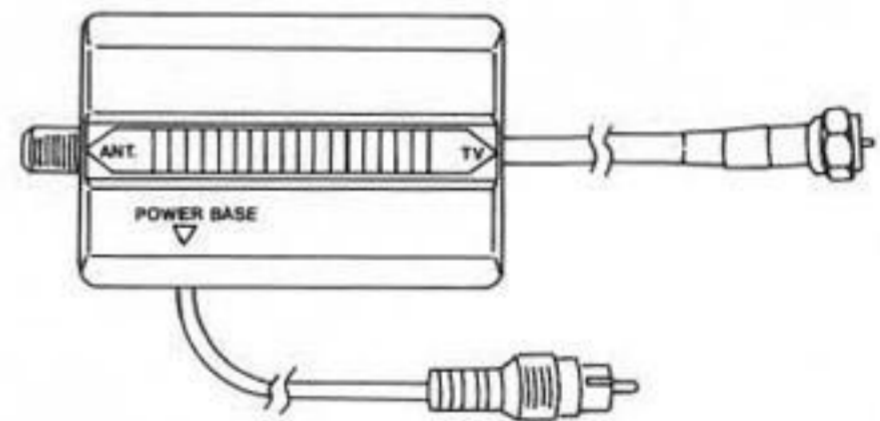

AC Adaptor

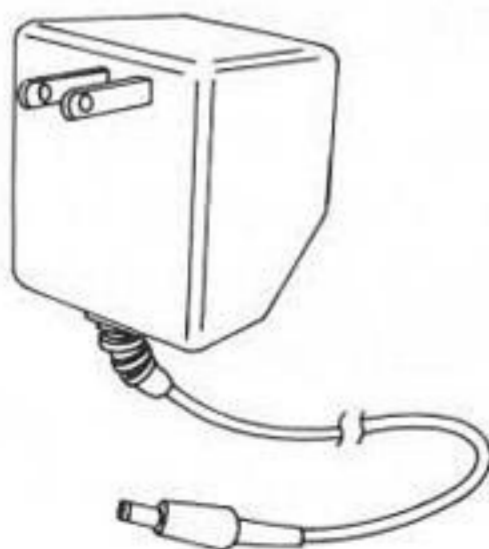

F-type Converter (300/75 ohm)



Matching Transformer (75/300 ohm)

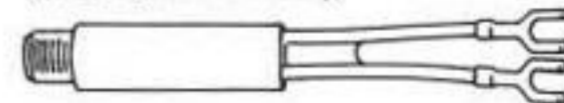

Video Cable



Precautions

- When not in use, unplug the AC adaptor from the electrical outlet.
- Do not leave the system or any of its parts in direct sunlight, in damp areas or near a heater.
- Use Sega's AC adaptor. Using different AC adaptor may result in problems due to differences in polarity, voltage and current.
- Do not disassemble the console or any of its parts.

The Sega Connection

Hooking-up the Sega System

BACK VIEW OF THE POWER BASE

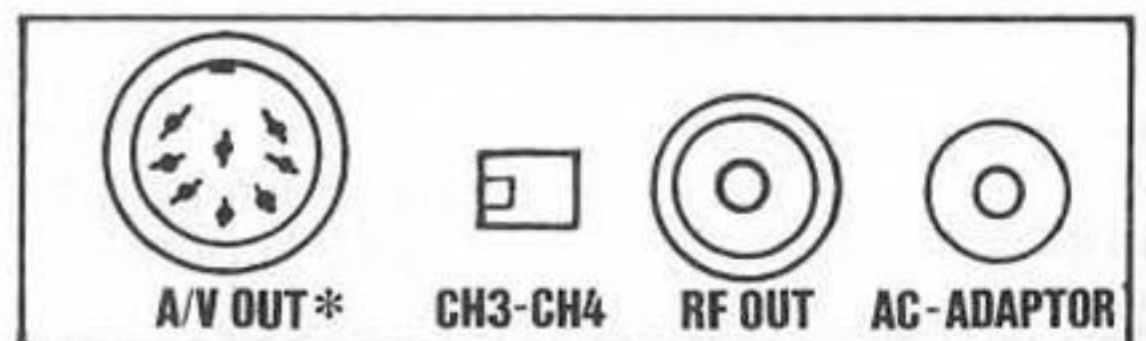
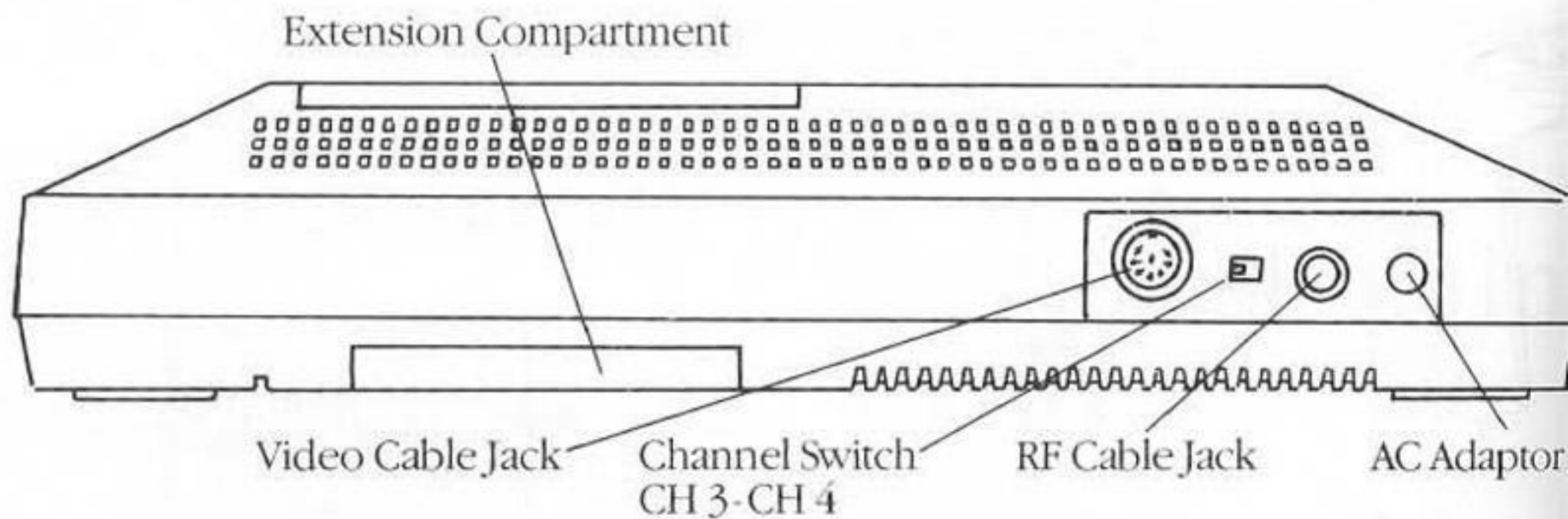

*Sega System Power Base comes equipped with RGB analog output for use with specialized monitor with RGB analog input. For information regarding its use, call Sega Consumer Services.

Connections to TV/Monitor and Antenna.

There are various types of TV sets and antenna terminals. For this reason, we've provided *four different types of connectors*:

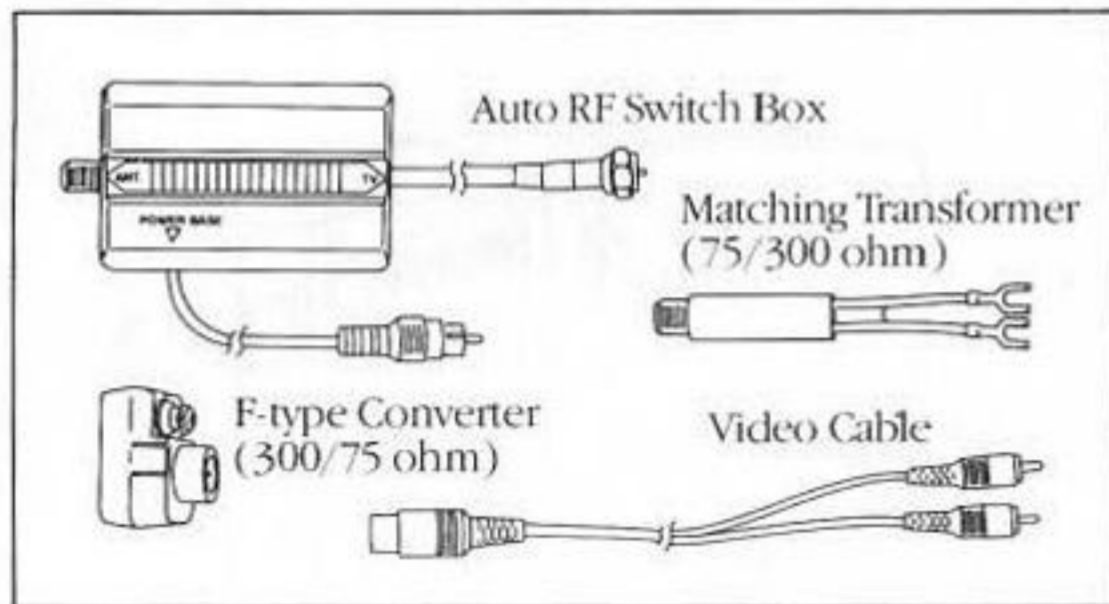

- The video cable
- The auto RF switch box
- The F-type Converter (300/75 ohm)
- The Matching Transformer (75/300 ohm)

You will not need to use *all* of these connectors. Compare your TV with the illustrations below to decide which procedure is necessary.

TV with video and audio input jacks

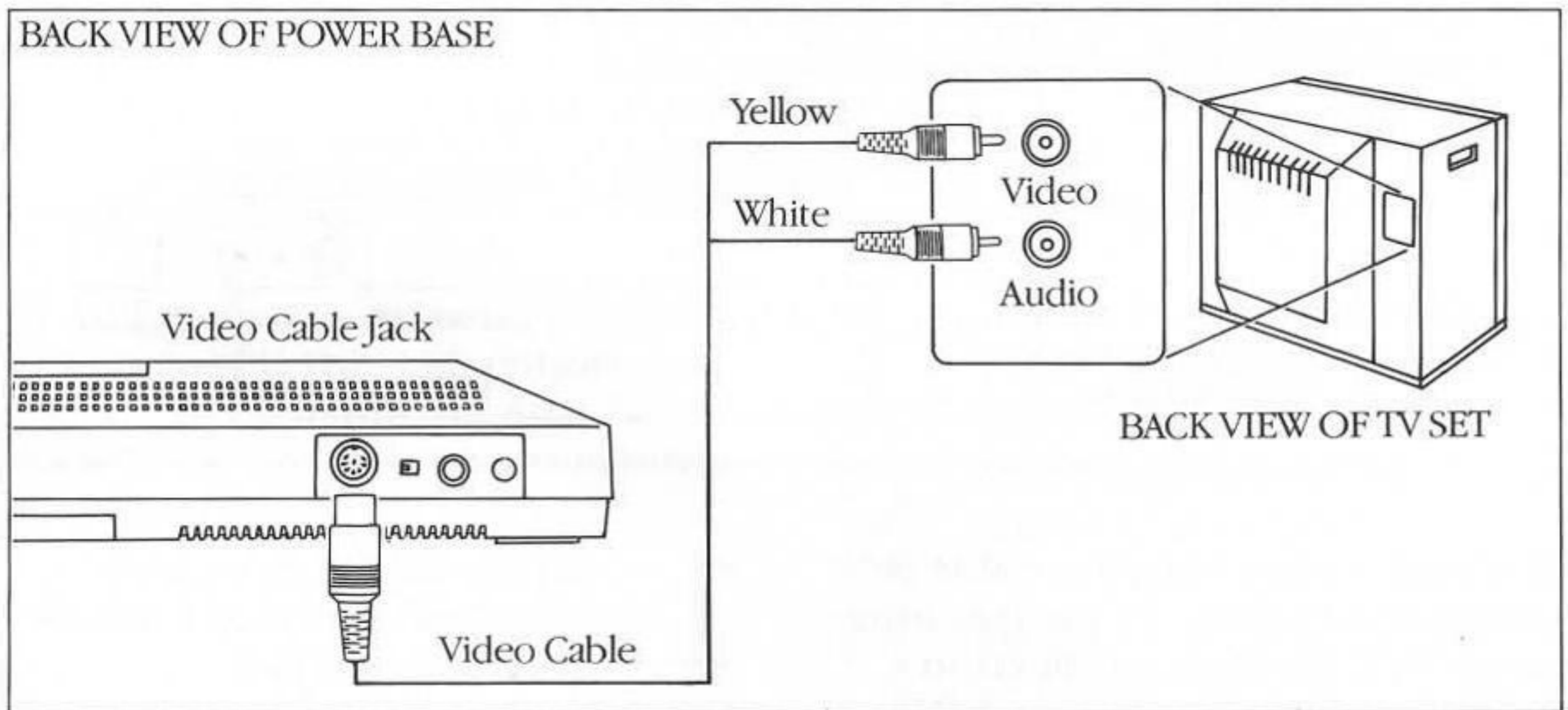

If your TV has video and audio input jacks (usually in the back of recent-model TV's), the Sega connection can be made simply by using the video cable. No other connectors are necessary.

1. Insert the single-plug end of the Video Cable into the Video Cable Jack on the Power base.
2. Insert the yellow plug on the Video Cable into the TV's video input. Insert the white plug into the TV's audio input.

If your TV does *not* have video and audio inputs, use one of the following procedures:

TV with single-plug antenna cable (for either cable TV or VHF antenna cable)

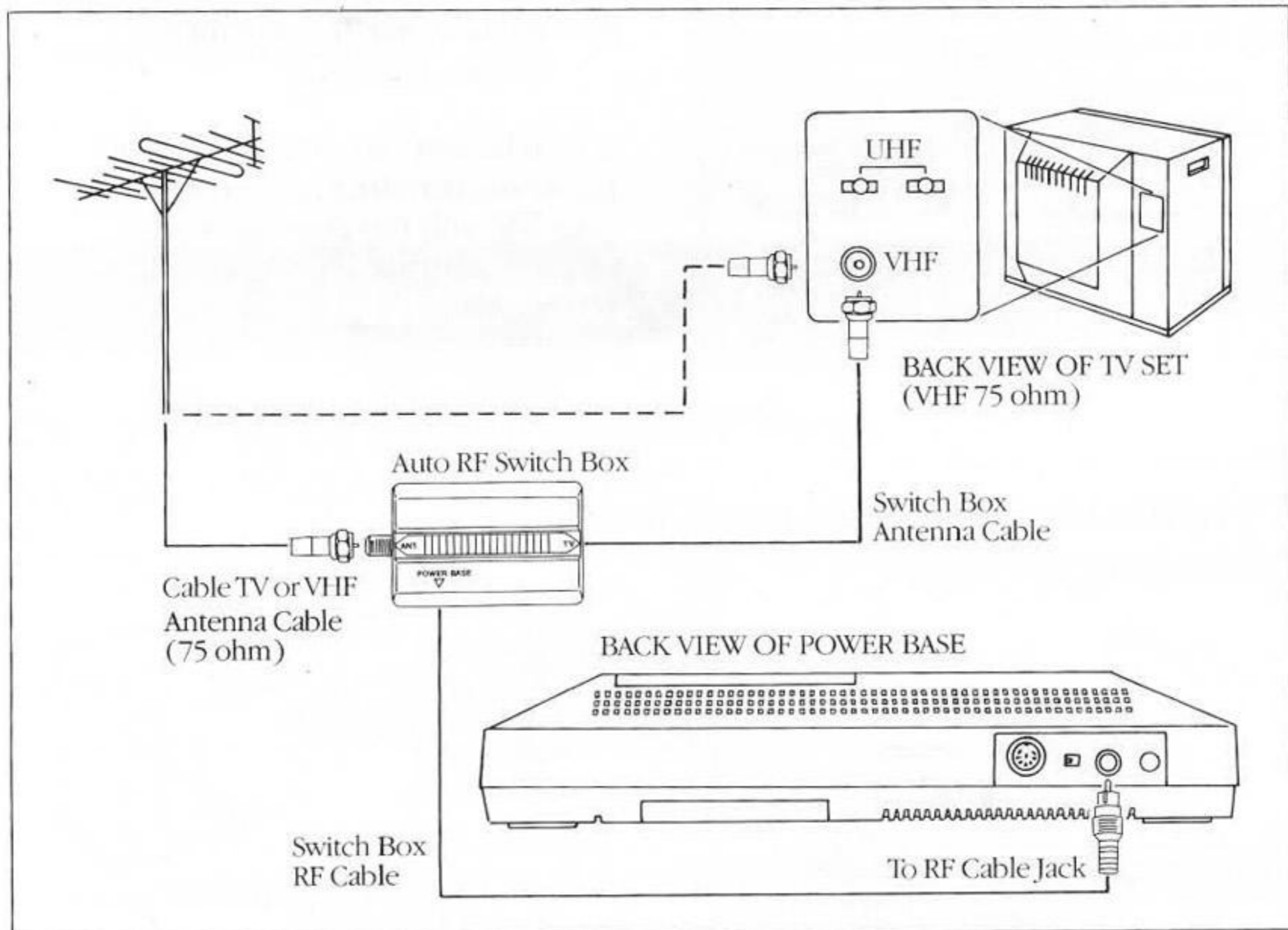

If a single-plug antenna cable is plugged into your TV (or you have cable TV), the Sega connection can be made using the Auto RF Switch Box. No other connectors are necessary.

- 1.** Unplug the Antenna Cable from the TV, and plug it into the Auto RF Switch Box.
- 2.** Now, plug the Switch Box Antenna Cable into the TV.
- 3.** Finally, plug the Switch Box RF Cable into the RF Cable Jack on the back of the power base.

TV with F-type converter

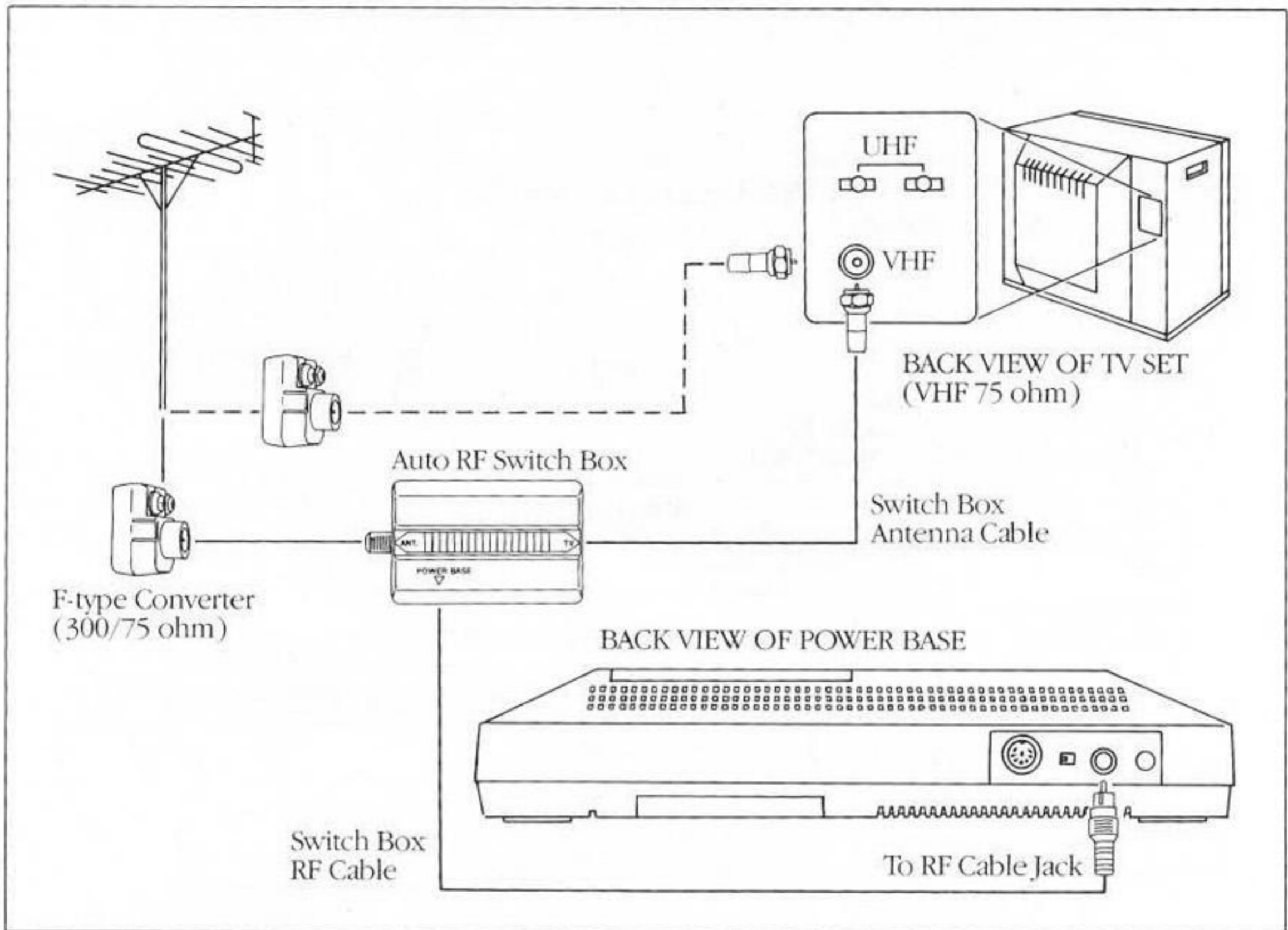

If an F-type converter is plugged into your TV, the Sega connection can be made using the Auto RF Switch Box. No other connectors are necessary.

- 1.** Unplug the F-type Converter from the TV, and plug it into the Auto RF Switch Box.
- 2.** Now, plug the Switch Box Antenna Cable into the TV.
- 3.** Finally, plug the Switch Box RF Cable into the RF Cable Jack on the back of the power base.

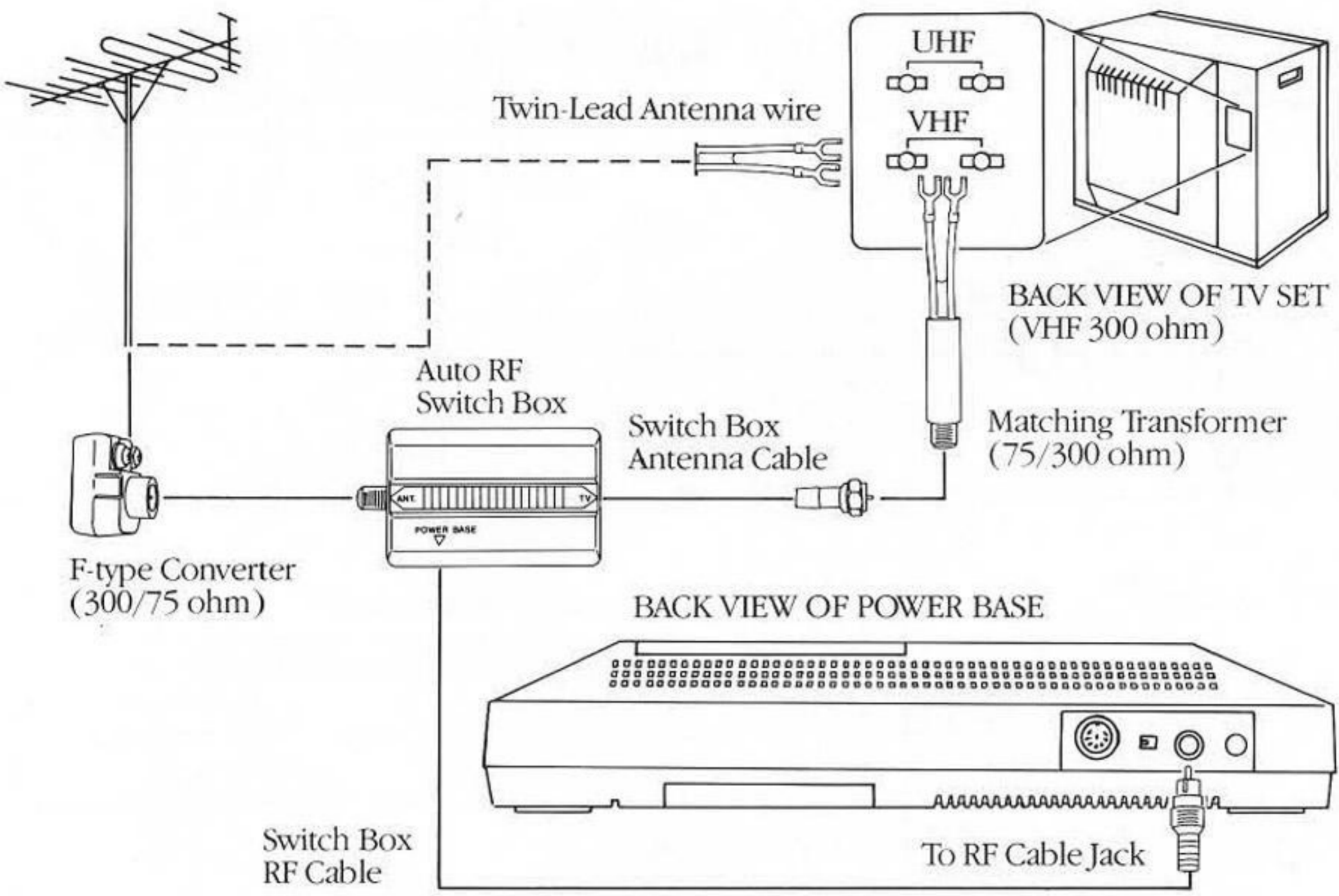

the antenna cable consists of Twin-Lead Antenna wire connected to your TV, the Sega connection can be made using the Matching transformer, F-type Converter and Auto RF Switch Box.

- 1.** Disconnect the Twin-Lead Antenna wire from the TV, and connect them to the F-type Converter.
- 2.** Plug into the Auto RF Switch Box.
- 3.** Plug the Switch Box Antenna Cable into the Matching Transformer. Then, connect the Transformer's Twin-Lead Antenna wire to the back of the TV.
- 4.** Finally, plug the Switch Box RF Cable into the RF Cable Jack on the back of the power base.

TV with cable TV or VHF antenna cable plugged into matching transformer.

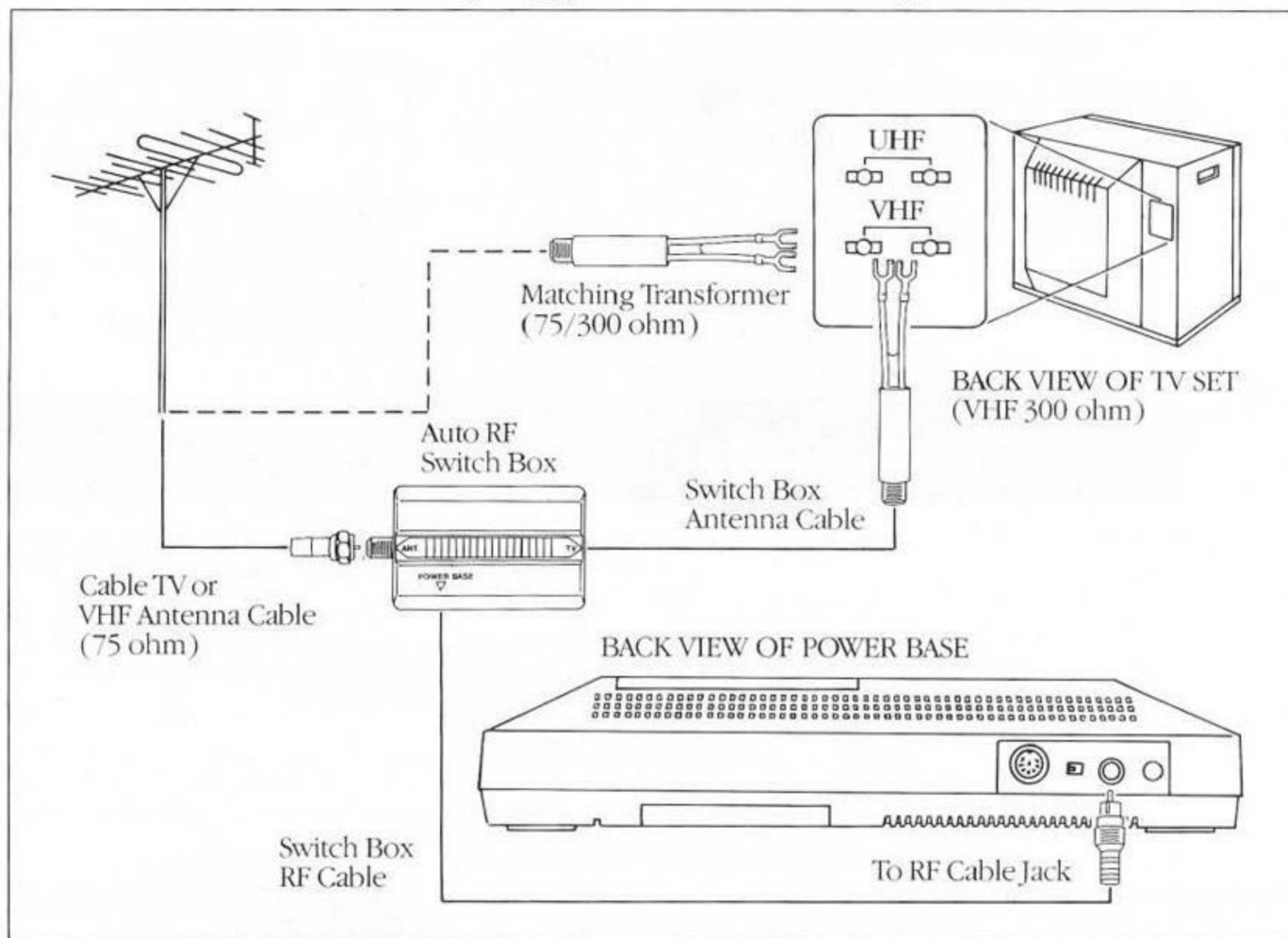

If cable TV or a VHF antenna cable is already plugged into a matching transformer at the back of your TV, the Sega connection can be made using the Auto RF Switch Box with the already-present matching transformer.

- 1.** Leave the Twin-Lead Antenna wire of the Matching Transformer connected to the TV. Unplug the VHF Antenna Cable from the other end of the Transformer.
- 2.** Now, plug the VHF Antenna Cable into the Auto RF Switch Box.
- 3.** Plug the Switch Box Antenna Cable into the Matching Transformer.
- 4.** Finally, plug the Switch Box RF Cable into the RF Cable Jack on the back of the power base.

TV with connected video cassette recorder

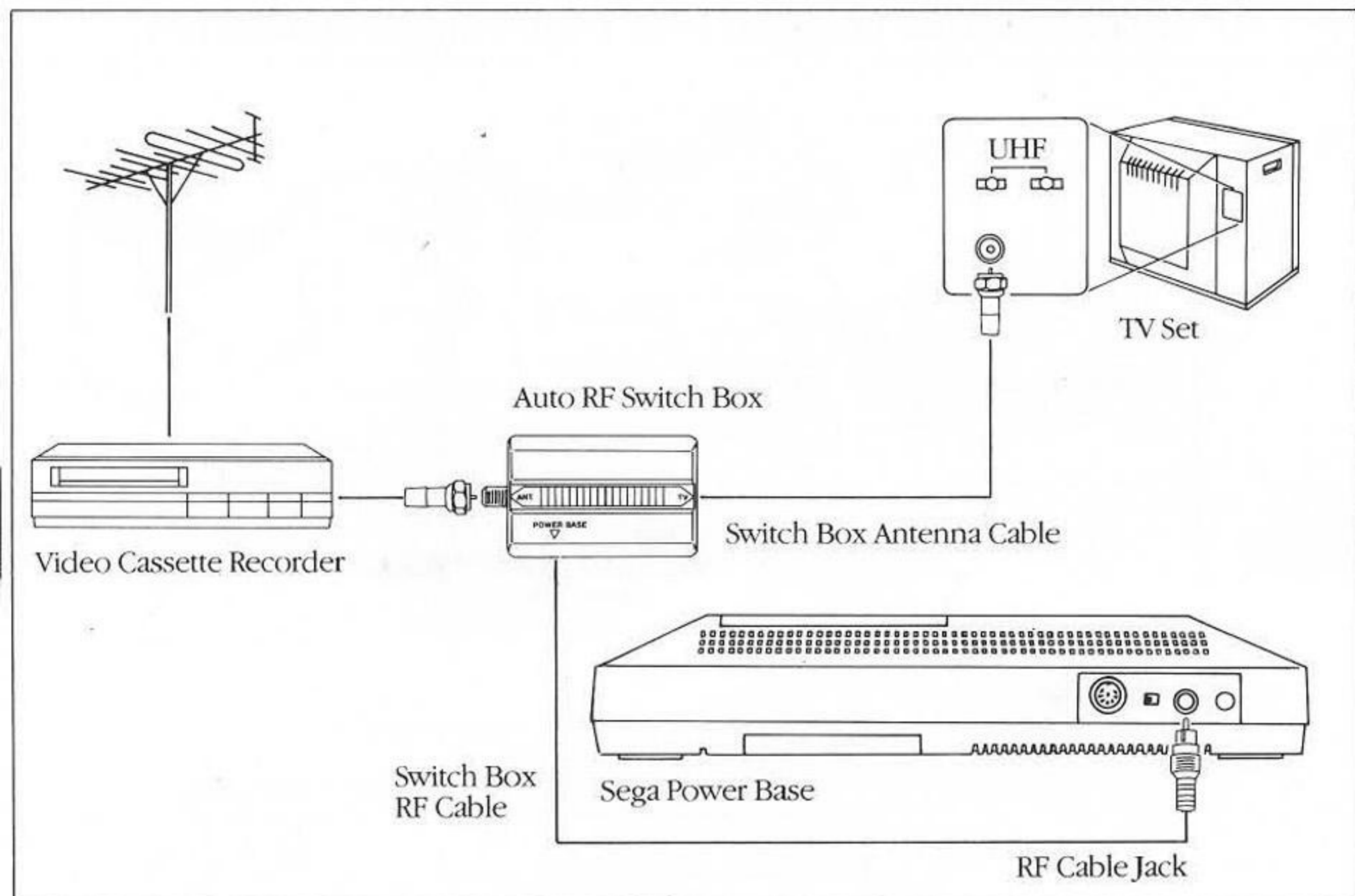

If a video cassette recorder is already connected between the antenna and the television's VHF terminals, the Sega connection can be made using the Auto RF Switch Box (and, if necessary, the F-type converter and/or the Matching Transformer).

- 1.** Disconnect the Video Cassette Recorder Cable from the television's VHF terminal (or from its Matching Transformer). Then, plug this same cable into the Auto RF Switch Box. (If this cable has a Twin-Lead Antenna wire, use the F-type Converter to make this connection.)
- 2.** Now, plug the Switch Box Antenna Cable into the television's VHF terminal. (If a Twin-Lead Antenna wire is required, use the Matching Transformer to make this connection.)
- 3.** Finally, plug the Switch Box RF Cable into the RF Cable Jack on the back of the power base.

NOTE: If there is a UHF cable connection, leave it as it is.

Powering Up the System

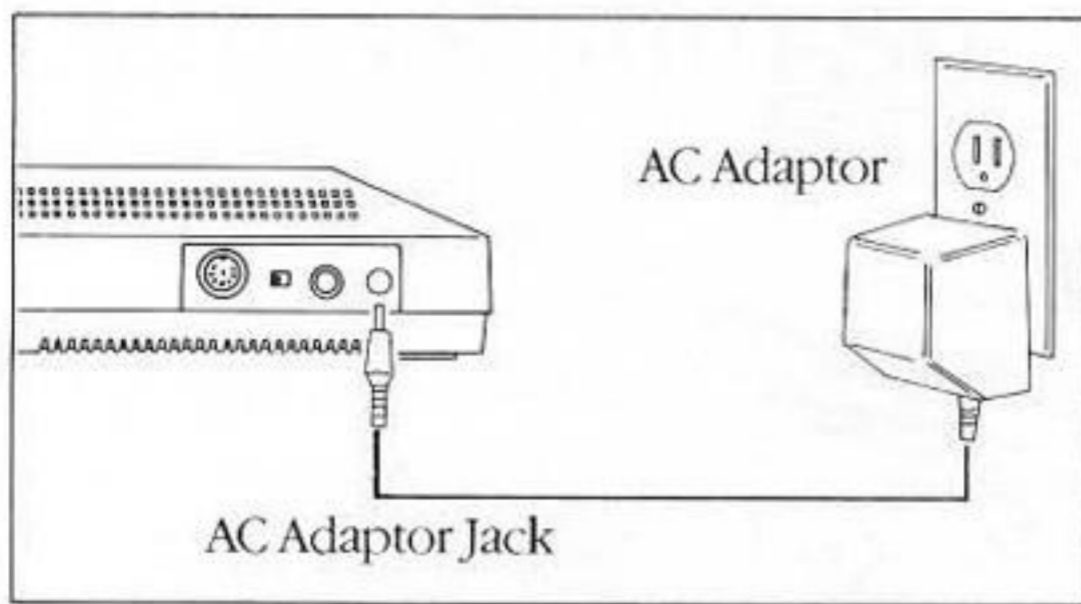

- Connect the AC Adaptor Plug to the Power-In Jack of the power base.
- Plug the AC Adaptor into an electrical outlet.

TV Channel Setting

BACK VIEW OF POWER BASE

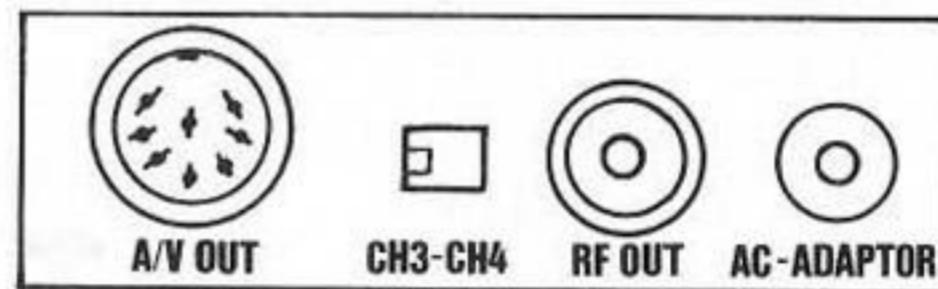
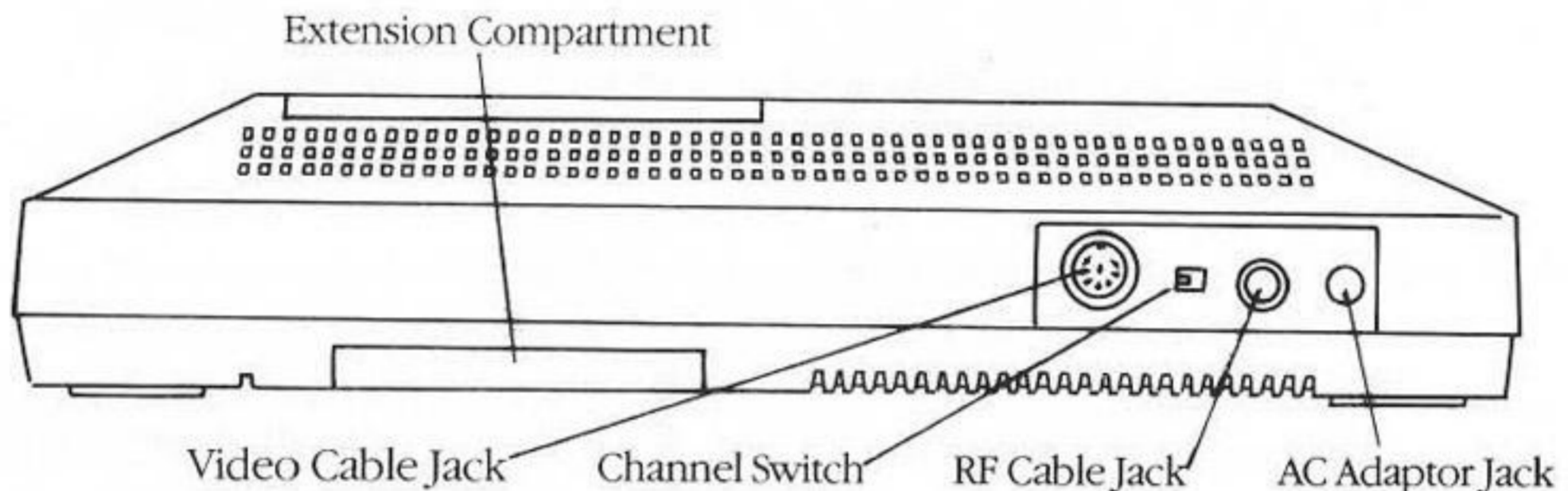

1. Set the Channel Switch on the back of the power base to CH 3 (low).
2. Set your TV to Channel 3. (If you have a late-model TV with several video inputs, set the channel to E3, or external video input 3.)
3. If channel 3 is used for broadcasting, set your TV to channel 4. Then, be sure to switch the Channel Switch on the power base to CH 4 (high).
4. If your TV has an automatic fine tuning control (AFC), turn it off and manually adjust the picture. However, if you have a color TV that turns black and white when the AFC is turned off, leave the AFC on.

Operating the System

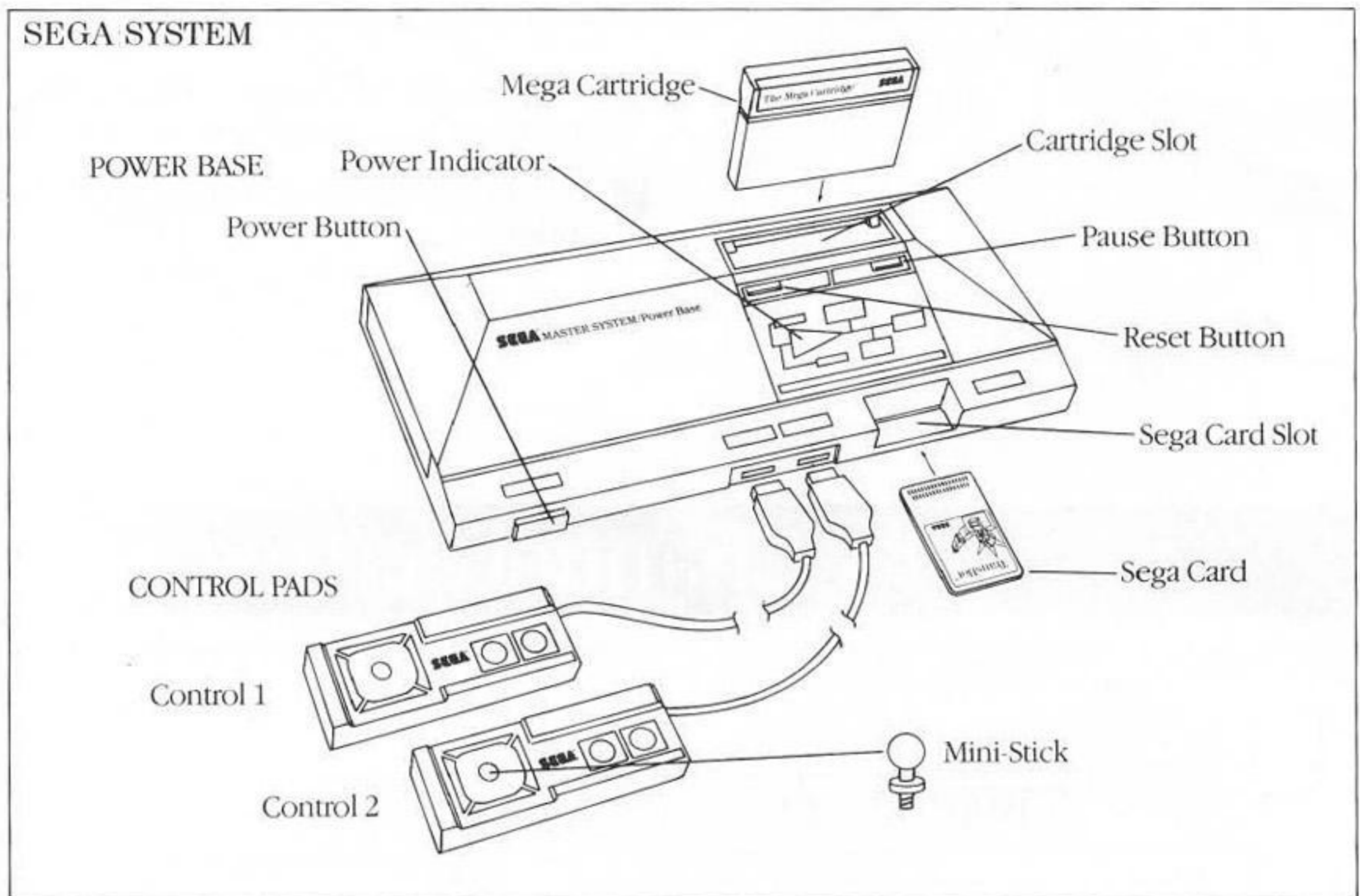

1. Plug a control pad into "Control 1" on the power base. If the light phaser accessory is to be used (optional), plug the light phaser cord into "Control 1." For two players, use both control pads, and plug them into Control 1 and 2.

2. Press the power button **off**. Be sure the power light is not on. **Never insert or remove a cartridge or Sega Card while the power is on.**

3. When you are using a Mega Cartridge, insert it, label facing forward, into the cartridge slot. Press it fully into the slot.

4. When you are using a Sega Card, insert the card, label side up, facing away from you, into the Sega Card slot.

NOTE: A Sega Card and a Mega Cartridge cannot be used simultaneously.

5. Press the power button **on**. The power light should turn on.

6. If all connections have been properly made, the Sega logo will appear, followed by the title screen and, in some cases, a demonstration of the game.

Optional Mini-Stick

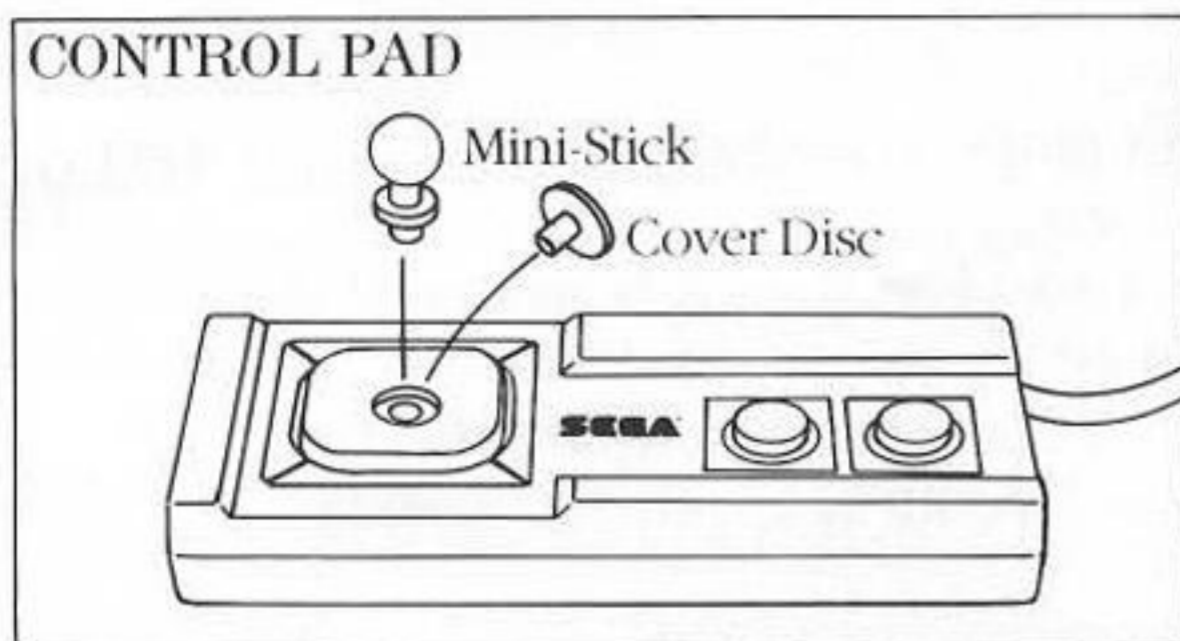

- Hold down outer rim of control cushion.
- Remove round cover disk from center with fingernail.
- Screw in mini-stick.

Start, Pause and Reset

1. To start the game, press button #1, on Control Pad 1. For two players, press button #1 on Control Pad 2.

2. To reset the game to the beginning, press the Reset Button on the power base. You will return to the title screen.

3. To pause the action, press the Pause Button on the power base. To resume the action, press it again.

4. To resume regular TV broadcasting, turn off the power base, change the channel on the TV.

For individual game instruction, refer to the manual that comes with your Sega Card or Cartridge.

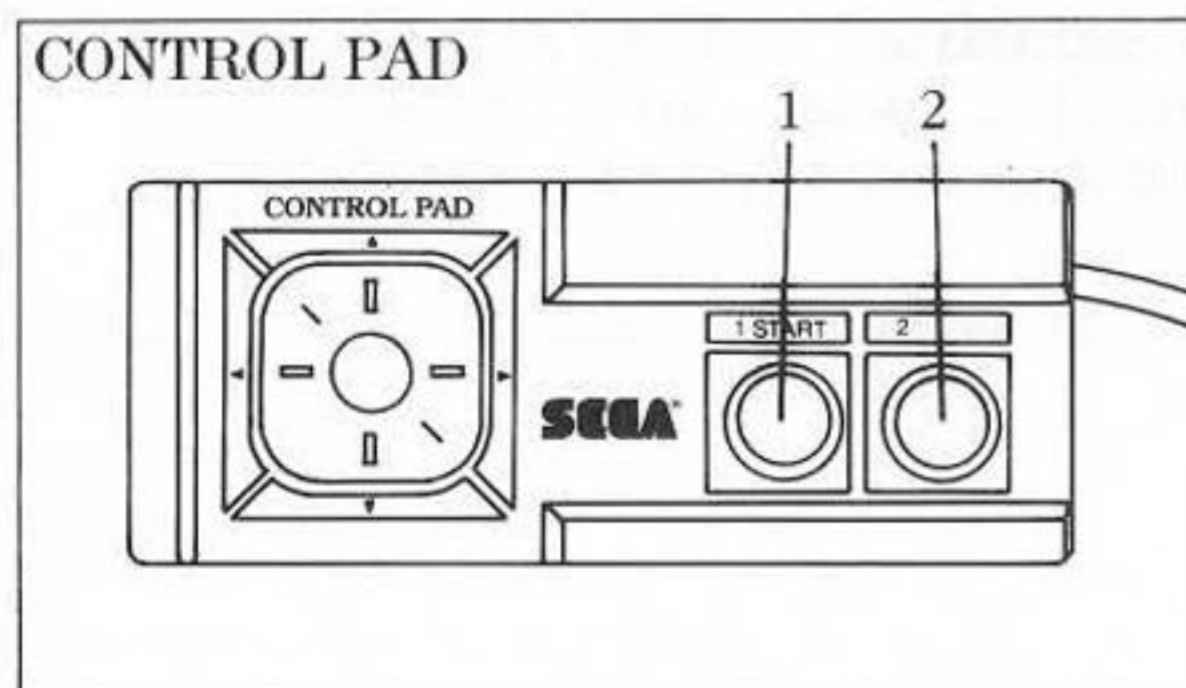

Troubleshooting Chart

The Sega System

Problem	Before requesting repair, check the following items:
No picture on screen	<ul style="list-style-type: none">■ Is the power base turned on?■ Is the AC adaptor properly plugged in?■ Is the TV turned on?■ Does the power base channel switch agree with the TV channel being used?■ Is the Sega cartridge or card properly inserted?■ Have you confused the RF Jack with the Video or Power-In Jacks?■ Review the connections between the antenna cable, power base and TV terminals.
Screen flickers or no color	<ul style="list-style-type: none">■ Are the antenna cables properly connected?■ Is the TV channel fine adjustment properly set?■ Are the TV color controls properly set?■ Is the Sega cartridge or card properly inserted?
No game sound	<ul style="list-style-type: none">■ Is the TV volume too low or off?■ Have the connection cables come loose or gotten disconnected?
Picture on TV screen is not steady	<ul style="list-style-type: none">■ Make sure that the TV synchronization settings (vertical and horizontal) are correct.
Fringes appear on TV during game	<ul style="list-style-type: none">■ Adjust the manual fine adjustment controls on the TV.
Fringes appear on TV during a broadcast	<ul style="list-style-type: none">■ Is the antenna cable properly connected?■ Make sure that you have turned off the power on the power base.
TV screen reads "SOFTWARE ERROR"	<ul style="list-style-type: none">■ Call Sega Customer Service to determine whether game is defective or improperly duplicated.
<p>If you continue to have a problem, use this manual to carefully re-connect the system, step by step. If the problem still exists, please call the Sega Customer Service Department. Outside California call 1-800-USA-SEGA Inside California call (415) 742-9300</p>	

90-Day Limited Warranty

To validate the following 90-day limited warranty, your warranty card and sales slip or proof of purchase should be completed and returned to Sega within 10 days after date of purchase.

90-Day Limited Warranty

Sega of America, Inc. warrants to the original consumer purchaser that the Sega System and all component parts* shall be free from defects in material and workmanship for a period of 90 days from the date of purchase. If defect covered by this warranty occurs during this 90-day warranty period, Sega will repair or replace the defective system or component part, at its option, free of charge.

This warranty does not apply if the defects have been caused by negligence, accident, unreasonable use, modification, tampering, or any other causes not related to defective materials or workmanship. Additionally, this warranty shall not be valid if the serial number of the Sega has been altered, defaced, or removed in any way.

To receive fast, reliable warranty service, call the Sega Customer Service Department at the following numbers:

Outside California State (800) USA-SEGA

Inside California State (415) 742-9300

Our Customer Service Department is in operation from 9:00 a.m. to 5:00 p.m. (Pacific Time), Monday through Friday. *Do not return your Sega System to your retail seller.*

If the Sega technician is unable to solve the problem by phone, we will provide you with instructions on returning your defective system to us. The cost of returning the system to Sega's service center shall be paid by the purchaser.

Sega's service center is located at the following address:

SEGA OF AMERICA, INC.

573 Forbes Blvd.

South San Francisco, CA 94080

Repairs After Expiration of Warranty

If your Sega System requires repairs after termination of the 90-day warranty period, you may contact the Sega Customer Services Department at the number listed above. If the technician is unable to solve the problem by phone, he will advise you of the estimated cost of repair. If you elect to have the repair done, you will need to return the defective merchandise, freight prepaid, to Sega's service center with an enclosed check or money order payable to Sega of America, Inc. for the amount of the cost estimate provided to you by the technician. If, after inspection, it is determined that your merchandise cannot be repaired, it will be returned to you and your payment will be refunded.

Limitations on Warranty

Any applicable implied warranties, including warranties of merchantability and fitness for a particular purpose, are hereby limited to ninety days from the date of purchase and are subject to the conditions set forth herein. In no event shall Sega of America, Inc. be liable for consequential or incidental damages resulting from the breach of any express or implied warranties.

The provisions of this warranty are valid in the United States only. Some states do not allow limitations on how long an implied warranty lasts or exclusion of consequential or incidental damages, so the above limitation or exclusion may not apply to you. This warranty provides you with specific legal rights. You may have other rights which vary from state to state.

*Components (including model numbers) covered under this warranty are: Sega Power Base, two controller pads, Mega Cartridge, AC adapter, auto RF switch box, transformers and F type converter.

Compliance With FCC Regulations

This equipment generates and uses radio frequency energy and if not installed and used properly, that is, in strict accordance with the manufacturer's instructions, may cause interference to radio and television reception. It has been type tested and found to comply with the limits for a Class B computing device in accordance with the specifications in Subpart J of Part 15 of FCC Rules, which are designed to provide reasonable protection against such interference in a residential installation. However, there is no guarantee that interference will not occur in a particular installation. If this equipment does cause interference to radio or television reception, which can be determined by turning the equipment off and on, the user is encouraged to try to correct the interference by one or more of the following measures:

- Reorient the receiving antenna
- Relocate the SEGA System with respect to the receiver
- Move the SEGA System away from the receiver
- Plug the SEGA System into a different outlet so that the SEGA System and Receiver are on different branch circuits

If necessary, the user should consult the dealer or an experienced radio/television technician for additional suggestions. The user may find the following booklet prepared by the Federal Communications Commission helpful: "How to Identify and Resolve Radio-TV Interference Problems." This booklet is available from the U.S. Government Printing Office, Washington, D.C., 20402, Stock No. 004-000-00345-4.

Now, there are no limits.SM

SEGA[®]

SEGA OF AMERICA, INC., 573 Forbes Blvd., South San Francisco, CA 94080, (415) 742-9300
A CSK GROUP COMPANY

© 1986 SEGA OF AMERICA, INC.
Printed in Japan