

420-0019UK  
1<sup>st</sup> PRINTING



Sega Amusements Europe Limited.  
42 Barwell Business Park, Leatherhead Road, Chessington, Surrey, KT9 2NY, United Kingdom.  
Telephone: +44 (0) 208 391 8090 Facsimile: +44 (0) 208 391 8099  
email: mailbox@sega.co.uk Web: <http://www.sega-amusements.co.uk>

PLAY IT AMUSEMENTS inc.  
252 Beinoris Drive, Wood Dale, IL. 60191, U.S.A  
Telephone: 1-847-364-9787 Toll Free: 1-888-877-2669  
Facsimile: 1-847-427-1065

© SEGA

K.O DRIVE

OWNER'S MANUAL

420-0019UK



## OWNER'S MANUAL



### IMPORTANT

- Before using this product, read this manual carefully to understand the contents herein stated.
- After reading this manual, be sure to keep it near the product or in a convenient place for easy reference when necessary.

# BEFORE USING THE PRODUCT, BE SURE TO READ THE FOLLOWING:

## To maintain safety:

To ensure the safe operation of this product, be sure to read the following before usage. The following instructions are intended for the users, operators and the personnel in charge of the operation of the product. After carefully reading and sufficiently understanding the warning displays and cautions, handle the product appropriately. Be sure to keep this manual close to the product or in a convenient place for future reference.

Herein, explanations which require special attention are enclosed with dual lines. Depending on the potentially hazardous degrees, the terms of DANGER, WARNING, CAUTION, etc. are used. Be sure to understand the contents of the displays before reading the text.

 **DANGER** Indicates that mishandling the product by disregarding this pictograph will cause severe injury or death.

 **WARNING** Indicates that mishandling the product by disregarding this warning will cause a potentially hazardous situation which can result in death or serious injury.

 **CAUTION** Indicates that mishandling the product by disregarding this caution will cause a slight hazardous situation which can result in personal injury and/or material damage.

## For the safe usage of the product, the following pictographs are used:



Indicates "HANDLE WITH CARE." In order to protect the human body and equipment, this display is attached to places where the instruction manual should be referred to.



Indicates a "protective earth terminal." Before operating the equipment, be sure to connect it to the ground.  
(The step may be omitted for products in which a power cable with earth is used.)

- **Perform work in accordance with the instructions herein stated.**  
Instructions for work are explained by paying attention to the aspect of accident prevention. Failing to perform work as per the instructions can cause accidents. In the case where only those who have technical expertise should perform the work to avoid hazardous situation, the instructions herein state that the site maintenance personnel should perform such work.
- **Be sure to turn off the power before working on the machine.**  
To prevent an electric shock, be sure to turn off the power and unplug the power cable before carrying out any work that requires direct contact with the interior of the product. If the work is to be performed in the power-on status, the instruction manual herein always states to that effect.
- **Be sure to ground the earth terminal.**  
**(This is not required in the case where a power cable with earth is used.)**  
This product is equipped with the earth terminal. When installing the product, connect the earth terminal to the "accurately grounded indoor earth terminal" by using an earth wire. Unless the product is grounded appropriately, the user can be subject to an electric shock. After performing repair, etc. for the control equipment, ensure that the earth wire is firmly connected to the control equipment.
- **Ensure that the power supply used is equipped with an earth leakage breaker.**  
Using a power supply which is not equipped with the earth leakage breaker can cause a fire when earth leakage occurs.
- **Be sure to use fuses which meet the specified rating.**  
**(Only for the machines which use fuses.)**  
Using fuses exceeding the specified rating can cause a fire and an electric shock.

- **Specification changes (removal of equipment, conversion and addition) not designated by SEGA are not allowed.**

The parts of the product include warning labels for safety, covers for personal protection, etc. It is very hazardous to operate the product by removing parts and/or modifying the circuits. Should doors, lids and protective parts be damaged or lost, refrain from operating the product, and contact where the product was purchased from or the office herein stated.

SEGA shall not be held responsible for any accidents, compensation for damage to a third party, resulting from the specifications not designated by SEGA.

- **Ensure that the product meets the requirements of appropriate electrical specifications.**

Before installing the product, check for electrical specifications. SEGA products have a nameplate on which electrical specifications are described. Ensure that the product is compatible with the power supply voltage and frequency requirements of the location. Using any electrical specifications different from the designated specifications can cause a fire and an electric shock.

- **Install and operate the product in places where appropriate lighting is available, allowing warning labels to be clearly read.**

To ensure safety for the customers, labels and printed instructions describing potentially hazardous situations are applied to places where accidents can be caused. Ensure that where the product is operated has sufficient lighting allowing the warnings to be read. If any label is peeled off, apply it again immediately. Please place an order with where the product was purchased from or the office herein stated.

- **When handling the monitor, be very careful. (Applies only to products with monitors.)**

Some of the monitor parts are subject to high tension voltage. Even after turning off the power, some portions are still subject to high tension voltage sometimes. Monitor repair and replacement should be performed only by those technical personnel who have knowledge of electricity and technical expertise.

- **Be sure to adjust the monitor properly. (Applies only to products with monitors.)**

Do not operate the product leaving on-screen flickering or blurring as it is. Using the product with the monitor not properly adjusted may cause dizziness or a headache to an operator, a player, or the customers.

- **When transporting or reselling this product, be sure to attach this manual to the product.**

\* *In the case where commercially available monitors and printers are used in this product, only the contents relating to this product are explained herein. Some commercially available equipment has functions and reactions not stated in this manual. Read this manual together with the specific instruction manual of such equipment.*

\* *Descriptions herein contained may be subject to improvement changes without notice.*

\* *The contents described herein are fully prepared with due care. However, should any question arise or errors be found, please contact SEGA.*

## INSPECTIONS IMMEDIATELY AFTER TRANSPORTING THE PRODUCT TO THE LOCATION

Normally, at the time of shipment, SEGA products are in a status allowing for usage immediately after transporting to the location. Nevertheless, an irregular situation may occur during transportation. Before turning on the power, check the following points to ensure that the product has been transported in a satisfactory status.

- Are there any dented portions or defects (cuts, etc.) on the external surfaces of the cabinet?
- Are casters and adjusters damaged?
- Do the power supply voltage and frequency requirements meet with those of the location?
- Are all wiring connectors correctly and securely connected? Unless connected in the correct way, connector connections can not be made accurately. Do not insert connectors forcibly.
- Do power cables have cuts and dents?
- Are all accessories available?
- Can all doors and lids be opened with the accessory keys? Can doors and lids be firmly closed?

# INTRODUCTION

This manual is intended to provide detailed descriptions together with all necessary information covering the general operation of electronic assemblies, electro-mechanicals, servicing control, spare parts, etc. for the product, "K.O DRIVE"

This manual is intended for the owners, personnel managers in charge of operation of this product. Operate the product after carefully reading and sufficiently understanding the instructions.

In the unlikely event that the product does not function correctly, DO NOT allow anyone other than a technician to touch the internal system. Turn off the power to the machine, making sure to unplug the electrical cord from the outlet, and contact the office listed below or the point-of-purchase for this product.

Use of this product is unlikely to cause physical injuries or damage to property. However, points that require special attention are indicated by bold text, the word "IMPORTANT" and the symbol below.



Indicates important information that, if ignored, may result in the mishandling of the product and cause faulty operation or damage to the product.

## Sega Amusements Europe Limited.

42 Barwell Business Park, Leatherhead Road, Chessington, Surrey, KT9 2NY. United Kingdom.

Telephone:	+44 (0) 208 391 8090	Facsimile:	+44 (0) 208 391 8099
email:	mailbox@sega.co.uk	Web:	<a href="http://www.segaarcade.com/">http://www.segaarcade.com/</a>

## Sega Total Solutions

42 Barwell Business Park, Leatherhead Road, Chessington, Surrey, KT9 2NY. United Kingdom.

Telephone:	+44 (0) 208 391 8060	Facsimile:	+44 (0) 208 391 8096
email:	mailbox@sega.co.uk	Web:	<a href="http://www.segaarcade.com/">http://www.segaarcade.com/</a>

## Play IT

252 Beinoris Dr, Wood Dale, IL, 60191-1250 U.S.A

Telephone:	1-847-364-9787	Toll Free:	1-888-877-2669
Facsimile:	1-847-427-1065		

## SPECIFICATIONS

### Standard Cabinet (USA)

Machine Dimensions:	1,22m (48.1in.) [Width] x 1.78m (70.1in.) [Depth] max
Machine Height:	2.13m (83.9in.)
Machine Weight:	246kg (Installed)
Power, maximum current:	(AC240V - 1.20A) (AC230V - 1.25A) (AC220V - 1.30A) (AC120V - 2.25A) (AC110V - 2.45A)



## Definition of 'Site Maintenance Personnel or Other Qualified Individuals'



**Procedures not described in this manual or marked as 'to be carried out by site maintenance personnel or other qualified professionals' should not be carried out by personnel without the necessary skill or technology. Work carried out by unqualified persons may cause serious accidents, including electrocution.**

Parts replacement, maintenance inspections and troubleshooting should be carried out by site maintenance personnel or other qualified professionals. This manual includes directions for potentially dangerous procedures which should only be carried out by professionals with the appropriate specialised knowledge.

The site maintenance personnel or other qualified professionals mentioned in this manual are defined as follows:

**Site maintenance personnel:**

Individuals with experience in maintaining amusement equipment, vending machines, etc., working under the supervision of the owner/operator of this product to maintain machines within amusement facilities or similar premises by carrying out everyday procedures such as assembly, maintenance inspections, and replacement of units/expendable parts.

**Activities to be carried out by site maintenance personnel:**

Amusement equipment/vending machine assembly, maintenance inspection and replacement of units/expendable parts.

**Other qualified professionals:**

Persons employed by amusement equipment manufacturers, or involved in design, production, testing or maintenance of amusement equipment. The individual should have either graduated from technical school or hold similar qualifications in electrical/electronics/mechanical engineering.

**Activities to be carried out by other qualified professionals:**

Amusement equipment/vending machine assembly, repair/adjustment of electrical/electronic/mechanical parts.

## Waste of Electrical and Electronic Equipment (WEEE) Statement.

The WEEE (Waste of Electrical and Electronic Equipment) directive places an obligation on all EU based manufacturers and importers of Electrical and Electronic Equipment to take back products at the end of their useful life. Sega Amusements Europe Ltd accepts its responsibility to finance the cost of treatment and recovery of redundant WEEE in the United Kingdom in accordance with the specified WEEE recycling requirements.

The symbol shown below will be on all products manufactured from 13th August 2005, which indicates this product must NOT be disposed of with other normal waste. Instead, it is the user's responsibility to dispose of their waste equipment by arranging to return it to a designated UK collection point for the correct recycling of waste electrical and electronic equipment.

For more information about where you can send your waste equipment for recycling contact your local authority office.

For non-UK users contact your local authority office for information on the recycling of Waste Electrical and Electronic Equipment.

## Battery Recycling Statement.

The EC Directive on Batteries and Accumulators (2006/66/EC) aims to minimise the impact of batteries on the environment and encourage the recovery of the materials they contain. To achieve increased collection and recycling of waste batteries, the Directive places 'producer responsibility' obligations on manufacturers and importers of portable, industrial and automotive batteries.

The symbol shown below will be on all equipment fitted with batteries from 26th September 2008 and indicates they must NOT be disposed of with other normal waste. Instead, it is the user's responsibility to dispose of used batteries by arranging to return them to a designated collection point for the correct recycling.

For more information about where you can send your waste batteries for recycling contact your local authority office.



REGISTERED IN ENGLAND REGISTERED NO. 1711515

REGISTERED OFFICE: BLOCK C 42 BARWELL BUSINESS PARK, CHESSINGTON, SURREY KT9 2NY

**NOTES**

# TABLE OF CONTENTS

---

<b>INTRODUCTION</b>	<b>iii</b>
<b>1 HANDLING PRECAUTIONS</b>	<b>1</b>
<b>2 PRECAUTIONS REGARDING INSTALLATION</b>	<b>4</b>
<b>3 PRECAUTIONS REGARDING OPERATION</b>	<b>7</b>
<b>4 PART DESCRIPTIONS</b>	<b>10</b>
<b>5 ACCESSORIES</b>	<b>11</b>
<b>6 ASSEMBLY AND INSTALLATION</b>	<b>12</b>
<b>7 PRECAUTIONS WHEN MOVING THE MACHINE</b>	<b>23</b>
<b>8 GAME DESCRIPTION</b>	<b>25</b>
<b>9 EXPLANATION OF TEST AND DATA DISPLAY</b>	<b>30</b>
9-1 SWITCH UNIT AND COIN METER.	31
9-2 SYSTEM TEST MODE	32
9-3 GAME TEST MODE	33
9-4 SYSTEM INFORMATION	60
9-5 STORAGE INFORMATION	62
9-6 JVS TEST	63
9-7 MONITOR TEST	66
9-8 SPEAKER TEST	67
9-9 COIN ASSIGNMENTS	68
9-10CLOCK SETTINGS	72
9-11NETWORK TEST	74
9-12EXIT	76
<b>10 CONTROLLER UNIT(S)</b>	<b>77</b>
10-1 REMOVING THE CONTROL PANEL	78
10-2 ADJUSTING/REPLACING THE VOLUME	79
10-3 GREASING	81
10-4 START BUTTON ASSY	82
10-5 BRAKE AND ACCELERATOR UNIT	84
<b>11 GRAPHICS DISPLAY</b>	<b>88</b>
11-1 SAFETY PRECAUTIONS WHEN HANDLING THE MONITOR	88
<b>12 COIN HANDLING</b>	<b>94</b>
12-1 CLEANING THE COIN SELECTOR	94
12-2 ADJUSTING THE PRICE OF PLAY	96



<b>13</b>	<b>LAMPS AND LIGHTING</b>	<b>100</b>
	13-1 COIN DOOR LAMP	100
	13-2 LED LIGHTING - BILLBOARD	101
	13-3 FEATURE LED LOWER	103
	13-4 FEATURE LED SIDES	105
<b>14</b>	<b>PERIODIC INSPECTION</b>	<b>107</b>
<b>15</b>	<b>TROUBLESHOOTING</b>	<b>109</b>
	15-1 TROUBLESHOOTING (WHEN NO ERROR MESSAGE IS SHOWN)	109
<b>16</b>	<b>GAME BOARD</b>	<b>113</b>
<b>17</b>	<b>COMMUNICATION PLAY</b>	<b>118</b>
	17-1 INSTALLATION PRECAUTIONS	118
	17-2 CONNECTING THE COMMUNICATION CABLE	120
	17-3 NETWORK PLAY SETTINGS	121
	17-4 NETWORK PLAY PRECAUTIONS	122
<b>18</b>	<b>DESIGN RELATED PARTS</b>	<b>123</b>
<b>19</b>	<b>PARTS LIST</b>	<b>124</b>
<b>20</b>	<b>COLOUR CODE</b>	<b>146</b>
<b>21</b>	<b>SCHEMATIC DIAGRAMS</b>	<b>147</b>
<b>22</b>	<b>SERVICE AND SUPPORT</b>	<b>149</b>

# 1 HANDLING PRECAUTIONS

When installing or inspecting the machine, be very careful of the following points and pay attention to ensure that the player can enjoy the game safely.

Non-compliance with the following points or inappropriate handling running counter to the cautionary matters herein stated can cause personal injury or damage to the machine.

## WARNING

Before performing work, be sure to turn the power off. Performing the work without turning the power off can cause an electric shock or short circuit. In cases where work should be performed in the status of power on, this manual always states to that effect.

To avoid an electric shock or short circuit, do not plug in or unplug quickly.

To avoid an electric shock, do not plug in or unplug with a wet hand.

**Do not expose power cords or earth wires on the surface, (floor, passage, etc.)** If exposed, the power cords and earth wires are susceptible to damage. Damaged cords and wires can cause an electric shock or short circuit.

**To avoid causing a fire or an electric shock, do not put things on or damage the power cords.**

When or after installing the product, do not unnecessarily pull the power cord. **If damaged, the power cord can cause a fire or an electric shock.**

In case the power cord is damaged, ask for a replacement through where **the product was purchased from or the office herein stated.** Using the cord as is damaged can cause fire, an electric shock or leakage.

Be sure to perform grounding appropriately. Inappropriate grounding can cause an electric shock.

**Be sure to use fuses meeting the specified rating. Using fuses exceeding the specified rating can cause a fire or an electric shock.**

**Be sure that connections such as IC BD are made properly. Insufficient insertion can cause an electric shock.**

**Specification changes, removal of equipment, conversion and/or addition, not designated by SEGA are not permitted.**

**Failure to observe this may cause a fire or an electric shock. Non-compliance with this instruction can have a bad influence upon physical conditions of the players or the onlookers, or result in injury during play.**

SEGA shall not be held responsible for damage, compensation for damage to a third party, caused by specification changes not designated by SEGA.

Do not perform any work or change parts not listed in this manual. Doing so may lead to an accident.

If you need to perform any work not listed in this manual, request work from **the office indicated in this manual or the point of purchase, or inquires for details.**

Be sure to perform periodic maintenance inspections herein stated.

## **STOP** IMPORTANT

For the IC board circuit inspections, only the use of a logic tester is **recommended**. Using a **Multi Tester** or **General Purpose Tester** may result in damage to IC Circuits.

Static electricity from your body may damage some electronics devices on the IC board. Before handling the IC board, touch a grounded metallic surface so that the static electricity can be discharged.

This video gaming cabinet utilises a motorised steering feedback system. Do not attempt to service this part or any other part in close proximity to the steering mechanism whilst power is applied.

**Some parts are not designed and manufactured specifically for this game machine. The manufacturers may discontinue, or change the specifications of such general-purpose parts. If this is the case, SEGA cannot repair or replace a failed game machine whether or not a warranty period has expired.**

### **CONCERNING THE STICKER DISPLAY**

This SEGA product has stickers attached describing the product manufacture No. (Serial No.) and Electrical Specifications. It also has a Sticker describing where to contact for repair and for purchasing parts. When inquiring about or asking for repairs, mention the Serial No. and Name of Machine indicated on the Sticker. The Serial Number indicates the product register. Identical machines could have different parts depending on the date of production. Also, improvements and modifications might have been made after the publication of this manual. In order to ensure you order the correct parts, mention the Serial No. when contacting the applicable places.

### **CONCERNING WARNING DISPLAYS**

This SEGA product has warning displays on stickers, labels and/or printed instructions adhered/attached to or incorporated in the places where a potentially hazardous situation could arise. The warning displays are intended for accident prevention for customers and for avoiding hazardous situations relating to maintenance and servicing work. Some portions of the cabinet contain high voltage and may cause accidents if touched. When performing maintenance, be very careful of the warning displays. It is especially important that any complex repair and replacement work not mentioned herein should be performed by those technical personnel who have knowledge of electricity and technical expertise.

In order to prevent accidents, caution any customer ignoring the warnings to cease and desist immediately.



## 2 PRECAUTIONS REGARDING INSTALLATION

### WARNING

This product is an indoor game machine. Do not install it outside. Even indoors, avoid installing in places mentioned below so as not to cause a fire, electric shock, injury and/or malfunction.

Places subject to rain or water leakage, or places subject to high humidity in the proximity of an indoor swimming pool and/or shower, etc.

Places subject to direct sunlight, or places subject to high temperatures in the proximity of heating units, etc.

Places filled with inflammable gas or vicinity of highly inflammable/volatile chemicals or hazardous matter.

Dusty places.

Sloped surfaces.

Places subject to any type of violent impact.

Vicinity of anti-disaster facilities such as fire exits and fire extinguishers.

Areas where the temperature exceeds the applicable temperature (ambient temperature) range of 5 to 30 degrees centigrade.

### LIMITATIONS OF USAGE

### WARNING

Be sure to check the Electrical Specifications. Ensure that this product is compatible with the location's power supply, voltage, and frequency requirements. A plate describing Electrical Specifications is attached to the product. Non-compliance with the Electrical Specifications can cause a fire and electric shock.

This product requires a breaker and earth mechanism as part of the location facilities. Using the product without these can cause a fire and electric shock.

Ensure that the indoor wiring for the power supply is rated at 15 A or higher (AC single phase 100 V ~ 120 V area), and 7 A or higher (AC 220 V ~ 240 V area). Non-compliance with the Electrical Specifications can cause a fire and electric shock.

Be sure to use an independent power supply equipped with an earth leakage breaker. Using a power supply without an earth leakage breaker can cause an outbreak of fire if a power surge occurs.

Putting many loads on one electrical outlet can cause generation of heat and a fire resulting from overload.

When using an extension cord, ensure that the cord is rated at 15 A or higher (AC 100 V ~ 120 V area) and 7 A or higher (AC 220 V ~ 240 V area). Using a cord rated lower than the specified rating can cause a fire and electric shock.

**STOP IMPORTANT**

Securing a safe area for operation as described in this manual will ensure safe operation for players and observers.

SEGA shall not be held responsible for damage or compensation for damage to a third party, resulting from the failure to observe this instruction.

OPERATION AREA

**WARNING**

For the operation of this machine, secure a minimum area of 1.53m (W) x 2.73m (D).

Be sure to provide sufficient space specified in this manual. Do not allow objects to block the ventilation ports. It can cause generation of heat and a fire.

Sufficient space either side of the playing area must be allowed for the player to enter or exit the game safely.

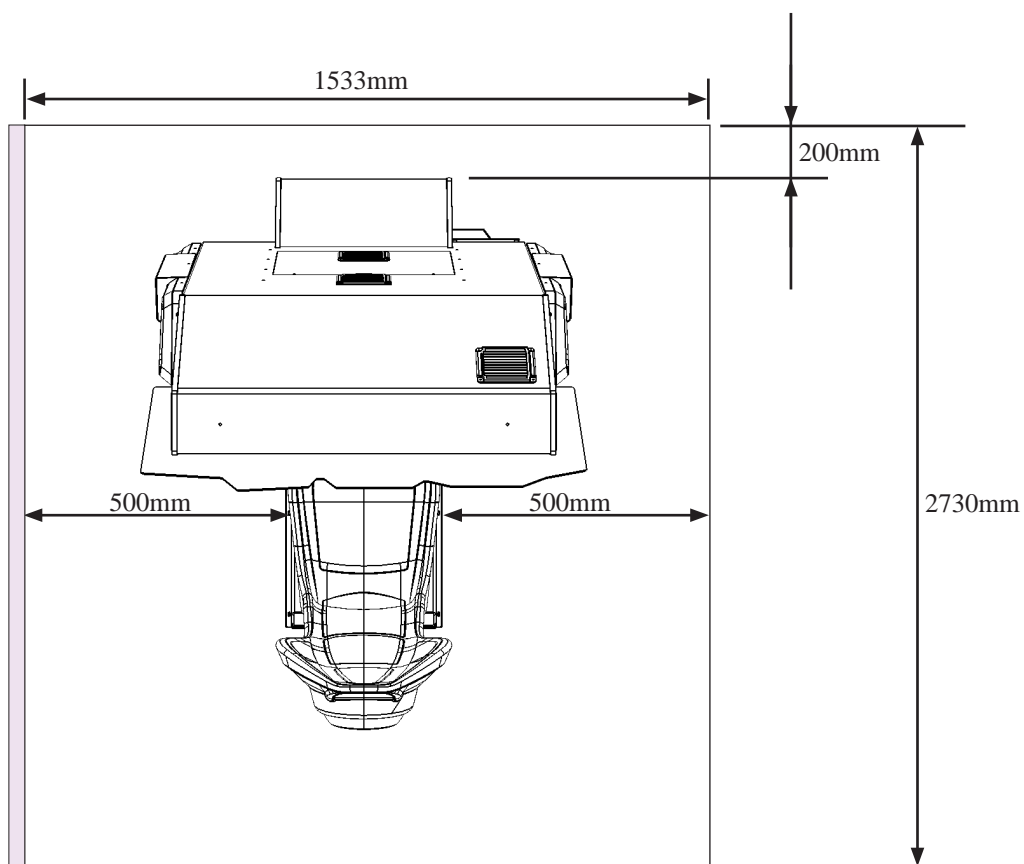



**STOP IMPORTANT**

To install this product, the entrance must be at least 1.23m in width and 2.0m in height (without Assy Billboard) and 2.14m (with Assy Billboard).

Do not attempt to push/pull whilst holding onto the Assy Billboard. This may result in part damage and or personal injury.

**2 PRECAUTIONS REGARDING INSTALLATION LOCATION**

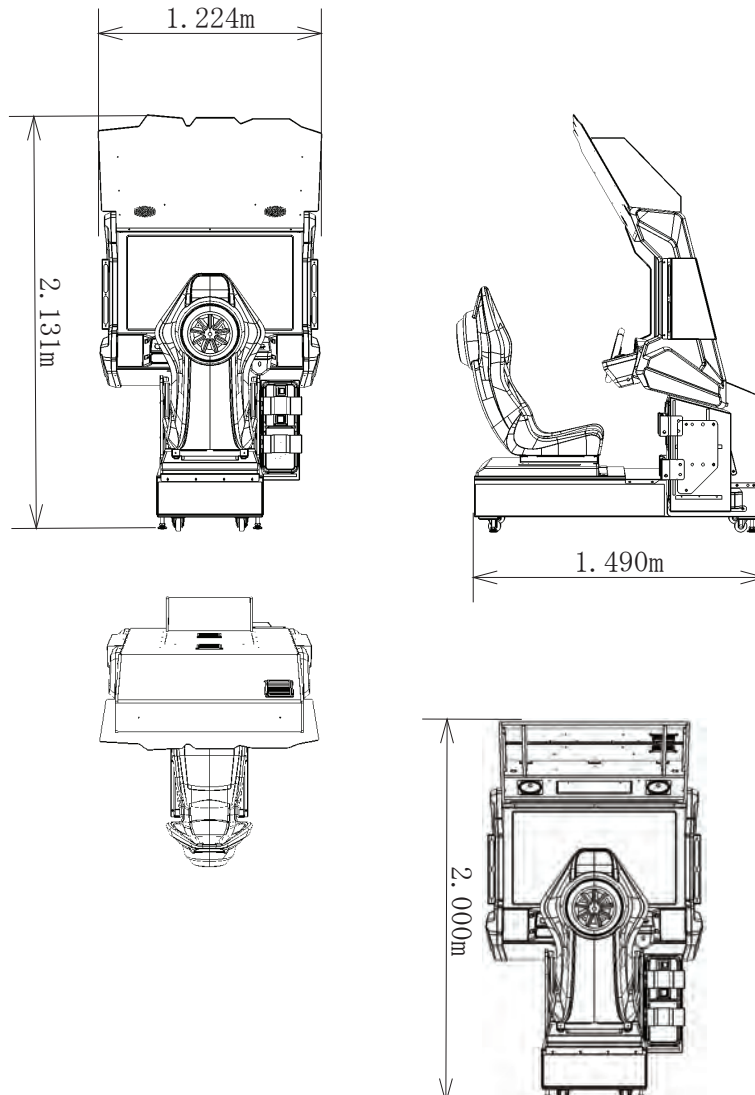

### 3 PRECAUTIONS REGARDING OPERATION

To avoid injury and trouble, be sure to pay attention to the behavior of visitors and players.

#### WARNING

In order to avoid accidents, check the following before starting the operation:

- To ensure maximum safety for the players and the customers, ensure that where the product is operated has sufficient lighting to allow any warnings to be read. Operation under insufficient lighting can cause bodily contact with each other, hitting accident, and/or trouble between customers.
- Be sure to perform appropriate adjustment of the display (LCD, Plasma, CRT or Projector). For operation of this machine, do not leave monitor's flickering or deviation as is. Failure to observe this can have a bad influence upon the players' or the customers' physical conditions.
- It is suggested to ensure a space allowing the players who feel sick while playing the game to take a rest.
- Check if all of the adjusters are in contact with the surface. If they are not, the Cabinet can move and cause an accident.

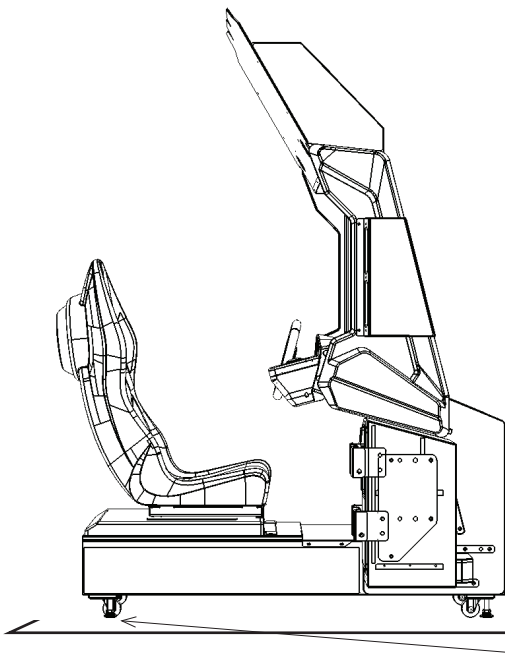

Each leg adjuster MUST be lowered so that the casters are raised approximately 5mm off the floor.

- Do not put any heavy item on this product. Items, if placed on this product may fall and cause injury to the player / observer.
- Do not climb on the product. Climbing on the product can cause falling down accidents. To check the top portion of the product, use a step ladder.

### **⚠ WARNING**

- To avoid electric shock, ensure that all covers and panels are undamaged and fitted. Do not operate with covers removed.
- To avoid electric shock, short circuit and/or parts damage, do not put the following items on or in the periphery of the product.

Flower vases, flowerpots, cups, water tanks, cosmetics, and receptacles/containers/vessels containing chemicals and water.

### **⚠ CAUTION**

- To avoid injury, be sure to provide sufficient space by considering the potentially crowded situation at the installation location. Insufficient installation space can cause making bodily contact with each other, hitting accidents, and/or trouble between customers.
- Everyday when cleaning the Controller, inspect the controller and make sure that there are no cracks in the surface, and that the fastening screws are not loose. If the game is played with cracks or loose screws, it can cause injuries to the player.
- Do not allow more than one person in any seat at any time. Do not allow adults to play the game with a child sitting in their lap.

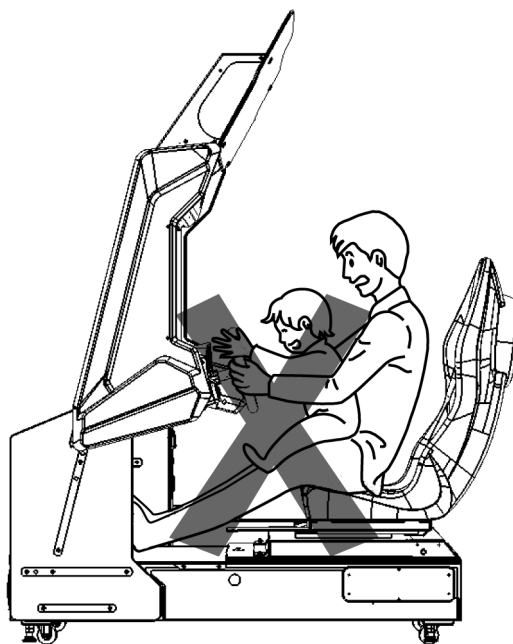

### **⚠ WARNING**

It is recommended that wet towels (paper towels) be provided.

## DURING OPERATION (PAYING ATTENTION TO CUSTOMERS)

To avoid injury and trouble, be sure to constantly give careful attention to the behavior and manner of the visitors and players.

### WARNING

- **For safety reasons, do not allow any of the following people to play the game.**
- Those who have high blood pressure or a heart problem.
- Those who have experienced muscle convulsion or loss of consciousness when playing video games, etc.
- Those who have neck or spinal cord problems.
- Those who are intoxicated or under the influence of drugs.
- Pregnant women.
- Those who are not in good health.
- Those who do not follow the attendant's instructions.
- Those who cannot grasp the Control Unit securely because of immobility in fingers, hands or arms.
- Persons who disregard the product's warning displays.

This product is intended for a single player only. Having two or more persons simultaneously playing this product can result to injury to the player and possible damage to the product.

- **Even players who have never been adversely affected by light stimulus might experience dizziness or headache depending on their physical condition when playing the game.**

Small children are especially likely to experience these symptoms. Caution guardians of small children to keep watch on their children during play.

- **Instruct those who feel sick during play to have a medical examination.**
- **To avoid injury from falls and electric shocks due to spilled drinks, instruct the player not to place heavy items or drinks on the product.**
- **To avoid electric shocks and short circuits, do not allow customers to put hands and fingers or extraneous matter in the openings of the product or small openings in or around the doors.**
- **To avoid falls and resulting injury, immediately stop the customer from leaning against or climbing on the product, etc.**
- **To avoid electric shock and short circuit, do not allow customers to unplug the power plug without a justifiable reason.**
- **Instruct the guardians of small children to keep an eye on their children.**

Children cannot sense danger. Allowing small children to get near a player who is playing the game could result in the children being bumped, struck or knocked down.

# 4 PART DESCRIPTIONS

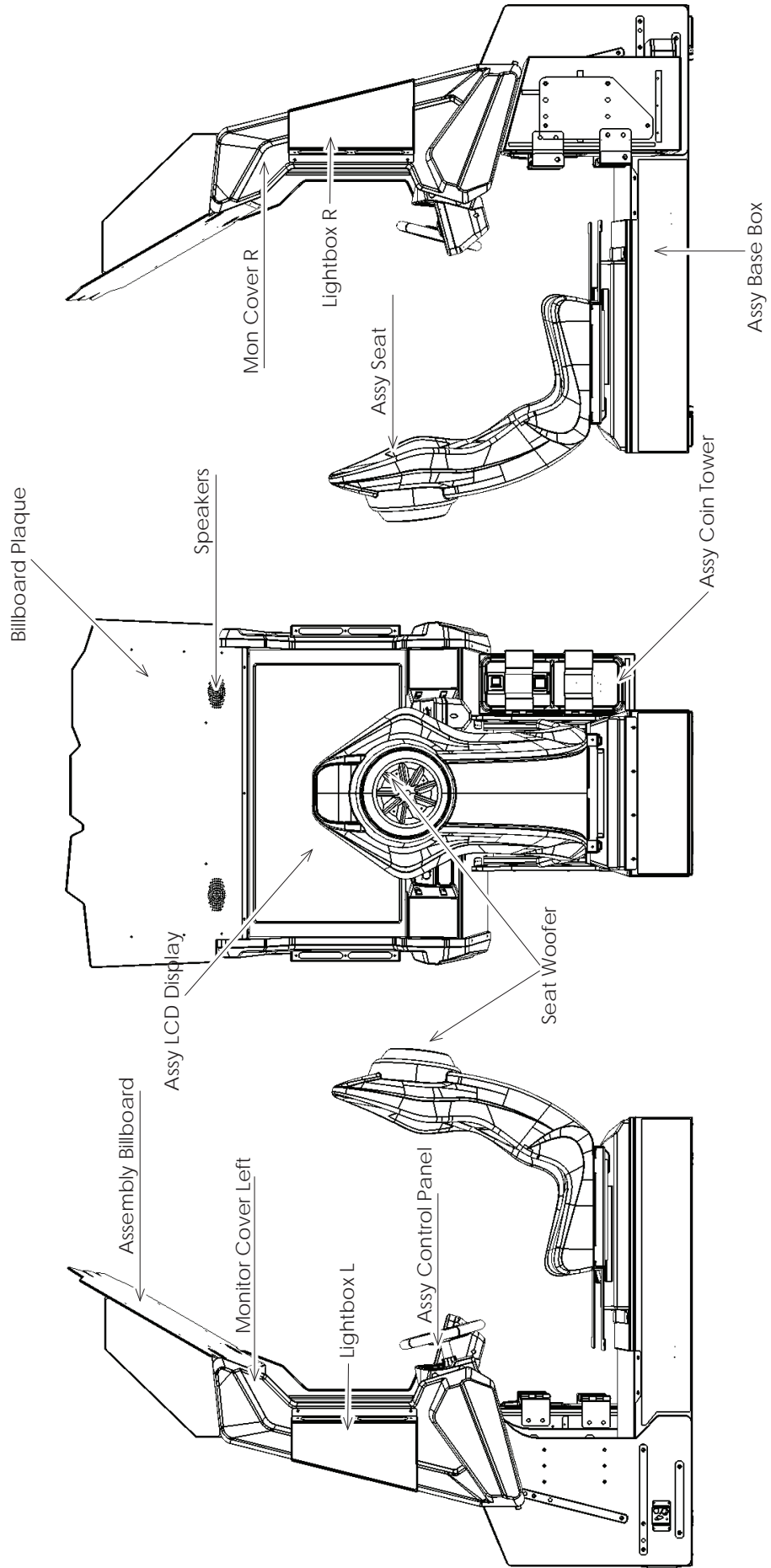

# 5 ACCESSORIES

Confirm that the accessories listed in the table below are present when setting up the product. Accessories marked "Spare" in the note column are consumable items but included as spares.

Parts not labeled with part numbers are as yet unregistered or cannot be registered. Be sure to handle all parts with care, as some parts are not available for purchase separately.

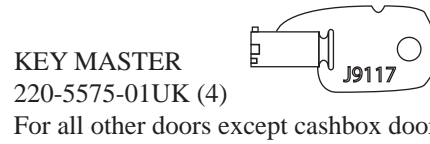
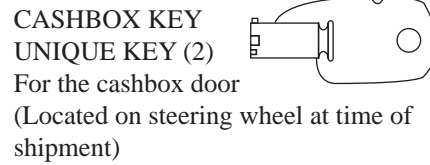
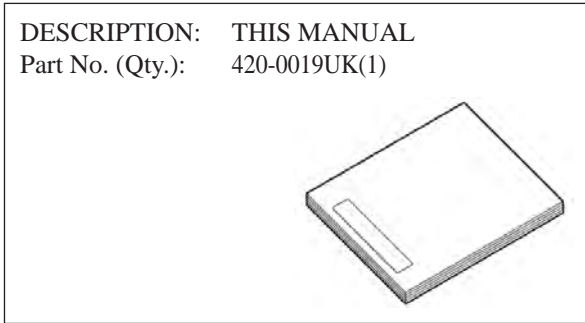

LABEL AAMA ALL AGES  
LB1170 (1)



SPEAKER PANEL  
PD-1356UK (1) - fixed to:

BRACKET SPKR PANEL LWR  
PD-1355UK (1)

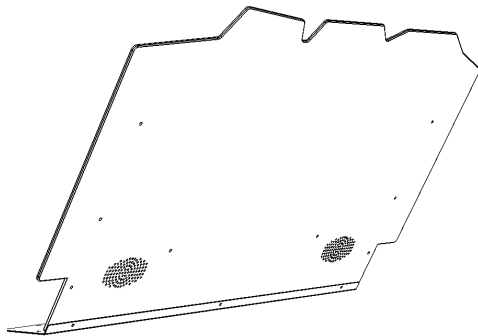

Epilepsy Labels (Multilingual)  
440-CS0186-01UK

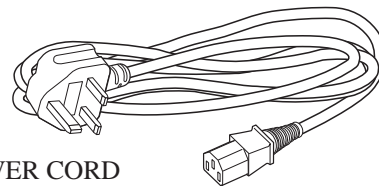

POWER CORD  
LM1227 (1) <UK>  
LM1226 (1) <EU>  
LM1500 (1) <US>  
For installation. See chapter 6.

FIXINGS (in self seal bag)

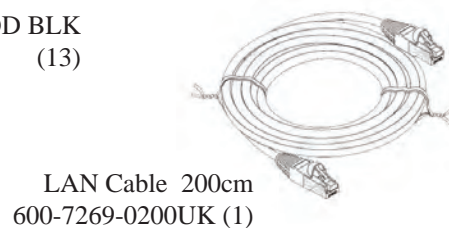
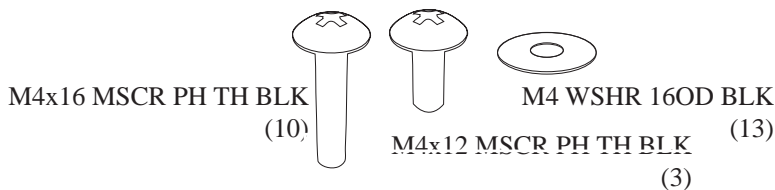



## 6 ASSEMBLY AND INSTALLATION

### WARNING

- Perform assembly work by following the procedure herein stated. Failure to comply with the instructions can cause electric shock.
- Perform assembly as per this manual. Since this is a complex machine, **incorrect assembling can cause an electric shock, machine damage and/or improper functioning as per specified performance.**
- When assembling, more than one person is required. Depending on the assembly work, there are some cases in which working by one person alone can cause personal injury or parts damage.
- Ensure that connectors are properly connected. Improper connections can cause electric shock.
- Be careful not to damage the wires. Damaged wires may cause electric shock or short circuit or present a risk of fire.
- Do not unnecessarily push the display screen.
- This work should be carried out by site maintenance personnel or other **qualified professionals. Work performed by non-technical personnel can cause a severe accident such as electric shock. Failing to comply with this instruction can cause a severe accident such as electric shock to the player during operation. If no one with proper technological expertise is available, request service from the office indicated in this document or the point of purchase so as to ensure safety.**
- **Provide sufficient space so that assembling can be performed. Performing work in places with narrow space or low ceiling may cause an accident and assembly work to be difficult.**
- To perform work safely and avoid serious accident such as the cabinet falling down, **do not perform work in places where step-like grade differences, a ditch, or slope exist.**
- This product does not use any connectors other than those connected to and used by the game board when it leaves the factory. Do not needlessly connect wires to unused connectors. This could lead to overheating, generation of smoke and burn related injuries.

### CAUTION

- Handle molded parts with care. Excessive weight or pressure may cause them to break and the broken pieces may cause injury.
- To perform the operation safely and accurately you must use a safe, steady footstool or stepladder. Working without this may lead to a fall and possible injury.

## 6-1 INSTALLING THE CABINET

### CAUTION

- Billboard weighs approximately 10kg. Have at least 2 people during this operation. Working alone could result in personal injuries, etc.
- To perform work safely and securely, be sure to prepare a step which is in a safe and stable condition. Performing work without using a step may lead to injury of damage to components.

Tools required for installation



PHILLIPS No1 Screwdriver  
- Attaching Billboard Panel

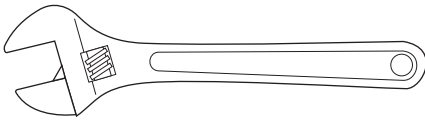

Adjustable Wrench  
- Secure cabinet into position.

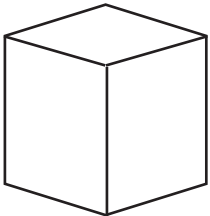

Step or Ladders  
- Aid in fixing Billboard and Billboard Panel.

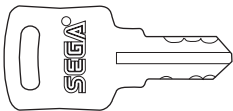

KEY  
- Gain access to Coin Tower

## 6-1-1 INSTALLING THE BILLBOARD PLATE & BKT

- 1 Locate and remove the 6 sets of fixings from the Billboard Plate fixing points within the Billboard Housing.

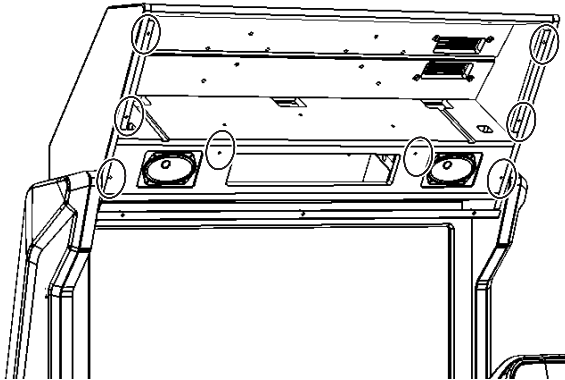

Remove fixings before fitting the Billboard Plate.

- 2 Using two people and a stepladder. Offer the Billboard Plate up to the Assy Billboard.

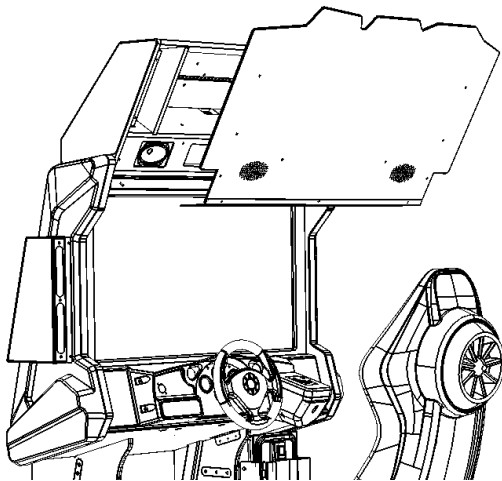

- 3 Fix the Billboard Plate into position using the fixings removed in step 1. Do not tighten fixings at this stage.

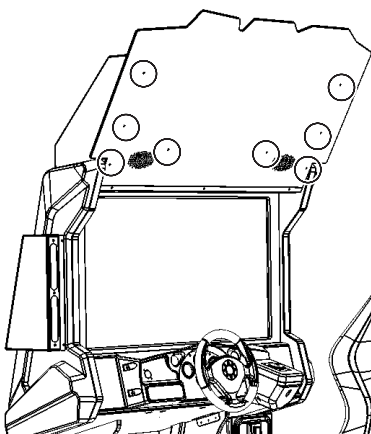

---

**4** Apply the M4x12 MSCR TH BLK (3) and M\$ WSHR 16OD BLK (3) to the BILLBOARD BRKT.

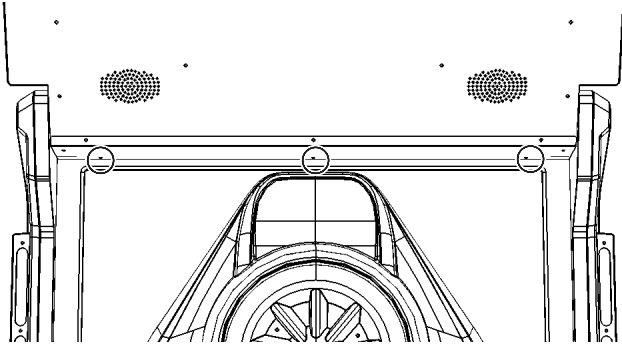

---

**5** Apply the M4x16 MSCR TH BLK (2) and M\$ WSHR 16OD BLK (2) to the BILLBOARD BRKT.

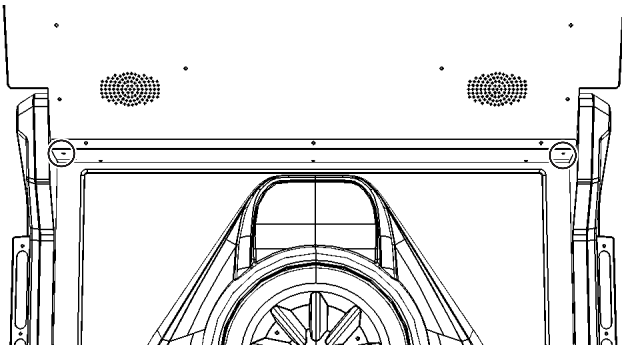

---

**6** Once inplace - tighten all fixings.

**6-2 FIXATION TO INSTALLATION SITE**

**⚠ WARNING**

- Make sure that all the adjusters contact the floor. Otherwise the cabinet could move, causing an accident.
- Provide a ventilation space at least 20cm wide behind the cabinet. There are ventilation holes on the back of the cabinet. Do not block the ventilation holes. Doing so could trap heat inside resulting in fire. It could also result in equipment damage or cause parts to become exhausted prematurely.

The product is equipped with 4 casters and 4 adjusters.

When installation position / site has been determined, have the adjusters come in direct contact with the floor. Establish a gap of about 5 mm between the floor and the casters and adjust the unit so that it will remain level.

1 Move the product to the installation site.

2 Bring the adjusters into direct contact with the floor. Use a wrench to align the height of the adjusters until the cabinet is perfectly level.

3 After setting, turn adjuster nuts upwards to tighten them and secure adjuster heights.

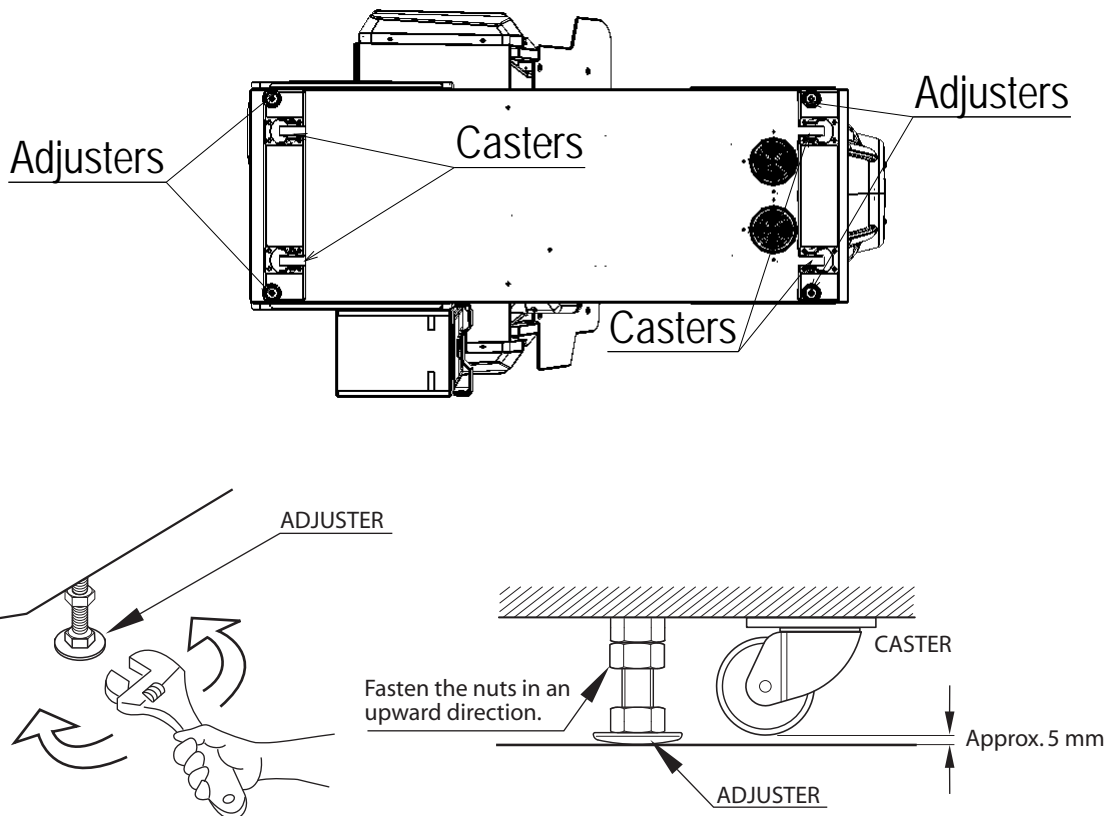

**⚠ WARNING**

- Provide a ventilation space at least 15cm wide behind the cabinet. There are ventilation holes on the back of the cabinet. Do not block the ventilation holes. Doing so could trap heat inside resulting in fire. It could also result in equipment damage or cause parts to become exhausted prematurely.

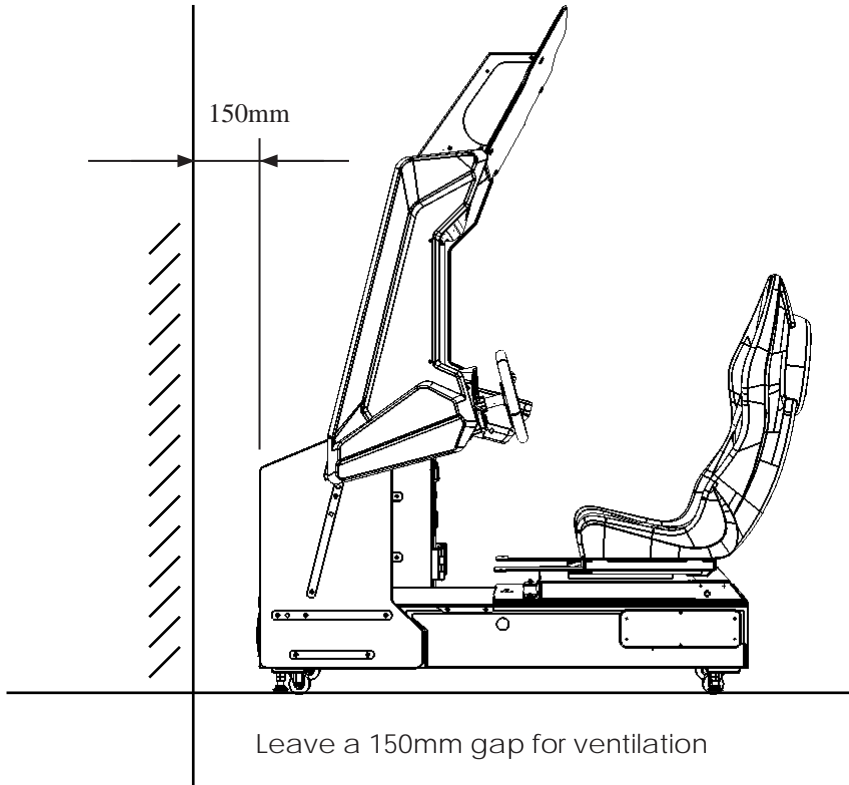



**6-3 POWER SUPPLY, AND GROUND CONNECTION**

**⚠ WARNING**

- Use the power supply equipped with an earth leakage breaker. Use of power supply without such a breaker could result in fire if there is a current leakage.
- Have available a securely grounded indoor ground terminal. Without proper grounding, customers could be electrocuted and product operations might not always be stable.
- Do not expose the power cord or ground wire. If these are exposed, customers could stumble over them, for instance, and easily damage them. Additionally, if these lines are damaged, there could be a risk of electrical shock or short circuit. Set these lines at locations where they will not interfere with customer traffic, or attach covers to them.
- After laying out the power cord on the floor, be sure to always protect it. If the power cord is left exposed, it can easily be damaged, resulting in electrical shock.

**1** Confirm that the main switch is at OFF.

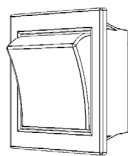
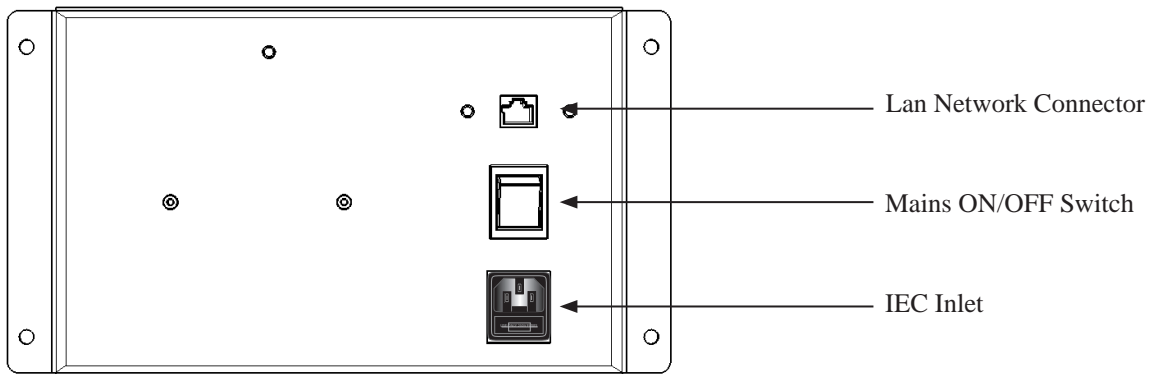

Mains Switch shown in OFF position

---

**2** Fully insert the power cord connector on the side opposite the power plug into the AC unit IEC inlet. Insert the power cord plug into the outlet.

---

**3** When the power cord is laid out indoors. Protect the power cord by attaching a wire cover to it. If the power cord is left uncovered it may cause a trip hazard and could result in injury. Please cover the power cord as illustrated below.

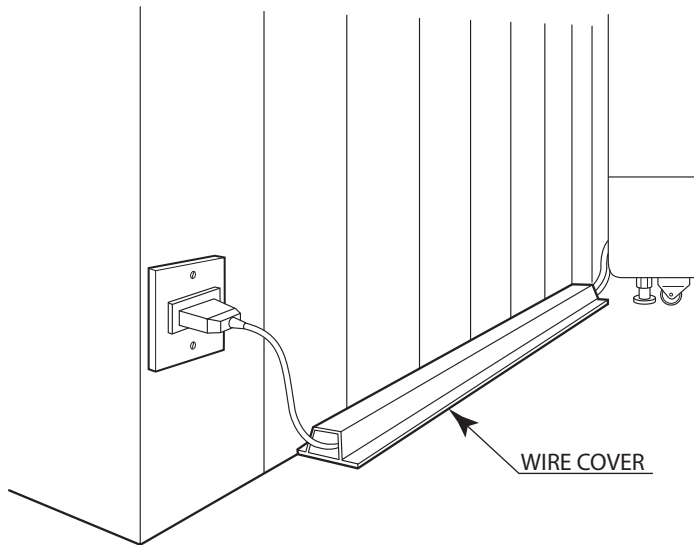

## 6-4 TURN ON POWER

Set the main switch of the AC unit to ON and engage the power.

When you turn on the power, the billboard LED lights will come on.

The Steering wheel will SET-UP.

After the SEGA LOGO start up screen is displayed on the LCD screen, the Advertise (Attract) Mode will start.

The decorative LEDs on the LEFT and RIGHT outer PODS will flash on/off.

Start up sounds are output from the speakers on the left and right of the cabinet together with display of the SEGA startup screen.

Even when the power source has been cut off, credit count, ranking data, game settings and bookkeeping data are kept stored in the product. However, fractional coin counts (inserted coins that do not amount to one credit) and bonus adder counts are not kept.

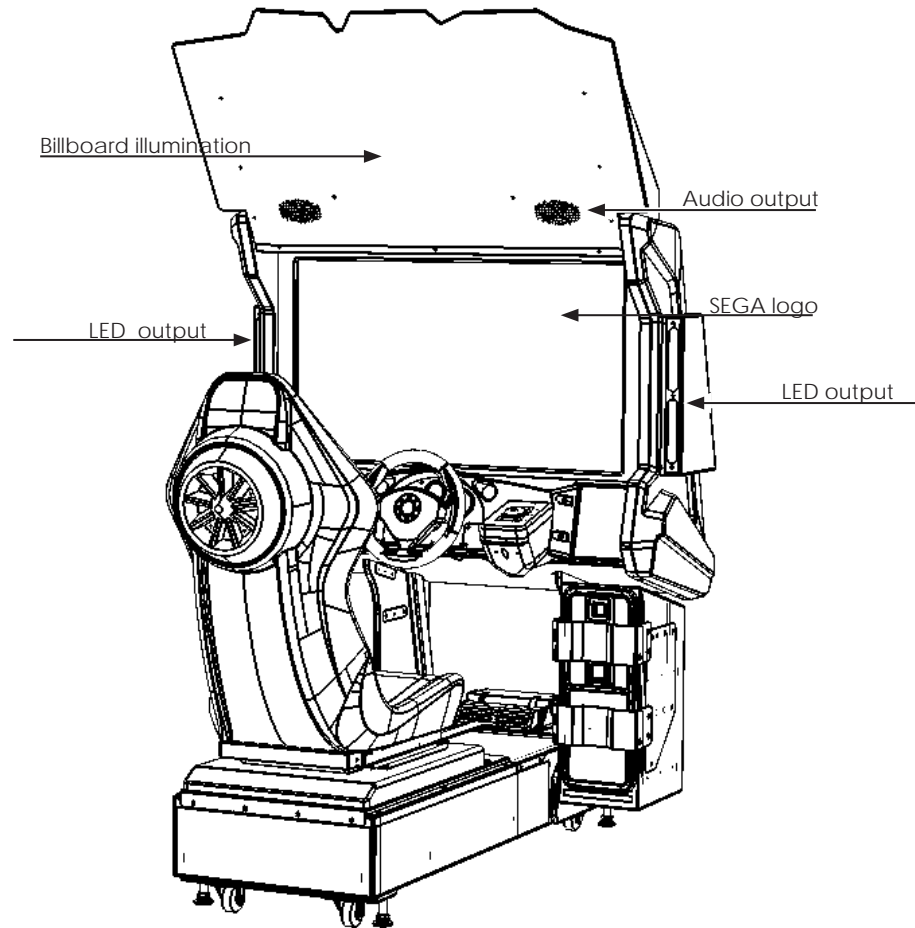

## 6-5 CONFIRMATION OF ASSEMBLY

In the test mode, ascertain that the assembly has been made correctly and IC Board is satisfactory.  
In the test mode, perform the following test: (refer to chapter 9).

### 9-3-3 INPUT TEST

This menu is used to test the system inputs such as steering, pedals and buttons. To implement the test, press each device that is listed and check the results on screen.

### 9-3-4 OUTPUT TEST

This menu is used to test the system outputs such as Lamps and LED.

### 9-3-8 NETWORK TEST

Apply and configure the network of each cabinet (only applies if 2 or more cabinets are linked).

### 9-3-10 CALIBRATION TEST

This test is required to calibrated both steering mechanism and control pedals. This procedure is always carried out at the factory before dispatch. However, certain conditions can have an effect on calibration and it is recommended that re-calibration be carried out at point of installtion.

**6-6 APPLYING WARNING LABELS (EPILEPTIFORM SEIZURES)**

**⚠ CAUTION**

- The operator **MUST** apply the Epileptiform Seizure Label to this product. Failing to apply this label may result in the player/observer suffering from a photosensitive seizure. Warning the potential player/ observer of this before the start of a game may prevent such accidents.
- It is also important to apply the correct language label for each location. There are nine (9) different language labels - please apply the label which matches your location.

**STOP IMPORTANT**

Application of any warning labels must be placed in a location which is easy for the player/observer to read. Please follow the instructions below and apply the label in the location stated.

The Epileptiform Seizure label is supplied in 9 different languages. Please choose the label which matches your language location.

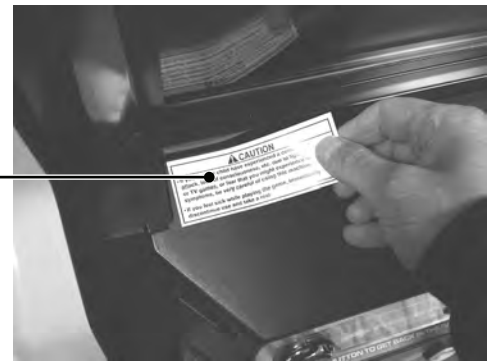

Apply the label to the top left hand corner of the Control Panel. This location is unobstructed and can be easily read by players and observers alike.



## **7** PRECAUTIONS WHEN MOVING THE MACHINE

### **WARNING**

- Always disconnect the power cable before moving the product. If it is moved with the power cable connected, the cable could be damaged, causing fire or electric shock.
- To move the unit over the floor, pull in the adjusters and have the casters contact the floor. While moving the unit, be careful that the casters do not roll over the power cord or the ground wire. If cord or wire is damaged, there could be electrical shocks and/or short circuits.
- When crossing a sloped or stepped area, always have the machine travel lengthways. Travelling with the machine in a sideways position could result in the machine falling over onto its side. Always use a minimum of two people working together plus lifting apparatus to accommodate sloped areas or stairs.
- To lift up the cabinet, hold it at the bottom at the designated lifting points. If you hold it anywhere else, the weight of the cabinet could cause damage to parts or attachments, resulting in injury.
- Do not push the cabinet from the side when moving. Pushing from the side as it may result in the cabinet falling over.

### **IMPORTANT**

- When moving the cabinet, do not grip or push the Billboard Plate. Doing so could deform or damage the part.
- If moving through a door or place with a low ceiling such as an elevator, you should take apart the billboard and billboard plate.

## 7-1 PRECAUTIONS WHEN MOVING (US STD)

### **STOP** IMPORTANT

- When moving the cabinet, do not grip or push the Billboard Plate. Doing so could deform or damage the part.
- If moving through a door or place with a low ceiling such as an elevator, you should take remove the billboard plate.

Detailed instructions for removing the Assy Billboard and Billboard Plate can be found in Chapter 6 of this manual. Please follow these instruction in reverse order for removal.

Ensure that the casters come into contact with the floor before moving.

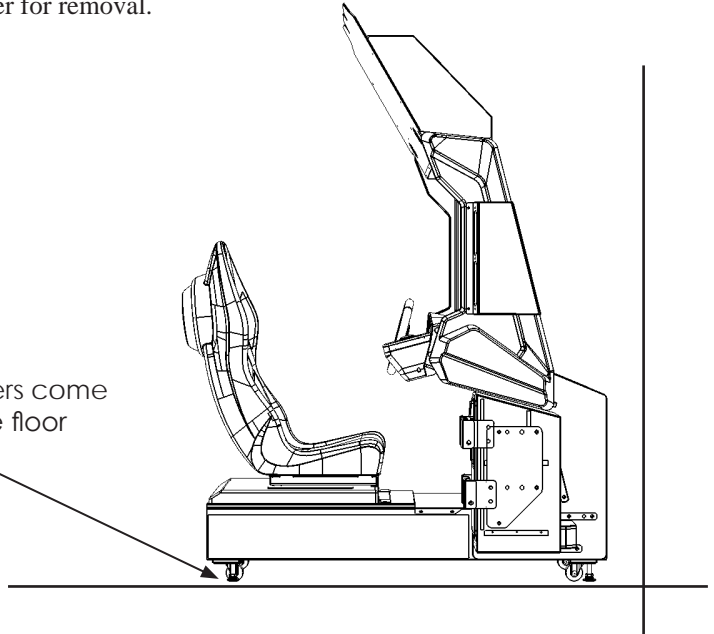

Remove the Billboard Plate when transporting the machine in and out of buildings or when passing through areas with low ceilings.

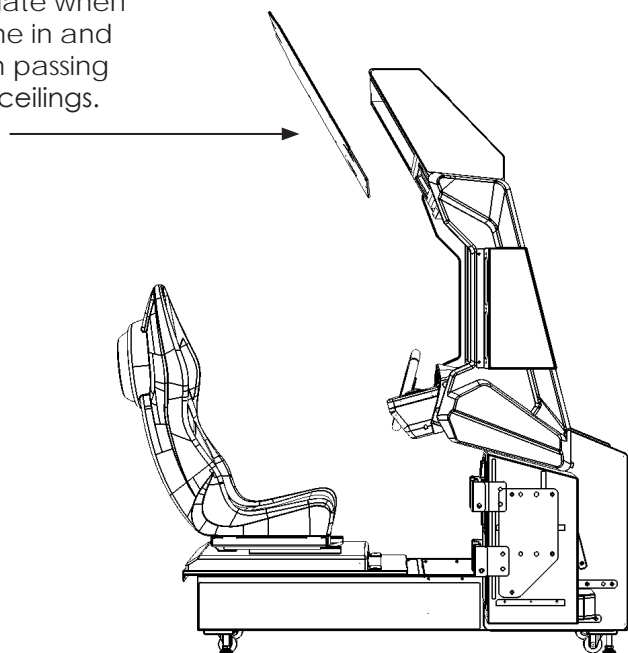

## 8 GAME DESCRIPTION

This title is a car racing game, mainly featured with multiplayer competition . It supports up to 6 cabinets to play at the same time.

Ignite the engine and launch a high speed racing competition with attack and being attacked iterations. The last place racer still has the opportunity to overturn the ranking and win the race.

### BASIC CONTROLS

Accelerator	Accelerate the car speed.
Brake	Decrease the car speed.
Start/Weapon button	Press the weapon button in the race to trigger the attack action.
Steering wheel	Control the direction of the car.

### ADVANCED CONTROLS

Drift	Turn the steering wheel to one end to perform excellent drift action.
Super drift	Press the brake pedal and release it immediately during the drift to perform much faster super drift action.

## 8-1 THE GAME

Insert the coins to meet the game requirement.

The Start/Weapon button light will blink when the required numbers of coins are inserted.



Select the scene. Turn the wheel to select the scene, press the Start/Weapon button to confirm the selection.





Select the course. Turn the wheel to select the course, press Start/Weapon button to confirm the selection.



Scenes in total, and each scene contains 4 courses.

STAGE	LAPS IN DEFAULT	UNLOCK CONDITION IN DEFAULT
CANADA 1	4	Unlocked in the beginning
CANADA 2	4	Unlocked in the beginning
CANADA 3	4	Unlocked after stage 1 or 2 is completed
CANADA 4	4	Unlocked after stage 3 is completed
EGYPT 1	4	Unlocked in the beginning
EGYPT 2	4	Unlocked in the beginning
EGYPT 3	4	Unlocked after stage 1 or 2 is completed
EGYPT 4	4	Unlocked after stage 3 is completed
LAS VEGAS 1	3	Unlocked in the beginning
LAS VEGAS 2	2	Unlocked in the beginning
LAS VEGAS 3	3	Unlocked after stage 1 or 2 is completed
LAS VEGAS 4	2	Unlocked after stage 3 is completed
SHANGHAI 1	4	Unlocked in the beginning
SHANGHAI 2	2	Unlocked in the beginning
SHANGHAI 3	4	Unlocked after stage 1 or 2 is completed
SHANGHAI 4	2	Unlocked after stage 3 is completed
LONDON 1	3	Unlocked in the beginning
LONDON 2	2	Unlocked in the beginning
LONDON 3	3	Unlocked after stage 1 or 2 is completed
LONDON 4	2	Unlocked after stage 3 is completed

## MULTIPLAY

When the multi-play mode is launched, the first selected course by player will be entered.

## GAME FEATURES

In weapon upgrade screen, the player is allowed to use the KO props obtained in the game to upgrade the weapon.

The player is also allowed to insert coins and press the brake pedal to purchase KO props in weapon upgrade screen. 1 continue point = 50 scores.



Select your favorite car type. Turn the steering wheel to select car type and press Start/Weapon button to confirm.



12 car types in total and each type is featured for diverse car speed, turning ability, accelerate ability and weight.

8 cars in maximum are allowed to compete at the same time on the course arena. The players have to complete the game by hitting the finishing line under required time.

Extra time will be rewarded each time the player completes 1 lap of the course.

## 8-2 GAMEPLAY SCREEN

### RACE SCREEN



### WEAPON SYSTEM

The player will obtain corresponding color represented weapon by random when their car passes through the weapon panel on the course.

red	attack	Machine gun, tracking missile, etc
yellow	defense	Energy shield, radar defense jet, etc
green	trap	500lb bomb, road blocker smash, etc
blue	speed	Power saw, smash drill, etc.

Every weapon in weapon upgrade screen can upgrade by KO props. Each weapon has 5 types. Each car has 20 types of weapons which makes 60 types of weapons in total in the game.





When the race is over, a summary screen will be displayed (score screen).

The player will enter weapon upgrade screen to upgrade the weapon by KO props.

The player will then enter continue screen, insert the required coins and press

Start/Weapon button to go back to weapon upgrade screen to continue the game.

the weapon level will be kept and the player will be rewarded certain KO props after continue game.

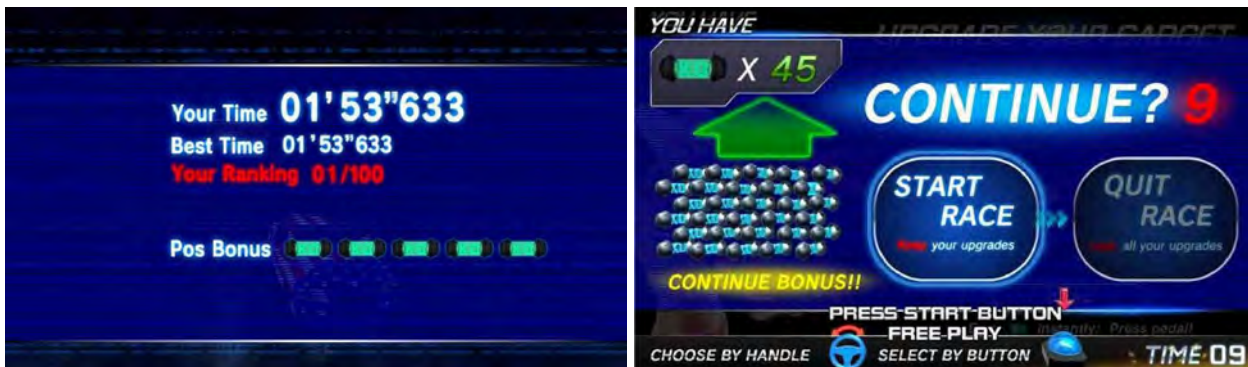

If the player does not continue play or the counting down number goes back to 0, the game is over.





## 9 EXPLANATION OF TEST AND DATA DISPLAY

Perform tests and data checks periodically by manipulating the TEST Button and SERVICE Button in the cabinet. Follow the instructions in this chapter to conduct checks when the game machine is first installed, when money is being collected, or when the game machine does not operate properly.

Shown overleaf are the tests and screens to be used for different problems.

### WARNING

- When installing 2 of more cabinets which are networked together. The **GAME SETTINGS** which are adjusted within the first cabinet are reflected throughout all cabinets within that network.

### IMPORTANT

- When changing the game configuration within the **TEST MODE**, be sure to exit all screens in the correct manner by choosing exit. **DO NOT** turn the machine **ON/OFF** to resume game. Changes **WILL NOT** take effect unless the correct method is used.

## 9-1 SWITCH UNIT AND COIN METER.

### **⚠ WARNING**

Never touch places other than those specified. Touching places not specified can cause electric shock and short circuit accidents.

### **STOP IMPORTANT**

- Adjust the sound to the optimum volume, taking into consideration the environmental requirements of the installation location.
- Removing the Coin Meter circuitry renders the game inoperable.

#### 9-1-1 SWITCH UNIT

Open the coin chute door, and the switch unit shown will appear.  
The functioning of each SW is as follows:

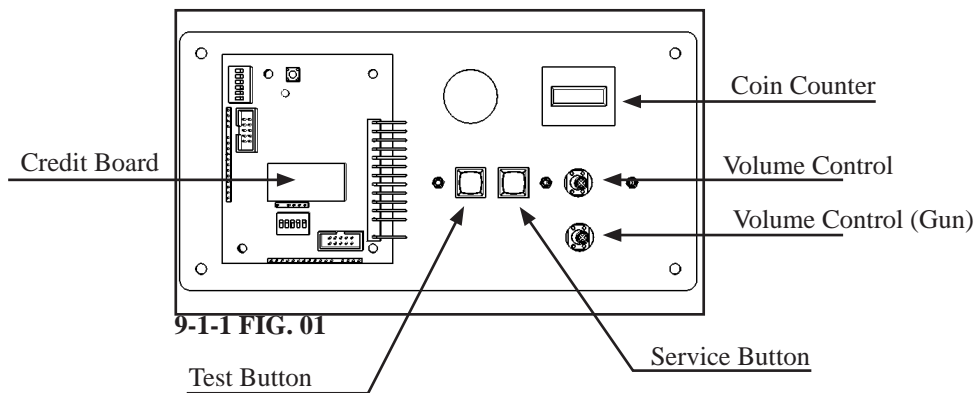

9-1-1 FIG. 01

TEST Button (TEST):	For the handling of the Test Button, refer to the following pages.
SERVICE Button (SERVICE):	Gives credits without registering on the coin meter.
Sound Volume Switch (SOUND VOLUME):	Adjust sound volume for all of the machines' speakers.
Coin Counter	Counts and displays coins in \$0.10 units.
Credit Board	Counts coins to be used a price of play

## 9-2 SYSTEM TEST MODE

### STOP IMPORTANT

The details of changes to Test Mode settings are saved when you exit from each Test Mode by selecting EXIT. Be careful because if the power is turned off before that point, changes to the settings will be lost.

SYSTEM TEST MODE can be used to check the information or the operation of RINGWIDE, adjust Monitor color, and perform coin/credit settings.

1 Press the TEST Button after powering on the unit to display the following SYSTEM TEST MODE.

#### ■ SYSTEM TEST MODE Screen

SYSTEM TEST MODE	
GAME TEST MODE .....	9-3
SYSTEM INFORMATION .....	9-4
STORAGE INFORMATION .....	9-5
JVS TEST .....	9-6
MONITOR TEST .....	9-7
SPEAKER TEST .....	9-8
COIN ASSIGNMENTS .....	9-9
CLOCK SETTING .....	9-10
NETWORK SETTING .....	9-11
-> EXIT .....	9-12
SELECT WITH SERVICE BUTTON AND PRESS TEST BUTTON	

2 Use the SERVICE Button to move the cursor to the desired test item.

3 Press the TEST Button to enter the selected item's test.

4 After the test is complete, move the cursor to EXIT and press the TEST Button to return to the game play screen.

For a detailed explanation on the SYSTEM TEST MENU, please refer to chapter 16 - Game Board.

## 9-3 GAME TEST MODE

### STOP IMPORTANT

- To change settings in the **GAME TEST MODE**, simply making changes on the setting screen will not be effective. Complete the **TEST MODE** in normal fashion.
- Use with the specified settings. If settings other than those specified are used, inappropriate operations or malfunction may occur.

Press the **TEST** Button to enter **TEST MODE** and bring up the **SYSTEM TEST MENU** screen. (See Chapter 9.) **SERVICE** Button to select “**GAME TEST MODE**,” then press the **TEST** Button to bring up the **GAME TEST MENU** screen.

### 9-3-1 GAME TEST MENU

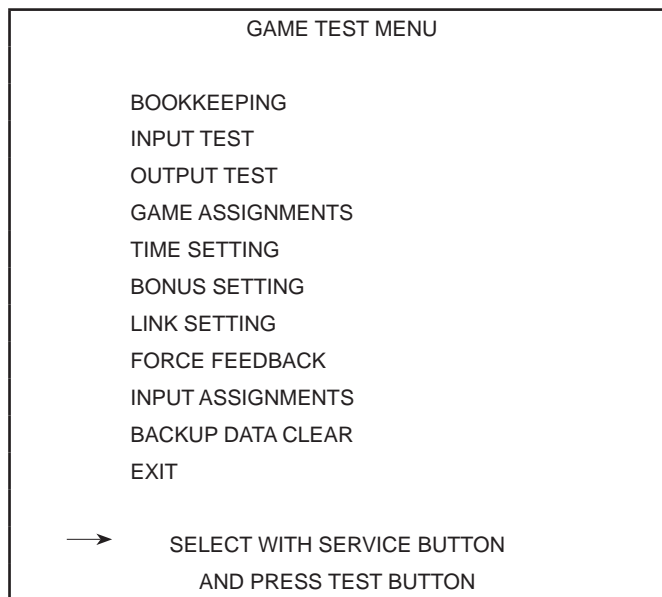

### GAME TEST MENU

#### ■ Controls

- Press the **SERVICE** Button to select menu item.
- Press the **TEST** Button to confirm the selected item.
- Selecting **EXIT** and pressing the **TEST** Button, the **SYSTEM TEST MENU** screen reappears.

#### ■ Menu Items

<b>BOOKKEEPING</b>	Displays all recorded game data.
<b>INPUT TEST</b>	Test each input device used for game.
<b>OUTPUT TEST</b>	Test each output device used for game.
<b>GAME ASSIGNMENTS</b>	Adjust all game settings.
<b>TIME SETTING</b>	Adjust selection screen time settings
<b>BONUS SETTING</b>	Configure Bonus type and settings
<b>LINK SETTING</b>	Adjust linking settings for multiplayer mode
<b>FORCE FEEDBACK</b>	Adjust controller feedback strength
<b>INPUT ADJUSTMENTS</b>	Configure Input devices - steering and pedals
<b>BACKUP DATA CLEAR</b>	Erases all types of game records.



## 9-3-2 BOOKKEEPING

Each game record can be viewed

BOOKKEEPING 1/12	
COIN CHUTE #1	*
COIN CHUTE #2	*
TOTAL COINS	*
COIN CREDITS	*
SERVICE CREDITS	*
TOTAL CREDITS	*
PRESS TEST BUTTON TO CONTINUE	

BOOKKEEPING SCREEN 1/12

<b>COIN CHUTE #1</b>	Number of coins inserted in coin chute 1.
<b>COIN CHUTE #2</b>	Number of coins inserted in coin chute 2.
<b>TOTAL COINS</b>	Total Number of coins inserted in coin chute 1 and 2.
<b>COIN CREDITS</b>	Number of credits for coins inserted.
<b>SERVICE CREDITS</b>	Number of credits entered with the SERVICE Button.
<b>TOTAL CREDITS</b>	Total number of all credits.

This test is used to review statistical data from the system. It consists of 3 screens of data. Page 1 displays an overview of the coins and credits data.

Press the Test Button to go to Page 2.

BOOKKEEPING 2/12	
NUMBER OF GAMES	*
SINGLE PLAY	*
FIRST PLAY	*
CONTINUE PLAY	*
MULTIPLAY	*
FIRST PLAY	*
CONTINUE PLAY	*
BUT K.O COUNTS	*
NUMBER OF BONUS GAMES	*
TOTAL TIME	*D **H **M **S
PLAY TIME	*D **H **M **S
AVERAGE PLAY TIME	**M **S
LONGEST PLAY TIME	**M **S
SHORTEST PLAY TIME	**M **S
PRESS TEST BUTTON TO CONTINUE	

BOOKKEEPING SCREEN 2/12

<b>NUMBER OF GAMES</b>	Total number of games played
<b>SINGLE PLAY</b>	Total number of games played from the start for 1P
<b>MULTIPLAY</b>	Total number of games played in multiplayer mode
<b>FIRST PLAY</b>	Total number of first played games
<b>CONTINUE PLAY</b>	Total number of continues for 1P
<b>BUY K.O COUNTS</b>	Total number of K.O item
<b>TOTAL TIME</b>	The cabinet's total operating time.
<b>PLAY TIME</b>	Amount of time game has been played.
<b>AVERAGE PLAY TIME</b>	Average play time for one game.
<b>LONGEST PLAY TIME</b>	Longest play time for one game.
<b>SHORTEST PLAY TIME</b>	Shortest play time for one game.

Press the Test Button to go to Page 3.

Bookkeeping – Page 3 – Data on Car selections

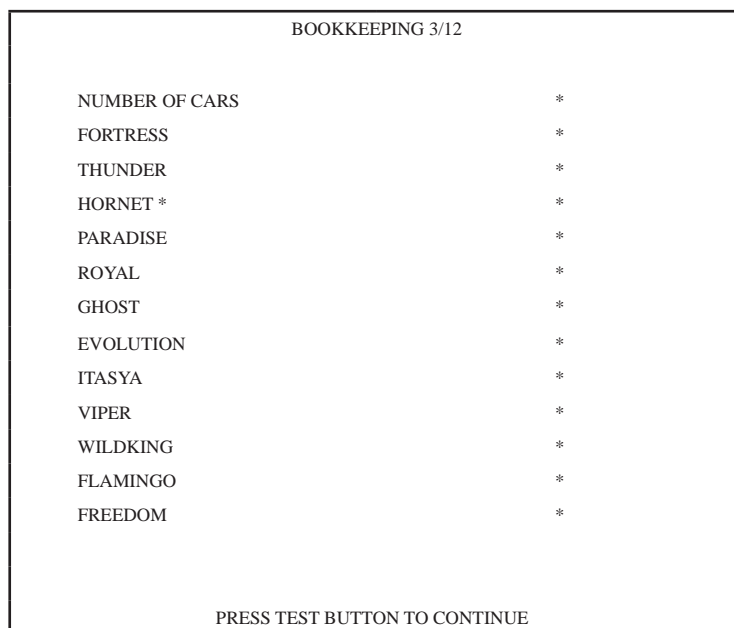

BOOKKEEPING 3/12

<b>NUMBER OF CARS</b>	Counts for all the selection of cars in the game.
<b>FORTRESS</b>	Counts for selection of FORTRESS in the game.
<b>THUNDER</b>	Counts for selection of THUNDER in the game.
<b>HORNET</b>	Counts for selection of HORNET in the game.
<b>PARADISE</b>	Counts for selection of PARADISE in the game.
<b>ROYAL</b>	Counts for selection of ROYAL in the game.
<b>GHOST</b>	Counts for selection of GHOST in the game.
<b>EVOLUTION</b>	Counts for selection of EVOLUTION in the game.
<b>ITASYA</b>	Counts for selection of ITASYA in the game.
<b>VIPER</b>	Counts for selection of VIPER in the game.
<b>WILDKING</b>	Counts for selection of WILDKING in the game.
<b>FLAMINGO</b>	Counts for selection of FLAMINGO in the game.
<b>FREEDOM</b>	Counts for selection of FREEDOM in the game.

BOOKKEEPING 4/12	
NUMBER OF COURSES	*
CANADA 1	*
CANADA 2	*
CANADA 3	*
CANADA 4	*
EGYPT 1	*
EGYPT 2	*
EGYPT 3	*
EGYPT 4	*
LASVEGAS 1	*
LASVEGAS 2	*
LASVEGAS 3	*
LASVEGAS 4	*
SHANGHAI 1	*
SHANGHAI 2	*
SHANGHAI 3	*
SHANGHAI 4	*
LONDON 1	*
LONDON 2	*
LONDON 3	*
LONDON 4	*
PRESS TEST BUTTON TO CONTINUE	

BOOKKEEPING 4/12

<b>NUMBER OF COURSES</b>	Counts for all the selection of courses in the game.
<b>CANADA1</b>	Counts for selection of CANADA1 in the game.
<b>CANADA2</b>	Counts for selection of CANADA2 in the game.
<b>CANADA3</b>	Counts for selection of CANADA3 in the game.
<b>CANADA4</b>	Counts for selection of CANADA4 in the game.
<b>EGYPT1</b>	Counts for selection of EGYPT1 in the game.
<b>EGYPT2</b>	Counts for selection of EGYPT2 in the game.
<b>EGYPT3</b>	Counts for selection of EGYPT3 in the game.
<b>EGYPT4</b>	Counts for selection of EGYPT4 in the game.
<b>LASVEGAS1</b>	Counts for selection of LASVEGAS1 in the game.
<b>LASVEGAS2</b>	Counts for selection of LASVEGAS2 in the game.
<b>LASVEGAS3</b>	Counts for selection of LASVEGAS3 in the game.
<b>LASVEGAS4</b>	Counts for selection of LASVEGAS4 in the game.
<b>SHANGHAI1</b>	Counts for selection of SHANGHAI1 in the game.
<b>SHANGHAI2</b>	Counts for selection of SHANGHAI2 in the game.
<b>SHANGHAI3</b>	Counts for selection of SHANGHAI3 in the game.
<b>SHANGHAI4</b>	Counts for selection of SHANGHAI4 in the game.
<b>LONDON1</b>	Counts for selection of LONDON1 in the game.
<b>LONDON2</b>	Counts for selection of LONDON2 in the game.
<b>LONDON3</b>	Counts for selection of LONDON3 in the game.
<b>LONDON4</b>	counts for selection of LONDON4 in the game.

BOOKKEEPING 5/12

NUMBER OF FIRSTS	*
CANADA 1	*
CANADA 2	*
CANADA 3	*
CANADA 4	*
EGYPT 1	*
EGYPT 2	*
EGYPT 3	*
EGYPT 4	*
LASVEGAS 1	*
LASVEGAS 2	*
LASVEGAS 3	*
LASVEGAS 4	*
SHANGHAI 1	*
SHANGHAI 2	*
SHANGHAI 3	*
SHANGHAI 4	*
LONDON 1	*
LONDON 2	*
LONDON 3	*
LONDON 4	*

PRESS TEST BUTTON TO CONTINUE

BOOKKEEPING 5/12

<b>NUMBER OF FIRST</b>	Counts for all the first place wins in the game.
<b>CANADA1</b>	Counts for first place win in CANADA1
<b>CANADA2</b>	Counts for first place win in CANADA2
<b>CANADA3</b>	Counts for first place win in CANADA3
<b>CANADA4</b>	Counts for first place win in CANADA4
<b>EGYPT1</b>	Counts for first place win in EGYPT1
<b>EGYPT2</b>	Counts for first place win in EGYPT2
<b>EGYPT3</b>	Counts for first place win in EGYPT3
<b>EGYPT4</b>	Counts for first place win in EGYPT4
<b>LASVEGAS1</b>	Counts for first place win in LASVEGAS1
<b>LASVEGAS2</b>	Counts for first place win in LASVEGAS2
<b>LASVEGAS3</b>	Counts for first place win in LASVEGAS3
<b>LASVEGAS4</b>	Counts for first place win in LASVEGAS4
<b>SHANGHAI1</b>	Counts for first place win in SHANGHAI1
<b>SHANGHAI2</b>	Counts for first place win in SHANGHAI2
<b>SHANGHAI3</b>	Counts for first place win in SHANGHAI3
<b>SHANGHAI4</b>	Counts for first place win in SHANGHAI4
<b>LONDON1</b>	Counts for first place win in LONDON1
<b>LONDON2</b>	Counts for first place win in LONDON2
<b>LONDON3</b>	Counts for first place win in of LONDON3
<b>LONDON4</b>	Counts for first place win in of LONDON4

BOOKKEEPING 6/12	
NUMBER OF SECONDS	*
CANADA 1	*
CANADA 2	*
CANADA 3	*
CANADA 4	*
EGYPT 1	*
EGYPT 2	*
EGYPT 3	*
EGYPT 4	*
LASVEGAS 1	*
LASVEGAS 2	*
LASVEGAS 3	*
LASVEGAS 4	*
SHANGHAI 1	*
SHANGHAI 2	*
SHANGHAI 3	*
SHANGHAI 4	*
LONDON 1	*
LONDON 2	*
LONDON 3	*
LONDON 4	*
PRESS TEST BUTTON TO CONTINUE	

BOOKKEEPING 6/12

NUMBER OF SECOND	Counts for all the second place wins in the game.
CANADA1	Counts for second place win in CANADA1
CANADA2	Counts for second place win in CANADA2
CANADA3	Counts for second place win in CANADA3
CANADA4	Counts for second place win in CANADA4
EGYPT1	Counts for second place win in EGYPT1
EGYPT2	Counts for second place win in EGYPT2
EGYPT3	Counts for second place win in EGYPT3
EGYPT4	Counts for second place win in EGYPT4
LASVEGAS1	Counts for second place win in LASVEGAS1
LASVEGAS2	Counts for second place win in LASVEGAS2
LASVEGAS3	Counts for second place win in LASVEGAS3
LASVEGAS4	Counts for second place win in LASVEGAS4
SHANGHAI1	Counts for second place win in SHANGHAI1
SHANGHAI2	Counts for second place win in SHANGHAI2
SHANGHAI3	Counts for second place win in SHANGHAI3
SHANGHAI4	Counts for second place win in SHANGHAI4
LONDON1	Counts for second place win in LONDON1
LONDON2	Counts for second place win in LONDON2
LONDON3	Counts for second place win in of LONDON3
LONDON4	Counts for second place win in of LONDON4

BOOKKEEPING 7/12

NUMBER OF THIRD	*
CANADA 1	*
CANADA 2	*
CANADA 3	*
CANADA 4	*
EGYPT 1	*
EGYPT 2	*
EGYPT 3	*
EGYPT 4	*
LASVEGAS 1	*
LASVEGAS 2	*
LASVEGAS 3	*
LASVEGAS 4	*
SHANGHAI 1	*
SHANGHAI 2	*
SHANGHAI 3	*
SHANGHAI 4	*
LONDON 1	*
LONDON 2	*
LONDON 3	*
LONDON 4	*

PRESS TEST BUTTON TO CONTINUE

BOOKKEEPING 7/12

<b>NUMBER OF THIRD</b>	Counts for all the third place wins in the game.
<b>CANADA1</b>	Counts for third place win in CANADA1
<b>CANADA2</b>	Counts for third place win in CANADA2
<b>CANADA3</b>	Counts for third place win in CANADA3
<b>CANADA4</b>	Counts for third place win in CANADA4
<b>EGYPT1</b>	Counts for third place win in EGYPT1
<b>EGYPT2</b>	Counts for third place win in EGYPT2
<b>EGYPT3</b>	Counts for third place win in EGYPT3
<b>EGYPT4</b>	Counts for third place win in EGYPT4
<b>LASVEGAS1</b>	Counts for third place win in LASVEGAS1
<b>LASVEGAS2</b>	Counts for third place win in LASVEGAS2
<b>LASVEGAS3</b>	Counts for third place win in LASVEGAS3
<b>LASVEGAS4</b>	Counts for third place win in LASVEGAS4
<b>SHANGHAI1</b>	Counts for third place win in SHANGHAI1
<b>SHANGHAI2</b>	Counts for third place win in SHANGHAI2
<b>SHANGHAI3</b>	Counts for third place win in SHANGHAI3
<b>SHANGHAI4</b>	Counts for third place win in SHANGHAI4
<b>LONDON1</b>	Counts for third place win in LONDON1
<b>LONDON2</b>	Counts for third place win in LONDON2
<b>LONDON3</b>	Counts for third place win in LONDON3
<b>LONDON4</b>	Counts for third place win in LONDON4

BOOKKEEPING 8/12	
NUMBER OF FOURTH	*
CANADA 1	*
CANADA 2	*
CANADA 3	*
CANADA 4	*
EGYPT 1	*
EGYPT 2	*
EGYPT 3	*
EGYPT 4	*
LASVEGAS 1	*
LASVEGAS 2	*
LASVEGAS 3	*
LASVEGAS 4	*
SHANGHAI 1	*
SHANGHAI 2	*
SHANGHAI 3	*
SHANGHAI 4	*
LONDON 1	*
LONDON 2	*
LONDON 3	*
LONDON 4	*
PRESS TEST BUTTON TO CONTINUE	

BOOKKEEPING 8/12

<b>NUMBER OF FOURTH</b>	Counts for all the fourth place wins in the game.
<b>CANADA1</b>	Counts for fourth place win in CANADA1
<b>CANADA2</b>	Counts for fourth place win in CANADA2
<b>CANADA3</b>	Counts for fourth place win in CANADA3
<b>CANADA4</b>	Counts for fourth place win in CANADA4
<b>EGYPT1</b>	Counts for fourth place win in EGYPT1
<b>EGYPT2</b>	Counts for fourth place win in EGYPT2
<b>EGYPT3</b>	Counts for fourth place win in EGYPT3
<b>EGYPT4</b>	Counts for fourth place win in EGYPT4
<b>LASVEGAS1</b>	Counts for fourth place win in LASVEGAS1
<b>LASVEGAS2</b>	Counts for fourth place win in LASVEGAS2
<b>LASVEGAS3</b>	Counts for fourth place win in LASVEGAS3
<b>LASVEGAS4</b>	Counts for fourth place win in LASVEGAS4
<b>SHANGHAI1</b>	Counts for fourth place win in SHANGHAI1
<b>SHANGHAI2</b>	Counts for fourth place win in SHANGHAI2
<b>SHANGHAI3</b>	Counts for fourth place win in SHANGHAI3
<b>SHANGHAI4</b>	Counts for fourth place win in SHANGHAI4
<b>LONDON1</b>	Counts for fourth place win in LONDON1
<b>LONDON2</b>	Counts for fourth place win LONDON2
<b>LONDON3</b>	Counts for fourth place win in LONDON3
<b>LONDON4</b>	Counts for fourth place win in LONDON4



BOOKKEEPING 9/12

NUMBER OF FIFTH	*
CANADA 1	*
CANADA 2	*
CANADA 3	*
CANADA 4	*
EGYPT 1	*
EGYPT 2	*
EGYPT 3	*
EGYPT 4	*
LASVEGAS 1	*
LASVEGAS 2	*
LASVEGAS 3	*
LASVEGAS 4	*
SHANGHAI 1	*
SHANGHAI 2	*
SHANGHAI 3	*
SHANGHAI 4	*
LONDON 1	*
LONDON 2	*
LONDON 3	*
LONDON 4	*

PRESS TEST BUTTON TO CONTINUE

BOOKKEEPING 9/12

<b>NUMBER OF FIFTH</b>	Counts for all the fifth place wins in the game.
<b>CANADA1</b>	Counts for fifth place win in CANADA1
<b>CANADA2</b>	Counts for fifth place win in CANADA2
<b>CANADA3</b>	Counts for fifth place win in CANADA3
<b>CANADA4</b>	Counts for fifth place win in CANADA4
<b>EGYPT1</b>	Counts for fifth place win in EGYPT1
<b>EGYPT2</b>	Counts for fifth place win in EGYPT2
<b>EGYPT3</b>	Counts for fifth place win in EGYPT3
<b>EGYPT4</b>	Counts for fifth place win in EGYPT4
<b>LASVEGAS1</b>	Counts for fifth place win in LASVEGAS1
<b>LASVEGAS2</b>	Counts for fifth place win in LASVEGAS2
<b>LASVEGAS3</b>	Counts for fifth place win in LASVEGAS3
<b>LASVEGAS4</b>	Counts for fifth place win in LASVEGAS4
<b>SHANGHAI1</b>	Counts for fifth place win in SHANGHAI1
<b>SHANGHAI2</b>	Counts for fifth place win in SHANGHAI2
<b>SHANGHAI3</b>	Counts for fifth place win in SHANGHAI3
<b>SHANGHAI4</b>	Counts for fifth place win in SHANGHAI4
<b>LONDON1</b>	Counts for fifth place win in LONDON1
<b>LONDON2</b>	Counts for fifth place win in LONDON2
<b>LONDON3</b>	Counts for fifth place win in LONDON3
<b>LONDON4</b>	Counts for fifth place win in LONDON4

BOOKKEEPING 10/12	
NUMBER OF SIXTH	*
CANADA 1	*
CANADA 2	*
CANADA 3	*
CANADA 4	*
EGYPT 1	*
EGYPT 2	*
EGYPT 3	*
EGYPT 4	*
LASVEGAS 1	*
LASVEGAS 2	*
LASVEGAS 3	*
LASVEGAS 4	*
SHANGHAI 1	*
SHANGHAI 2	*
SHANGHAI 3	*
SHANGHAI 4	*
LONDON 1	*
LONDON 2	*
LONDON 3	*
LONDON 4	*
PRESS TEST BUTTON TO CONTINUE	

BOOKKEEPING 10/12

<b>NUMBER OF SIXTH</b>	Counts for all the sixth place wins in the game.
<b>CANADA1</b>	Counts for sixth place win in CANADA1
<b>CANADA2</b>	Counts for sixth place win in CANADA2
<b>CANADA3</b>	Counts for sixth place win in CANADA3
<b>CANADA4</b>	Counts for sixth place win in CANADA4
<b>EGYPT1</b>	Counts for sixth place win in EGYPT1
<b>EGYPT2</b>	Counts for sixth place win in EGYPT2
<b>EGYPT3</b>	Counts for sixth place win in EGYPT3
<b>EGYPT4</b>	Counts for sixth place win in EGYPT4
<b>LASVEGAS1</b>	Counts for sixth place win in LASVEGAS1
<b>LASVEGAS2</b>	Counts for sixth place win in LASVEGAS2
<b>LASVEGAS3</b>	Counts for sixth place win in LASVEGAS3
<b>LASVEGAS4</b>	Counts for sixth place win in LASVEGAS4
<b>SHANGHAI1</b>	Counts for sixth place win in SHANGHAI1
<b>SHANGHAI2</b>	Counts for sixth place win in SHANGHAI2
<b>SHANGHAI3</b>	Counts for sixth place win in SHANGHAI3
<b>SHANGHAI4</b>	Counts for sixth place win in SHANGHAI4
<b>LONDON1</b>	Counts for sixth place win in LONDON1
<b>LONDON2</b>	Counts for sixth place win in LONDON2
<b>LONDON3</b>	Counts for sixth place win in LONDON3
<b>LONDON4</b>	Counts for sixth place win in LONDON4

BOOKKEEPING 11/12	
NUMBER OF SEVENTH	*
CANADA 1	*
CANADA 2	*
CANADA 3	*
CANADA 4	*
EGYPT 1	*
EGYPT 2	*
EGYPT 3	*
EGYPT 4	*
LASVEGAS 1	*
LASVEGAS 2	*
LASVEGAS 3	*
LASVEGAS 4	*
SHANGHAI 1	*
SHANGHAI 2	*
SHANGHAI 3	*
SHANGHAI 4	*
LONDON 1	*
LONDON 2	*
LONDON 3	*
LONDON 4	*
PRESS TEST BUTTON TO CONTINUE	

BOOKKEEPING 11/12

<b>NUMBER OF SEVENTH</b>	Counts for all the seventh place wins in the game.
<b>CANADA1</b>	Counts for seventh place win in CANADA1
<b>CANADA2</b>	Counts for seventh place win in CANADA2
<b>CANADA3</b>	Counts for seventh place win in CANADA3
<b>CANADA4</b>	Counts for seventh place win in CANADA4
<b>EGYPT1</b>	Counts for seventh place win in EGYPT1
<b>EGYPT2</b>	Counts for seventh place win in EGYPT2
<b>EGYPT3</b>	Counts for seventh place win in EGYPT3
<b>EGYPT4</b>	Counts for seventh place win in EGYPT4
<b>LASVEGAS1</b>	Counts for seventh place win in LASVEGAS1
<b>LASVEGAS2</b>	Counts for seventh place win in LASVEGAS2
<b>LASVEGAS3</b>	Counts for seventh place win in LASVEGAS3
<b>LASVEGAS4</b>	Counts for seventh place win in LASVEGAS4
<b>SHANGHAI1</b>	Counts for seventh place win in SHANGHAI1
<b>SHANGHAI2</b>	Counts for seventh place win in SHANGHAI2
<b>SHANGHAI3</b>	Counts for seventh place win in SHANGHAI3
<b>SHANGHAI4</b>	Counts for seventh place win in SHANGHAI4
<b>LONDON1</b>	Counts for seventh place win in LONDON1
<b>LONDON2</b>	Counts for seventh place win in LONDON2
<b>LONDON3</b>	Counts for seventh place win in LONDON3
<b>LONDON4</b>	Counts for seventh place win in LONDON4

BOOKKEEPING 12/12	
NUMBER OF EIGHTH	*
CANADA 1	*
CANADA 2	*
CANADA 3	*
CANADA 4	*
EGYPT 1	*
EGYPT 2	*
EGYPT 3	*
EGYPT 4	*
LASVEGAS 1	*
LASVEGAS 2	*
LASVEGAS 3	*
LASVEGAS 4	*
SHANGHAI 1	*
SHANGHAI 2	*
SHANGHAI 3	*
SHANGHAI 4	*
LONDON 1	*
LONDON 2	*
LONDON 3	*
LONDON 4	*
PRESS TEST BUTTON TO CONTINUE	

BOOKKEEPING 12/12

<b>NUMBER OF EIGHTH</b>	Counts for all the eighth place wins in the game.
<b>CANADA1</b>	Counts for eighth place win in CANADA1
<b>CANADA2</b>	Counts for eighth place win in CANADA2
<b>CANADA3</b>	Counts for eighth place win in CANADA3
<b>CANADA4</b>	Counts for eighth place win in CANADA4
<b>EGYPT1</b>	Counts for eighth place win in EGYPT1
<b>EGYPT2</b>	Counts for eighth place win in EGYPT2
<b>EGYPT3</b>	Counts for eighth place win in EGYPT3
<b>EGYPT4</b>	Counts for eighth place win in EGYPT4
<b>LASVEGAS1</b>	Counts for eighth place win in LASVEGAS1
<b>LASVEGAS2</b>	Counts for eighth place win in LASVEGAS2
<b>LASVEGAS3</b>	Counts for eighth place win in LASVEGAS3
<b>LASVEGAS4</b>	Counts for eighth place win in LASVEGAS4
<b>SHANGHAI1</b>	Counts for eighth place win in SHANGHAI1
<b>SHANGHAI2</b>	Counts for eighth place win in SHANGHAI2
<b>SHANGHAI3</b>	Counts for eighth place win in SHANGHAI3
<b>SHANGHAI4</b>	Counts for eighth place win in SHANGHAI4
<b>LONDON1</b>	Counts for eighth place win in LONDON1
<b>LONDON2</b>	Counts for eighth place win in LONDON2
<b>LONDON3</b>	Counts for eighth place win in LONDON3
<b>LONDON4</b>	Counts for eighth place win in LONDON4

### 9-3-3 INPUT TEST

Select INPUT TEST to display the following screen and check the status of input devices. This test should be used periodically to check that each input device is functioning correctly.

INPUT TEST	
PLAYER	1
STEERING	**
GAS	**
BRAKE	**
START/WEAPON	OFF
TEST	OFF
SERVICE	OFF
SELECT WITH SERVICE	
AND PRESS TEST BUTTON	

INPUT TEST screen

■ **Controls**

- Input devices are working correctly if the corresponding menu item switches from OFF to ON when the device is operated.
- Press the TEST Button and the SERVICE Button simultaneously to return to GAME TEST MENU screen.

■ **Menu Items**

<b>STEERING</b>	Turn the steering wheel to left, the Steering wheel value will go small, turn right, the value will go big.
<b>GAS</b>	Press the accelerator pedal, the Gas value will change.
<b>BRAKE</b>	Press the brake pedal, the Brake value will change.
<b>START/WEAPON</b>	Press START/WEAPON button, this item will display "ON", release the button, the item will display "OFF".
<b>TEST</b>	Press Test Button, this item will display "ON", release this button, the item will display "OFF".
<b>SERVICE</b>	Press Service Button, this item will display "ON", release the button, the item will display "OFF".

## 9-3-4 OUTPUT TEST

This screen is for confirming the proper operation of each output device used by the game. Periodically use this screen to check the status of each output device.

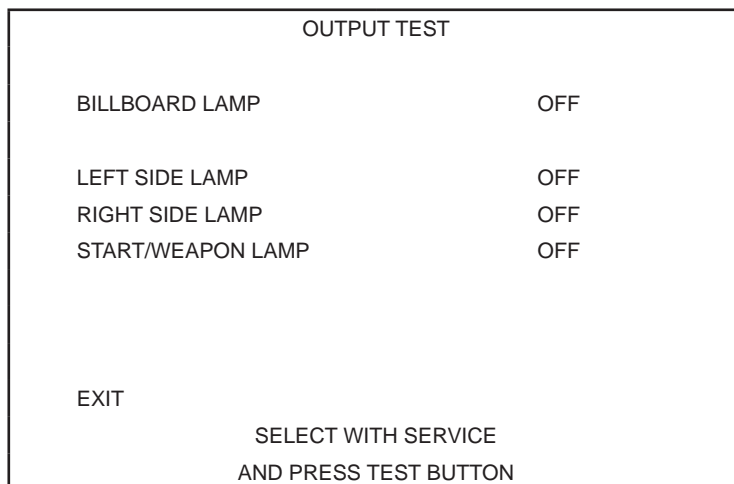

OUTPUT TEST screen

### ■Controls

- Press the SERVICE Button to select menu item.
- When the TEST Button is being pressed, the selected item will change from OFF to ON and the corresponding output device will operate.
- When the TEST Button is released, the selected item will change from ON to OFF and the corresponding output device will cease operation.
- Select EXIT and press the TEST Button to return to the GAME TEST MENU screen.

### ■Menu Items

<b>BILLBOARD LAMP</b>	Light of billboard.	
<b>LEFT SIDE LAMP</b>	Light on left side of cabinet.	“OFF RED GREEN BLUE WHITE”5 levels adjustment.
<b>RIGHT SIDE LAMP</b>	Light on right side of cabinet.	“OFF RED GREEN BLUE WHITE”5 levels adjustment.
<b>START/WEAPON BUTTON LAMP</b>	Light of START/WEAPON button.	“OFF RED GREEN BLUE WHITE”5 levels adjustment

## 9-3-5 GAME ASSIGNMENTS

Adjust all game settings.

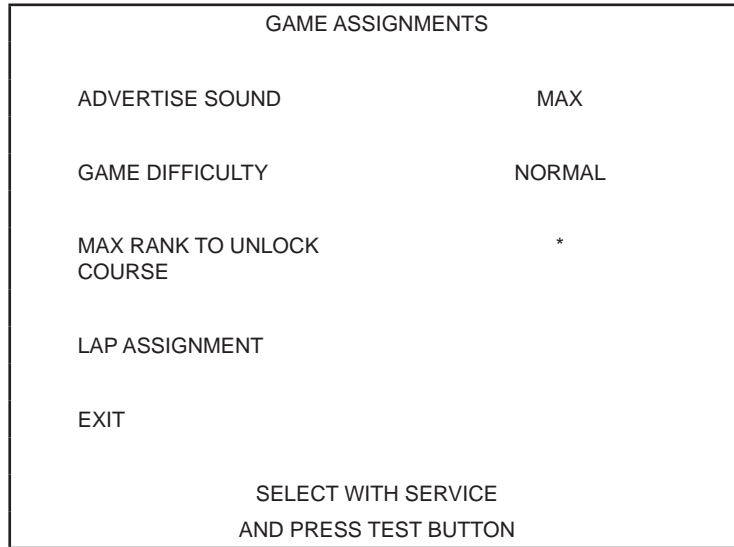

GAME ASSIGNMENTS screen

### ■ Controls

- Press the SERVICE Button to select menu item.
- Press the TEST Button to change the value of the selected item.
- Select EXIT and press the TEST Button to return to the GAME TEST MENU screen.

### ■ Menu Items

ADVERTISE SOUND	Set the volume of attraction movie	"MAX - 3/4 - 1/2 - 1/4 - OFF" 5 levels adjustment. Closer to "off", lower the volume will be.
GAME DIFFICULTY	Set Game Difficulty	Game difficulty has been divided into 5 levels: "VERY EASY" -> "EASY" -> "NORMAL" -> "HARD" -> "VERY HARD", Closer to "VERY HARD", harder the game will be.
MAX RANK TO UNLOCK COURSES	Set UNLOCK feature	Set to "ON", the system will unlock course when the player win the race in * place.
POST GIRL	Display "POST GIRL"	Set to "ON", the system will display post girl.
LAPS ASSIGNMENT	Set amount of laps	Adjust the default laps of courses from 1 to 4.

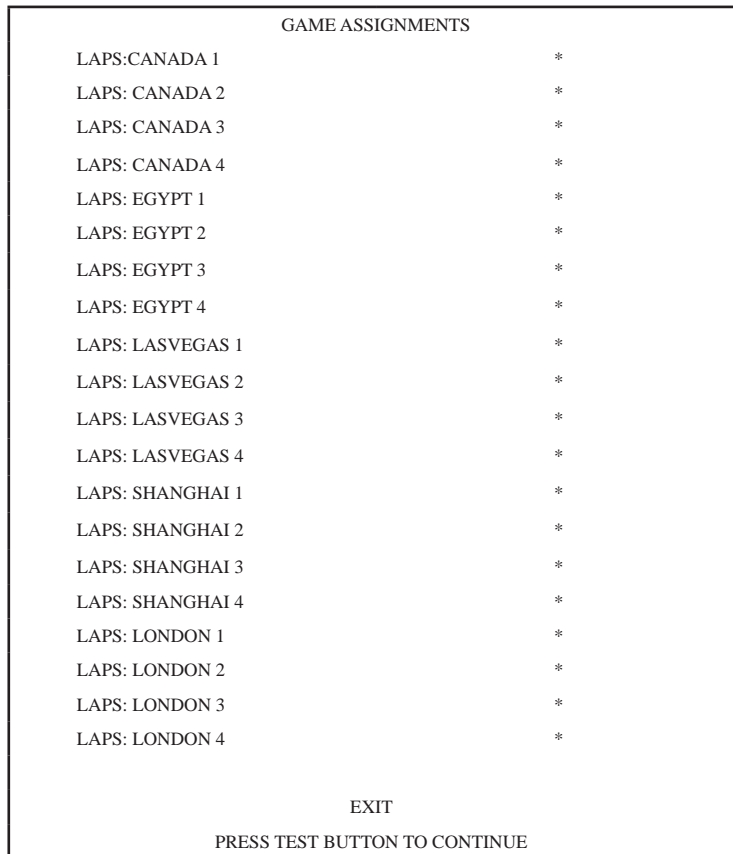

**LAP SETTING SCREEN**

■ **Controls**

- Press the SERVICE Button to select menu item.
- Press the TEST Button to change the value of the selected item.
- Select EXIT and press the TEST Button to return to the GAME ASSIGNMENTS screen.

■ **Menu Items**

LAPS:CANADA1	Set the laps number in CANADA1, from 1 to 4 laps
LAPS:CANADA2	Set the laps number in CANADA2, from 1 to 4 laps
LAPS:CANADA3	Set the laps number in CANADA3, from 1 to 4 laps
LAPS:CANADA4	Set the laps number in CANADA4, from 1 to 4 laps
LAPS:EGYPT1	Set the laps number in EGYPT1 , from 1 to 4 laps
LAPS:EGYPT2	Set the laps number in EGYPT2, from 1 to 4 laps
LAPS:EGYPT3	Set the laps number in EGYPT3 , from 1 to 4 laps
LAPS:EGYPT4	Set the laps number in EGYPT4 , from 1 to 4 laps
LAPS:LASVEGAS1	Set the laps number in LASVEGAS1 , from 1 to 4 laps
LAPS:LASVEGAS2	Set the laps number in LASVEGAS2, from 1 to 4 laps
LAPS:LASVEGAS3	Set the laps number in LASVEGAS3, from 1 to 4 laps
LAPS:LASVEGAS4	Set the laps number in LASVEGAS4 , from 1 to 4 laps
LAPS:SHANGHAI1	Set the laps number in SHANGHAI1 , from 1 to 4 laps
LAPS:SHANGHAI2	Set the laps number in SHANGHAI2 , from 1 to 4 laps
LAPS:SHANGHAI3	Set the laps number in SHANGHAI3 , from 1 to 4 laps
LAPS:SHANGHAI4	Set the laps number in SHANGHAI4 , from 1 to 4 laps
LAPS:LONDON1	Set the laps number in LONDON1 , from 1 to 4 laps
LAPS:LONDON2	Set the laps number in LONDON2, from 1 to 4 laps
LAPS:LONDON3	Set the laps number in LONDON3 , from 1 to 4 laps
LAPS:LONDON4	Set the laps number in LONDON4 , from 1 to 4 laps



## 9-3-6 TIME SETTING

Set game time for all aspects.

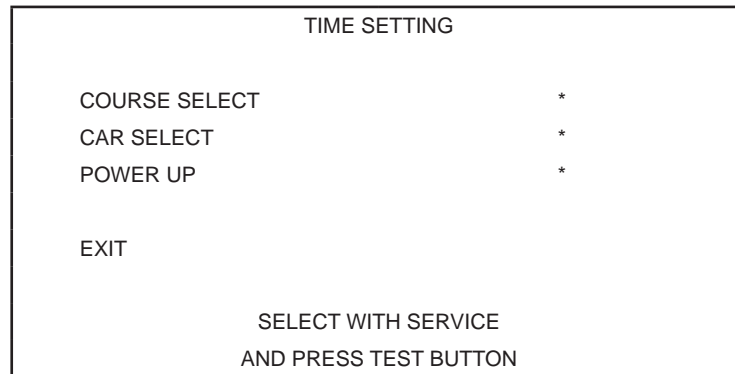

TIME ADJUSTMENT screen

### ■ Controls

- Press the SERVICE Button to select menu item.
- Press the TEST Button to change the value of the selected item.
- Select EXIT and press the TEST Button to return to the GAME TEST MENU screen.

### ■ Menu Items

COURSE SELECT	Set course select screen countdown time. 5->10->15->20->25->30. 6 levels in total.
CAR SELECT	Set car select screen countdown time. 5->10->15->20->25->30. 6 levels in total.
POWER UP	Set multi play waiting countdown time. 5->10->15->20->25->30. 6 levels in total.

## 9-3-7 BONUS SETTING

Bonus related setting.

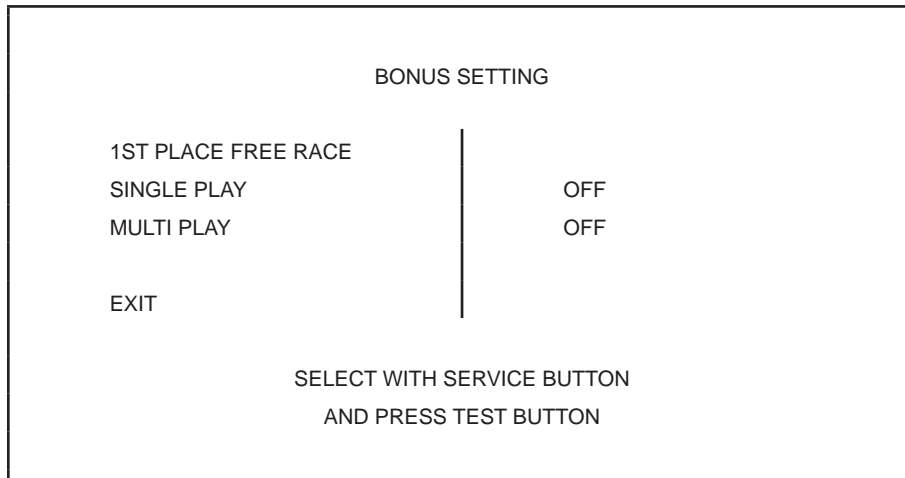

BONUS SETTING screen

### ■ Controls

- Press the SERVICE Button or START Button to select menu item.
- Select EXIT (WITH SAVE) and press the TEST Button to save the values you have set and return to the GAME TEST MENU screen.

### ■ Menu Items

1ST PLACE FREE RACE	First place is able to win free race.
SINGLE PLAY	First place is able to win free race in single play game.
MULTI PLAY	First place is able to win free race in multi play game.

\* PLEASE NOTE THAT BONUS SETTINGS ARE NOT DISPLAYED FOR EU/USA MARKETS

### 9-3-8 LINK SETTING

When 2 or machines are connected, these options are available to select.

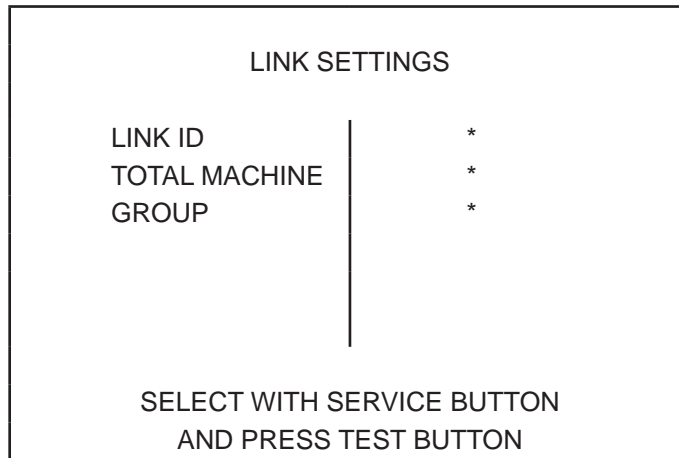

LINK SETTING screen

#### ■ Controls

- Press Service Button to select menu item.
- Press Test Button to run selected item.
- Select “EXIT” and press Test Button to return to “GAME TEST MODE” Screen.
- 

#### ■ Menu item

LINK ID	Set machine ID from 1 to 6. Same ID can't set twice in same group. Multiplay game can't start with incorrect setting.
TOTAL MACHINE	Set total machine number. Set the number of machine connected in current group. Every machine in same group must have same number. Multi play game can't start with incorrect setting.
GROUP	Machines are able to divide into different group from A to F. Machines in same group are able to start Multi Play competition.

## 9-3-9 FORCE FEEDBACK

This screen is for setting the strength of the steering wheel's force feedback.

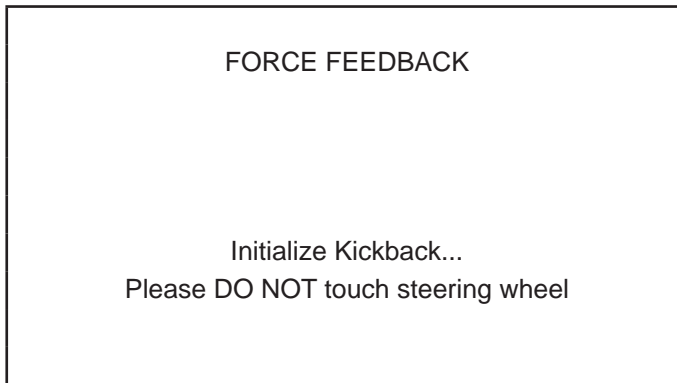

When the system initialization is complete, the FORCE FEEDBACK Screen will appear.

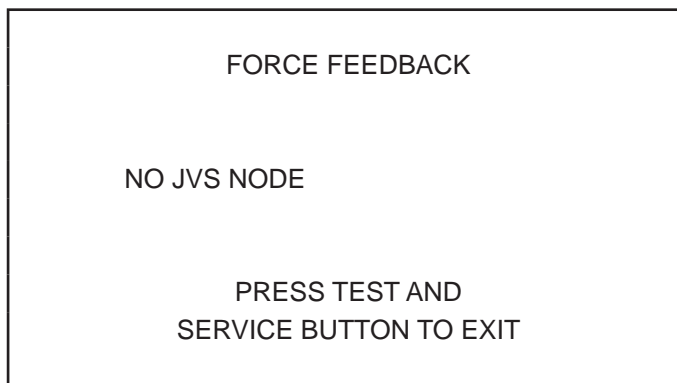

FORCE FEEDBACK Error Screen.

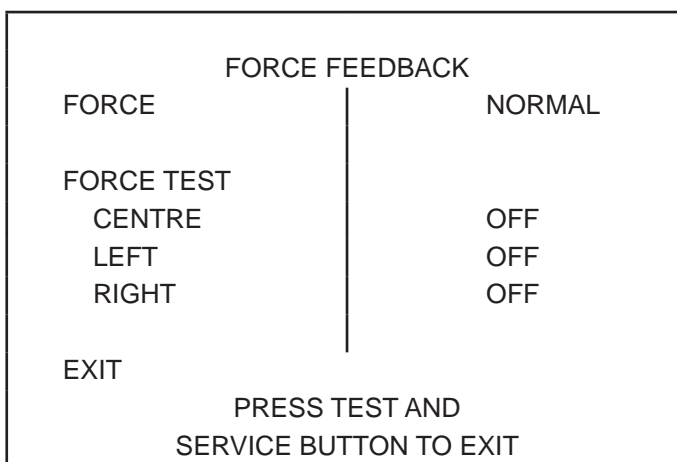

FORCE FEEDBACK Test Screen.

### ■ Controls

- Press Service Button to select menu item.
- Press Test Button to run selected item.

Select "EXIT" and press Test Button to return to "GAME TEST MODE" Screen.

## 9-3-10 INPUT ADJUSTMENTS

This screen is for setting the input device utilized in game.

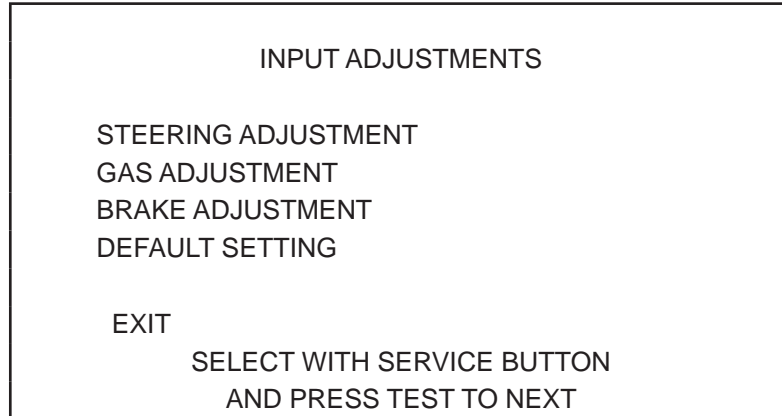

INPUT ADJUSTMENT SCREEN

### ■ Controls

- Press Service Button to select menu item.
- Press Test Button to run selected item.

Select "EXIT" and press Test Button to return to "GAME TEST MODE" Screen.

### ■ Menu Items

<b>STEERING ADJUSTMENTS</b>	Adjust the steering wheel
<b>GAS ADJUSTMENTS</b>	Adjust the input range of the accelerator device.
<b>BRAKE ADJUSTMENTS</b>	Adjust the input range of brake device.
<b>DEFAULT SETTING</b>	Return all the current settings to default settings.

### STEERING ADJUSTMENTS

This screen is for setting steering wheel.

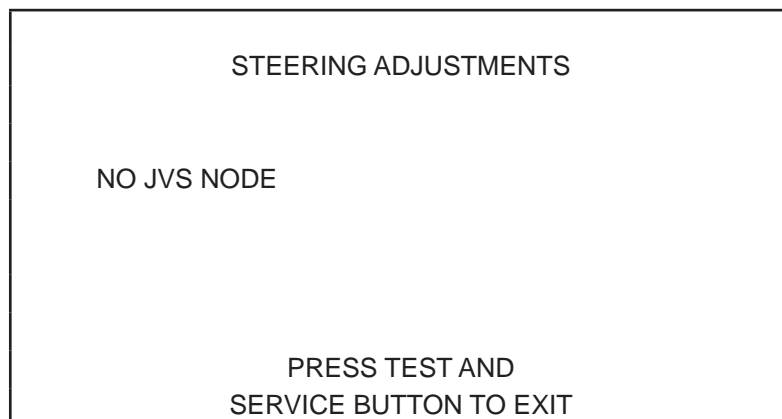

NO JVS NODE Connected Screen

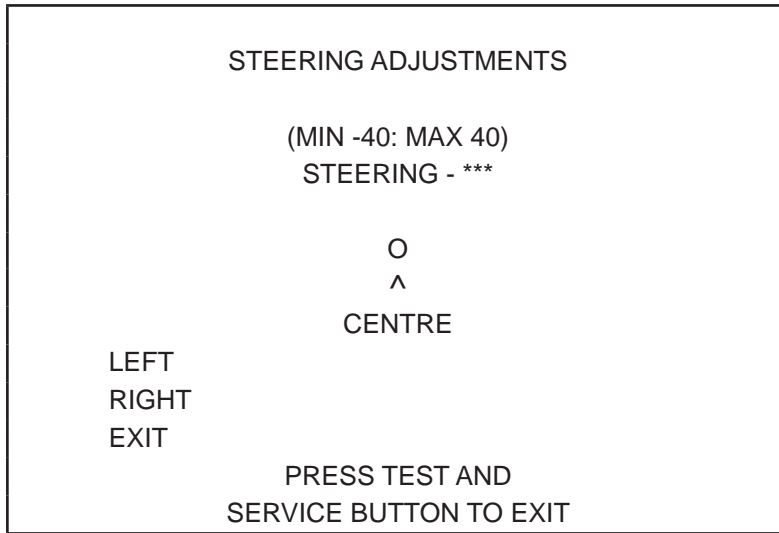

STEERING ADJUSTMENT Screen

■ Menu Items

(MIN -40:MAX 40)	Min and Max values
STEERING = ***	Display the output value of current steering setting
<p style="text-align: center;">O ^ CENTRE</p>	Displays current position/value of steering
LEFT	Adjust the current steering setting value (decrease)
RIGHT	Adjust the current steering setting value (increase)

■ Controls

Turn the steering wheel to center, the center point will move to center place.

When “O” mark and “^” mark does not match, press the Service Button to move the cursor to left and right and press Test Button.

Move “^” mark, and adjust “O” mark right under the “^” mark.

When the cursor is on “LEFT”, every time Test Button is pressed, “^” mark will move left.

When the cursor is on “RIGHT”, every time Test Button is pressed, “^” mark will move right.

When the adjustment is completed, select “EXIT” and return to “INPUT ADJUSTMENTS” Screen.

**GAS ADJUSTMENTS**

Gas standard setting in game.

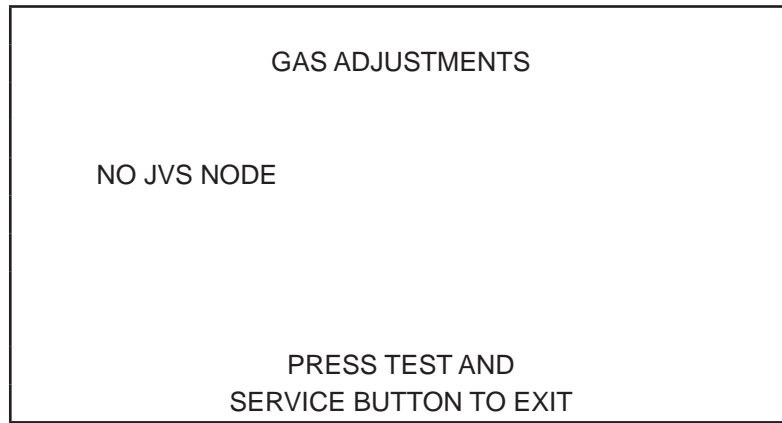

NO JVS NODE Connected Screen

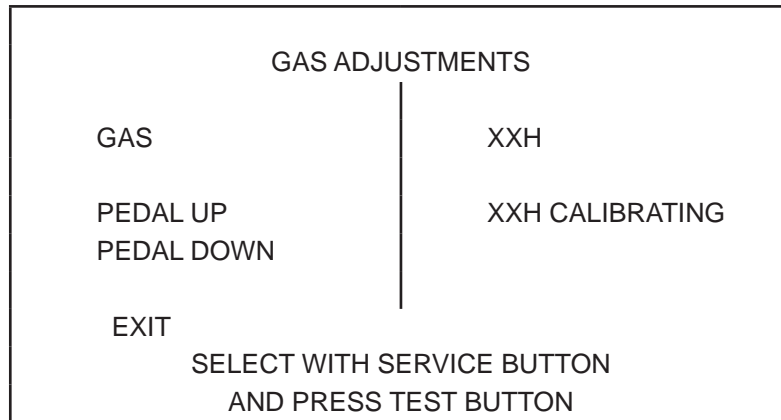

GAS ADJUSTMENT Screen

■ Menu Items

GAS	Display current value of accelerator pedal.
PEDAL UP	Display current value when accelerator pedal is up.
PEDAL DOWN	Display current value when accelerator pedal is down.

■ Control

Move the cursor to “PEDAL UP”, and press the Test Button. Information will be displayed behind this item: “CALIBRATING...PRESS TEST TO SET”, release the accelerator and press Test Button again to record adjusted value.

Move the cursor to ”PEDAL DOWN”, and press the Test Button. Information will be displayed behind this item: “CALIBRATING...PRESS TEST TO SET”, press on the accelerator and press Test Button again to record adjusted value.

After all the adjustment is done, select “EXIT” to return to “INPUT ADJUSTMENTS” Screen.

## **BRAKE ADJUSTMENTS**

Brake standard setting in game.

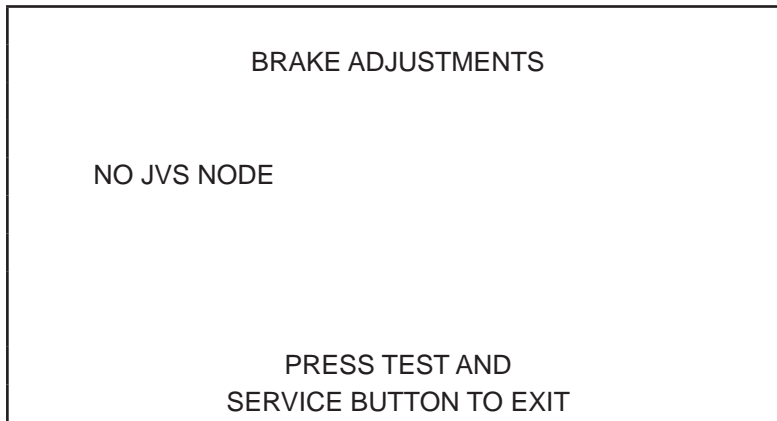

NO JVS NODE Connected Screen

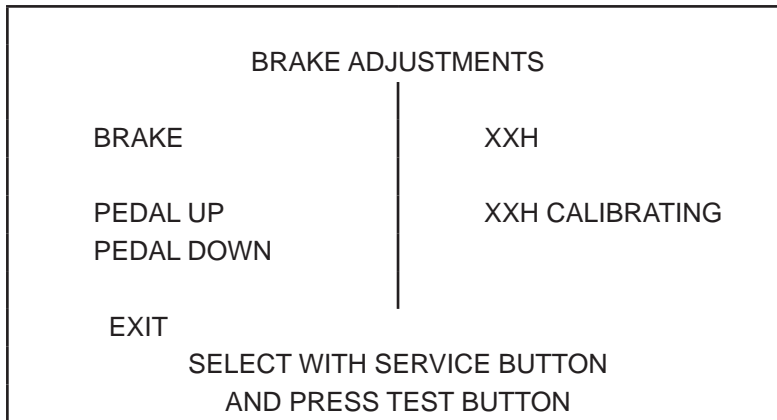

BRAKE ADJUSTMENT Screen

### ■ Menu Items

BRAKE	Display current value of brake pedal.
PEDAL UP	Display current value when brake pedal is up.
PEDAL DOWN	Display current value when brake pedal is down.

### ■ Control

Move the cursor to "PEDAL UP", and press the Test Button. Information will be displayed behind this item: "CALIBRATING...PRESS TEST TO SET", release the accelerator and press Test Button again to record adjusted value.

Move the cursor to "PEDAL DOWN", and press the Test Button. Information will be displayed behind this item: "CALIBRATING...PRESS TEST TO SET", press on the accelerator and press Test Button again to record adjusted value.

After all the adjustment is done, select "EXIT" to return to "INPUT ADJUSTMENTS" Screen.



**DEFAULT SETTING**

Reset all the adjustment value to default value.

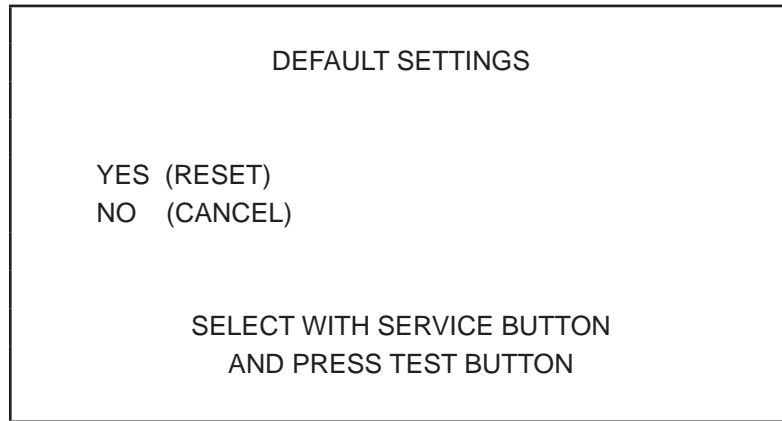

DEFAULT SETTING 1/2 Screen

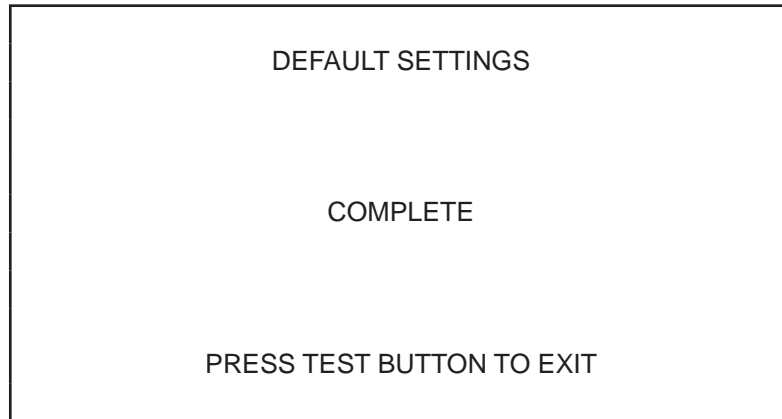

DEFAULT SETTING 2/2 Screen

■ **Control**

Press Service Button to select menu item.

Select “YES (RESET)” and press Test Button, all the adjusted value will reset to default value.

When “COMPLETED” is displayed, press Test Button again and return to “INPUT ADJUSTMENTS” Screen.

Select “NO(CANCEL)” and press Test Button, no action will be executed and return to “INPUT ADJUSTMENTS” Screen directly.

## 9-3-11 BACKUP DATA CLEAR

Clear all game records

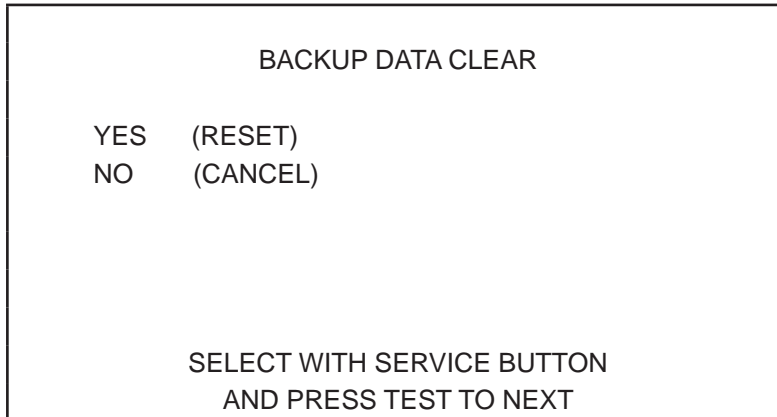

BACKUP DATA CLEAR creen 1/2



BACKUP DATA CLEAR creen 2/2

### ■ Controls

Press Service Button to select menu item.

Select “YES (CLEAR) and press Test Button to clear all backup data.

When “COMPLETED” is displayed, press Test Button again and return to “GAME TEST MODE” Screen.

Select “NO (CANCEL)” and press Test Button, no action will be executed and return to “GAME TEST MODE”

Screen directly.

## 9-4 SYSTEM INFORMATION

The SYSTEM INFORMATION screen displays system information.  
The following information is displayed on this screen.

### SYSTEM INFORMATION 1/2

The SYSTEM INFORMATION 1/2 screen displays system information.

#### ■ SYSTEM INFORMATION 1/2 Screen

SYSTEM INFORMATION 1/2	
KEYCHIP	
KEYCHIP ID	A72*_*****
MODEL TYPE	*
REGION	***
MOTHER BOARD	
MAIN ID	****_*****
OS VERSION	*****
REGION	**
MEMORY SIZE	****MB
STORAGE DEVICE	
STORAGE SIZE	*GB
GRAPHIC DEVICE	
DEVICE ID	****;****
PRESS TEST BUTTON TO NEXT	

The following information is displayed on this screen.

#### ● KEYCHIP

KEYCHIP ID	The serial number of the key chip.
MODEL TYPE	The model type.
REGION	The region setting of the key chip.

#### ● MOTHER BOARD

MAIN ID	The serial number of the game board.
OS VERSION	The system's OS version.
REGION	The region setting of the game board.
MEMORY SIZE	The onboard memory size.

#### ● STORAGE DEVICE

STORAGE SIZE	The total capacity of the program installer device.
--------------	---

#### ● GRAPHIC DEVICE

DEVICE ID	The graphic device's ID.
-----------	--------------------------

Press the TEST Button to move to the SYSTEM INFORMATION 2/2.

## SYSTEM INFORMATION 2/2

The SYSTEM INFORMATION 2/2 screen displays system information.

Press the TEST Button on the SYSTEM INFORMATION 2/2 screen to return to the SYSTEM TEST MODE screen.

### ■ SYSTEM INFORMATION 2/2 Screen

SYSTEM INFORMATION 2/2	
VOLTAGE CPU CORE	+*. **[V]
VOLTAGE 3.3V	+*. **[V]
VOLTAGE 5V	+**. **[V]
VOLTAGE 12V	+*. **[V]
VOLTAGE BATTERY	*****
FAN CPU	****[rpm]
FAN CHASSIS	****[rpm]
TEMP CPU	**[C]
TEMP CHASSIS	**[C]
PRESS TEST BUTTON TO EXIT	

The following information is displayed on this screen.

VOLTAGE CPU CORE	CPU core voltage
VOLTAGE 3.3V	3.3 V voltage
VOLTAGE 5V	5 V voltage
VOLTAGE 12V	12 V voltage
VOLTAGE BATTERY	Backup battery status
FAN CPU	CPU fan RPM
FAN CHASSIS	Case fan RPM
TEMP CPU	CPU temperature
TEMP CHASSIS	Case temperature

Press the TEST Button to return to the SYSTEM TEST MODE screen.

## 9-5 STORAGE INFORMATION

The STORAGE INFORMATION screen displays information on the game stored in the program installer device. This screen is also used when uninstalling the game stored within the program installer device.

Until preparations to launch the game are complete, a now checking screen will be displayed and uninstall cannot be performed.

If the program installer device does not contain any game data, "GAME PROGRAM NOT READY" screen will be displayed and uninstall cannot be performed.

*NOTE: If an uninstall is performed, an install will then have to be performed before the game board can be used again. Do not needlessly perform an uninstall.*

### ■ STORAGE INFORMATION Screen

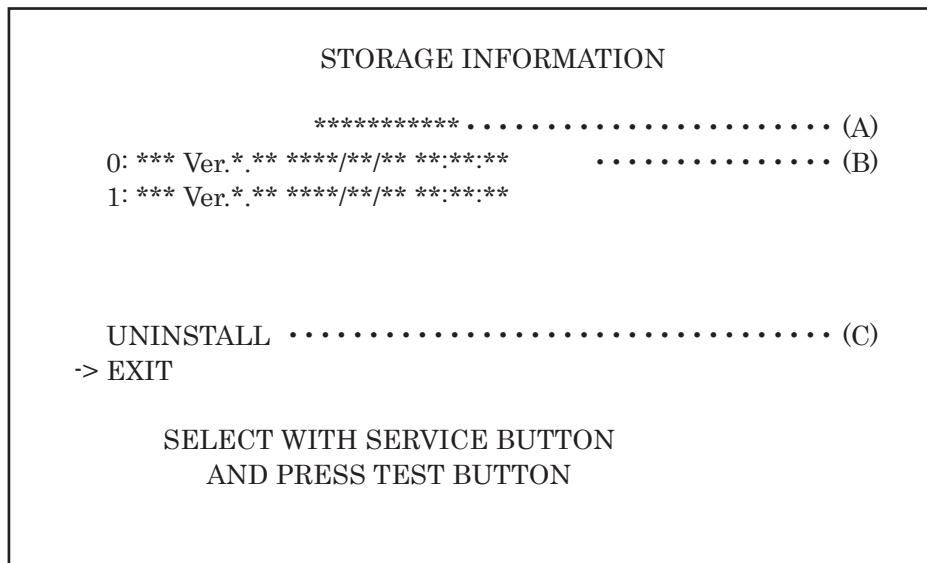

The following information is displayed on this screen.

#### (A) GAME TITLE

#### (B) INSTALLED GAME PROGRAM LIST

- GAME ID
- VERSION
- DATE & TIME OF RELEASE

#### (C) UNINSTALL

When preparations to launch the game are complete, it is possible to uninstall the game stored in the program installer device. Select UNINSTALL and then select "YES" to uninstall all game programs stored in the program installer device. Performing this operation will also mean that GAME TEST MODE will disappear from the SYSTEM TEST MODE screen.

Move the cursor to EXIT and press the TEST Button to return to the SYSTEM TEST MODE screen.

## 9-6 JVS TEST

The JVS TEST screen displays information on the connected JVS I/O boards.  
Select INPUT TEST to display input data for the currently displayed JVS I/O board.  
Select NODE to display information on the next NODE.  
Select EXIT to display information on the next NODE.  
If no JVS I/O boards are connected, the message "NO JVS NODE" will be displayed.

### ■ JVS TEST Screen

```

                                JVS TEST

INPUT TEST
NODE          1/*
-> EXIT
NAME          SEGA ENTERPRISES.LTD.:
              I/O BD JVS :837-13551:
              Ver1.00
              1.1
CMD VER       2.0
JVS VER       1.0
COM VER       1.0
SWITCH        2 PLAYER(S) 13 BIT[S]
COIN          2 SLOT(S)
ANALOG        8 CH
ROTARY        0 CH
KEYCODE       0
SCREEN        X:0 Y:0 CH:0
GENERAL IN    0 BIT(S)
CARD          0 SLOT(S)
HOPPER OUT    0 CH
DRIVER OUT    6 CH
ANALOG OUT    0 CH
CHARACTER     CHARA:0 LINE:0
BACKUP        0

                SELECT WITH SERVICE BUTTON
                AND PRESS TEST BUTTON
```

NOTE: The screen display will vary depending on the I/O board that is connected.  
The figure above is one example.

The following information is displayed on this screen.

NODE	The currently displayed JVS I/O board number and the total number of connected JVS I/O boards
NAME	Name of the connected I/O board, etc.
CMD VER	Command format version
JVS VER	JVS standard version
COM VER	Communication version
SWITCH	Number of players and number of 1P switches
COIN	Number of coin slots
ANALOG	Number of analog channels
ROTARY	Number of rotary encoders
KEYCODE	Keycode input active/inactive
SCREEN	Screen position input (X axis, Y axis, number of channels)
GENERAL IN	Number of standard switches
CARD	Number of card slots
HOPPER OUT	Number of hoppers
DRIVER OUT	Number of standard output drivers
ANALOG OUT	Number of analog output channels
CHARACTER	Number of characters/lines displayed
BACKUP	Backup present/absent

Move the cursor to EXIT and press the TEST Button to return to the SYSTEM TEST MODE screen.

## JVS INPUT TEST

Use the JVS INPUT TEST to test the JVS input.

The hexadecimal input information from the JVS I/O board will be displayed in real time.

### ■ JVS INPUT TEST Screen

JVS TEST INPUT TEST					
NODE	1/*				
SYSTEM		00	ROTARY	0	0000
PLAYER	1	0000	ROTARY	1	0000
PLAYER	2	0000	ROTARY	2	0000
COIN 1	0000	ROTARY	3	0000	
COIN 2	0000	ROTARY	4	0000	
ANALOG	0	0000	ROTARY	5	0000
ANALOG	1	0000	ROTARY	6	0000
ANALOG	2	0000	ROTARY	7	0000
ANALOG	3	0000			
ANALOG	4	0000			
ANALOG	5	0000			
ANALOG	6	0000			
ANALOG	7	0000			

PRESS TEST BUTTON AND  
SERVICE BUTTON TO EXIT

*NOTE: The screen display will vary depending on the I/O board that is connected.*

*The figure above is one example.*

The following information is displayed on this screen.

SYSTEM	System switch input data
PLAYER	Player number and player switch input data
COIN	Slot number and coin input data
ANALOG	Channel number and analog input data
ROTARY	Rotary number and rotary input data

Press the SERVICE and TEST Buttons simultaneously to return to the JVS TEST screen.



## 9-7 MONITOR TEST

Use MONITOR TEST to check the output of the monitor.

Enter MONITOR TEST and the MONITOR TEST 1/2 Screen will be displayed.

### ■ MONITOR TEST Screen 1/2

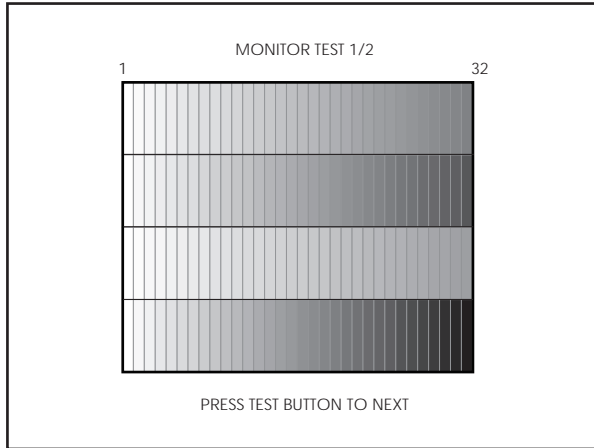

Press TEST Button and the screen will change to the MONITOR TEST 2/2 Screen.

### ■ MONITOR TEST Screen 2/2

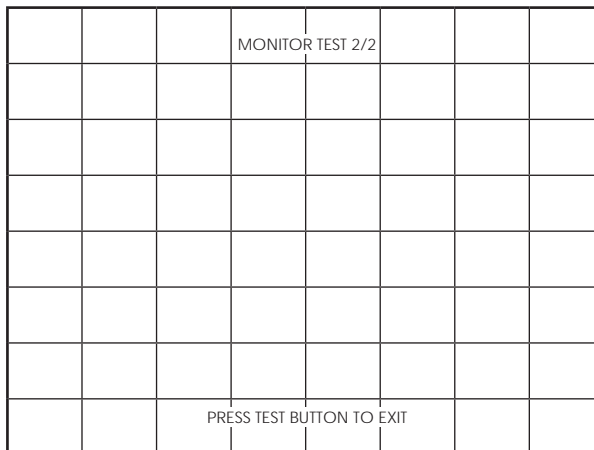

Press the TEST Button to return to the SYSTEM TEST MODE screen.

## 9-8 SPEAKER TEST

Use SPEAKER TEST to check the output of each speaker by having them each emit a test sound.

Select each speaker with the cursor and press the TEST Button to turn that speaker ON or OFF.

When set to ON a test sound will be emitted from that speaker.

It is possible to set multiple speakers to emit the test sound at the same time.

Depending on the cabinet used, some items will be displayed but no sound will be emitted.

### ■ SPEAKER TEST Screen

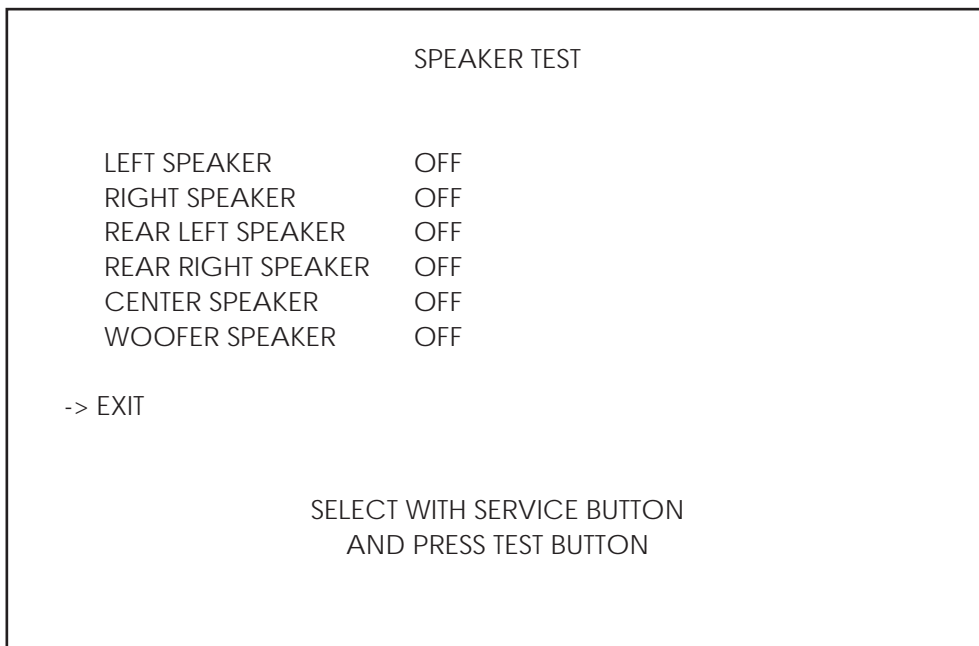

Move the cursor to EXIT and press the TEST Button to return to the SYSTEM TEST MODE screen.

## 9-9 COIN ASSIGNMENTS

Use COIN ASSIGNMENTS to alter the credit settings.

The game will award players the number of credits determined here.

Settings will only be saved if they have been changed.

### ■ COIN ASSIGNMENTS Screen

COIN ASSIGNMENTS

COIN CHUTE TYPE COMMON ..... (A)

SERVICE TYPE COMMON ..... (B)

COIN CHUTE #1 COIN TO CREDIT RATE ..... (C-1)

1 COIN(S) COUNT AS 1 CREDIT(S)

COIN CHUTE #2 COIN TO CREDIT RATE ..... (C-2)

1 COIN(S) COUNT AS 1 CREDIT(S)

DETAIL SETTING ..... (D)

GAME COST SETTING ..... (H)

-> EXIT ..... (I)

SELECT WITH SERVICE BUTTON  
AND PRESS TEST BUTTON

[COIN CHUTE TYPE: COMMON]

The following information is displayed on this screen.

#### (A) COIN CHUTE TYPE

COMMON	Allow all credits to be used by all players.
INDIVIDUAL	Treat each player's credits individually.

#### (B) SERVICE TYPE (Service Button Type)

COMMON	When the COIN CHUTE TYPE is set to COMMON, the number of credits available to all players will increase by 1.
	When the COIN CHUTE TYPE is set to INDIVIDUAL, each player's credits will increase by 1.
INDIVIDUAL	When the COIN CHUTE TYPE is set to COMMON, the number of credits available to all players will increase by 1.
	When the COIN CHUTE TYPE is set to INDIVIDUAL, the player corresponding to the SERVICE Button's credits will increase by 1.

**(C-1) COIN CHUTE #1 COIN TO CREDIT RATE (Coin and credit conversion rate 1)**

1 COIN(S) COUNT AS 1 CREDIT(S)	1 coin counts as 1 credit
2 COIN(S) COUNT AS 1 CREDIT(S)	2 coins count as 1 credit
3 COIN(S) COUNT AS 1 CREDIT(S)	3 coins count as 1 credit
4 COIN(S) COUNT AS 1 CREDIT(S)	4 coins count as 1 credit
5 COIN(S) COUNT AS 1 CREDIT(S)	5 coins count as 1 credit
1 COIN(S) COUNT AS 2 CREDIT(S)	1 coin counts as 2 credits
1 COIN(S) COUNT AS 3 CREDIT(S)	1 coin counts as 3 credits
1 COIN(S) COUNT AS 4 CREDIT(S)	1 coin counts as 4 credits
1 COIN(S) COUNT AS 5 CREDIT(S)	1 coin counts as 5 credits
FREE PLAY	Free play (no coins required)
DETAIL SETTING	More detailed settings

**(C-2) COIN CHUTE #2 COIN TO CREDIT RATE (Coin and credit conversion rate 2)**

When (A) COIN CHUTE TYPE is set to “COMMON,” the detail settings for this item are restricted to the settings listed in (C-1).

**(D) DETAIL SETTING**

The COIN ASSIGNMENTS DETAIL SETTING screen allows more detailed settings that cannot be performed on (C) the COIN TO CREDIT RATE screen to be performed.

■ **DETAIL SETTING Screen**

```

COIN ASSIGNMENTS
DETAIL SETTING

COIN CHUTE #1 MULTIPLIER ..... E-1
 1 COIN COUNT AS 1 COIN (S)
COIN CHUTE #2 MULTIPLIER ..... E-2
 1 COIN COUNT AS 1 COIN (S)
BONUS ADDER          NO BONUS ADDER ..... F
COIN TO CREDIT 1 COIN (S) 1 CREDIT ..... G
-> EXIT

COIN CHUTE #1 OPERATION
COIN  1  2  3  4  5  6  7  8  9
CREDIT 1  2  3  4  5  6  7  8  9

COIN CHUTE #2 OPERATION
COIN  1  2  3  4  5  6  7  8  9
CREDIT 1  2  3  4  5  6  7  8  9

SELECT WITH SERVICE BUTTON
AND PRESS TEST BUTTON
    
```

[COIN CHUTE TYPE: COMMON]

The following information is displayed on this screen.

**(E-1) COIN CHUTE #1 MULTIPLIER**

Coin conversion rate for #1. (How many coins 1 inserted coin counts for)

**(E-2) COIN CHUTE #2 MULTIPLIER**

Coin conversion rate for #2. (How many coins 1 inserted coin counts for)

*NOTE: When (A) COIN CHUTE TYPE is set to "COMMON," COIN CHUTE #1 and COIN CHUTE #2 can be set separately.*

**(F) BONUS ADDER**

Use of a bonus coin.

NO BONUS ADDER	No bonus coin given
2 COINS GIVE 1 EXTRA COIN	2 coins inserted successively award 1 bonus coin
3 COINS GIVE 1 EXTRA COIN	3 coins inserted successively award 1 bonus coin
4 COINS GIVE 1 EXTRA COIN	4 coins inserted successively award 1 bonus coin
5 COINS GIVE 1 EXTRA COIN	5 coins inserted successively award 1 bonus coin
6 COINS GIVE 1 EXTRA COIN	6 coins inserted successively award 1 bonus coin
7 COINS GIVE 1 EXTRA COIN	7 coins inserted successively award 1 bonus coin
8 COINS GIVE 1 EXTRA COIN	8 coins inserted successively award 1 bonus coin
9 COINS GIVE 1 EXTRA COIN	9 coins inserted successively award 1 bonus coin

**(G) COIN TO CREDIT**

The number of coins to number of credits conversion rate.

Move the cursor to EXIT and press the TEST Button to return to the COIN ASSIGNMENTS screen.

**(H) GAME COST SETTING**

Use the COIN ASSIGNMENTS GAME COST SETTING screen to set the cost (number of required credits) that the game program will use to determine if there are enough credits to play the game.

A total of 8 game costs can be defined. The game cost is defined by the BOOT ID, and when the second boot recognizes the game, the game cost defined by the BOOT ID will be displayed.

If the game is not recognized, the default game cost will be displayed.

■ **GAME COST SETTING Screen**

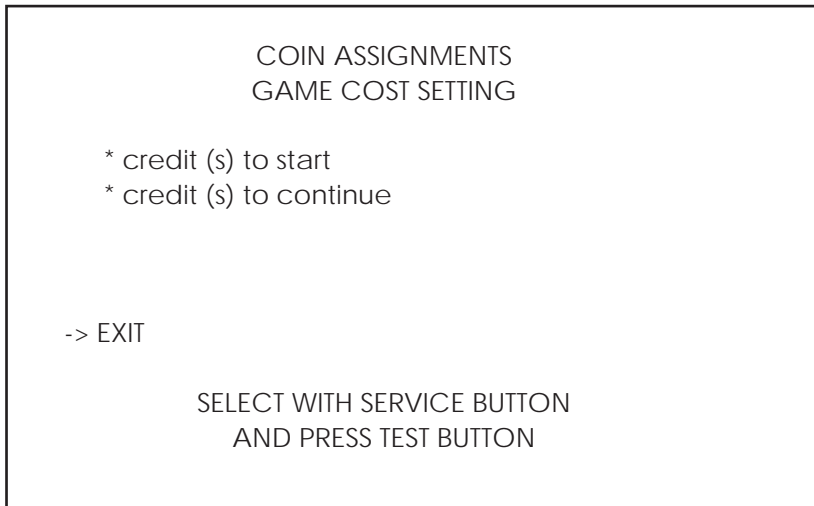

*NOTE: The screen display will vary depending on the game that is installed. The figure above is one example.*

Move the cursor to EXIT and press the TEST Button to return to the COIN ASSIGNMENTS screen.

**(I) EXIT**

Move the cursor to EXIT and press the TEST Button to return to the SYSTEM TEST MODE screen.

## 9-10 CLOCK SETTINGS

Use CLOCK SETTING to set the date and time.

Use the SERVICE Button to move the cursor to the category that you wish to change and press the TEST Button to increase that value. Holding the TEST Button down will make the value continuously increase.

### ■ CLOCK SETTING Screen

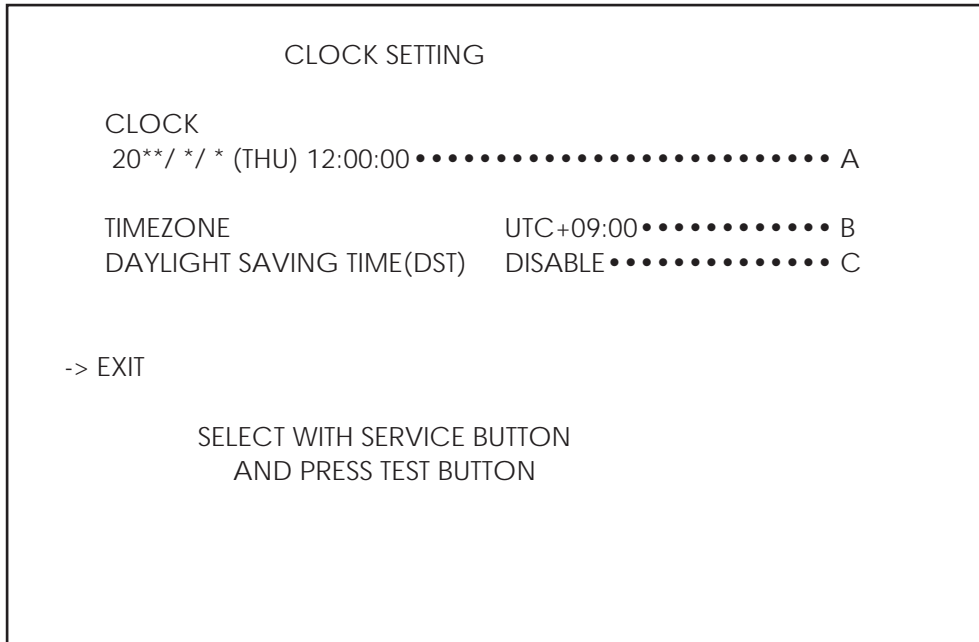

[DAYLIGHT SAVING TIME (DST): DISABLE]

#### (A) CLOCK

Displays the current time and date.

The time and date can be changed by selecting CLOCK.

Use the SERVICE Button to move the underline to the item you want to change and press the TEST Button to change the value.

If you select EXIT and press the TEST Button after changing the setting, you will be asked whether you really want to make the changes.

Select “YES” to change the value or “NO” to leave it as it is, and press the TEST Button.

Games connected to the network will adjust the time automatically.

Exercise caution as the game may become unplayable if the time is changed.

#### (B) TIMEZONE

Displays the time zone setting. If the machine is not available for ALL.Net, it is not displayed.

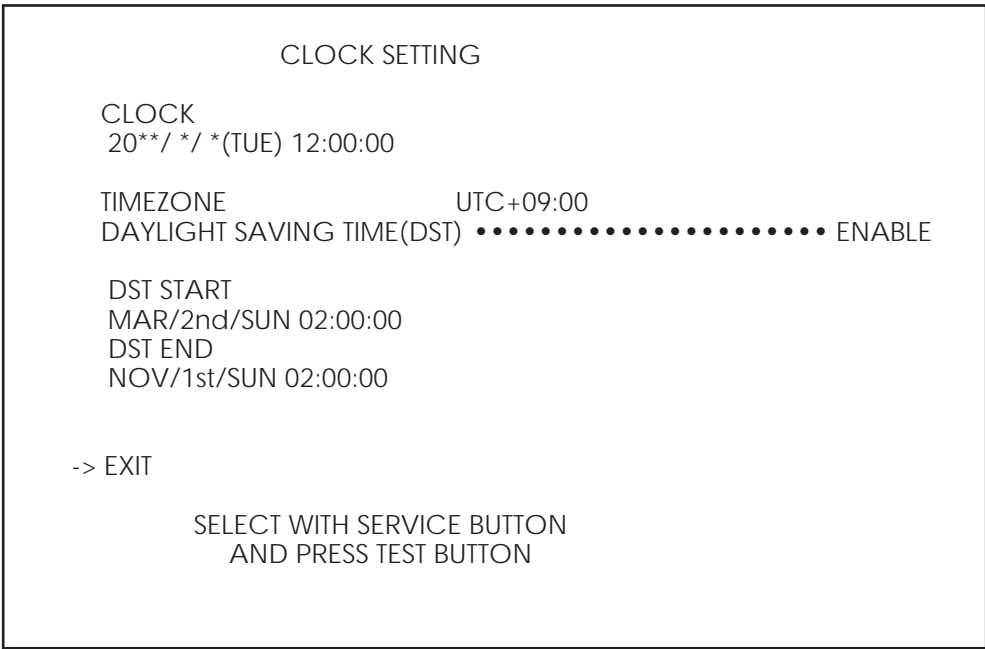

[DAYLIGHT SAVING TIME (DST): ENABLE]

**(C) DAYLIGHT SAVING TIME (DST)**

Displays the daylight saving time setting.

If set to ENABLE, you can specify when to start and end daylight saving time.

Move the cursor to EXIT and press the TEST Button to return to the SYSTEM TEST MODE screen.



## 9-11 NETWORK TEST

Use NETWORK SETTING to determine network settings or to test the network.  
There is no need to alter these settings for a game that does not use a network.

### ■ NETWORK SETTING (Setting Menu) Screen

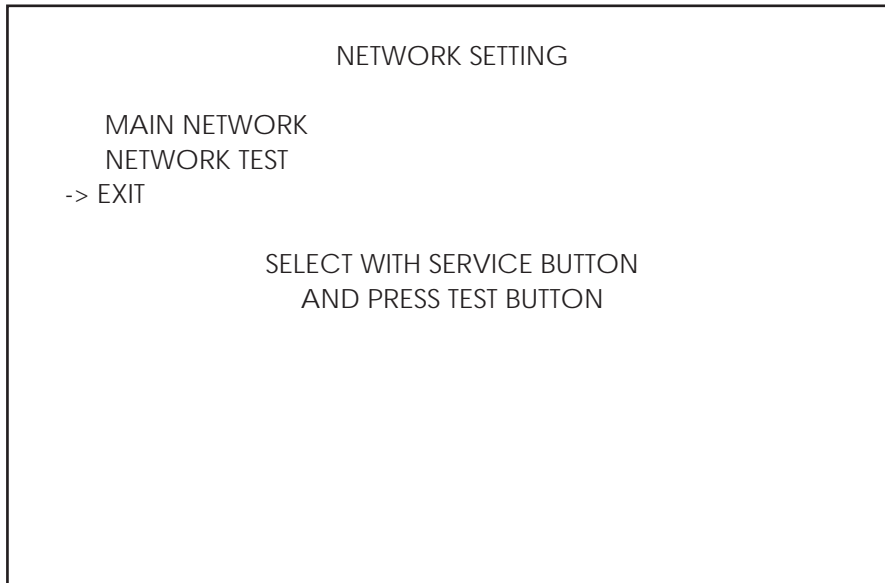

The following information is displayed on this screen.

MAIN NETWORK	Performs a network setting.
NETWORK TEST	Performs a network test.

Move the cursor to EXIT and press the TEST Button to return to the SYSTEM TEST MODE screen.

When using a hub for connecting a number of cabinets in a network, please change the IP addresses accordingly.

IP (192.168.88.XX)      XX indicating the cabinet number. i.e. 192.168.88.01 for cabinet 1. 192.168.88.02 for cabinet 2 and so on up to a total of 8 cabinets.

### **STOP** IMPORTANT

- **Do not connect any other device into the same hub as the linked cabinet. Doing so will cause networking problems between cabinets**



**NETWORK TEST**

Check the network connection.

The test will begin as soon as this screen is displayed. The machine cannot be operated until the test is finished.

■ **NETWORK TEST Screen**

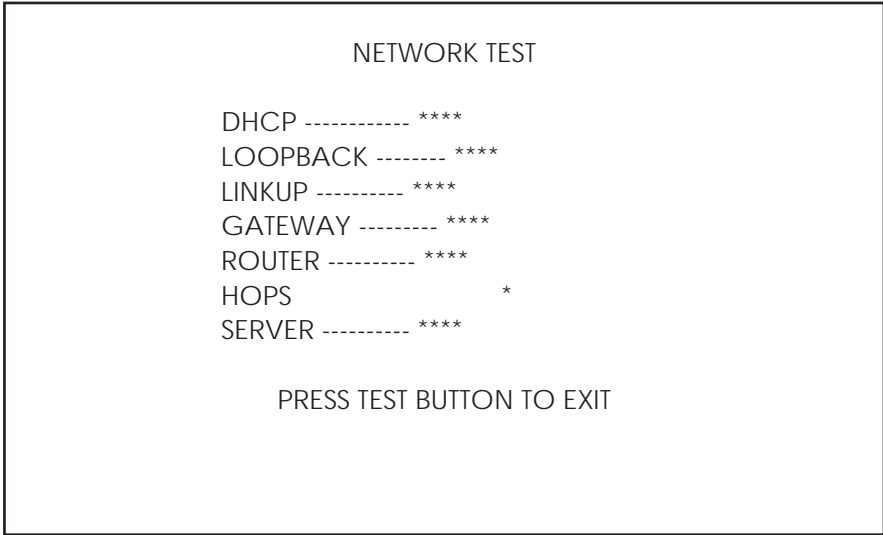

The following information is displayed on this screen.

DHCP	Status of communication settings acquisition when DHCP is set to ENABLE.
LOOPBACK	RINGWIDE network function operation status.
LINKUP	LAN cable connection status.
GATEWAY	Status of connection with title router, etc.
ROUTER	Status of connection with ALL.Net router.
HOPS	Number of router connections to ALL.Net router.
SERVER	Status of connection with ALL.Net server.

The status of determining items is as listed in the table below:

CHECK	Indicates that the item is currently being checked.
GOOD	Indicates that the item is functioning normally.
BAD	Indicates that the item is not functioning normally. (Damaged, incorrect settings, etc.)
N/A	Indicates that the item has not been checked. (Prerequisites have not been met, etc.)

Press the TEST Button to return to the NETWORK SETTING (Setting Menu) screen.

**9-12 EXIT**

Exit the Test Mode.

## 10 CONTROLLER UNIT(S)

### WARNING

- When working with the product, be sure to turn the power off. Working with the power on may cause an electric shock or short circuit.
- Be careful not to damage the wires. Damaged wires may cause an electric shock, short circuit or present a risk of fire.
- Exercise due caution in performing soldering work. If soldering iron is handled carelessly, there could be fires or burns.

### CAUTION

- When fastening plastic parts, be careful not to tighten screws or nuts excessively. If these are tightened to excess, parts could be damaged, resulting in injuries from fragments, etc.
- After the unit has been disassembled and reassembled again, check carefully that the unit has been reassembled correctly.
- Be sure to inspect the outer covers on both gear and hand brake units.
- Assemble so that there is no gap between the L and R covers. If there is a gap or rattling, the players could get fingers or hands caught, resulting in injury.

### IMPORTANT

- Once the product has been disassembled, use slack preventive agent (product No. : 090-0012-N). Coat screws with suitable amounts of this agent and then tighten them. If this agent is not used, the product might start rattling or come apart.
- Use the slack preventive agent prescribed in these instructions. If any other agent is used, there could be chemical changes that inhibit the use of screws and part surfaces could be damaged.
- Be careful not to damage or lose small parts or screws.
- When a part has been replaced, be sure to always make adjustments and check conditions in Test Mode.

## STOP IMPORTANT

Be sure to perform volume's move value setting in the INPUT ASSIGNMENTS in the Game Test Mode after replacing or adjusting the Volume.

In cases the Steering operability is poor and the adjustment of VOLUME SETTING in the TEST mode has no effect, the causes may be the volume gear's mesh failure and or volume malfunctioning.

Adjust volume gear mesh or replace the volume as per the following procedure.

In this product, when the steering wheel is moved fully left/right, if the volume shaft is rotating within the movable range, the volume is not feared to be damaged.

Secure the volume in the manner the volume shaft is oriented as shown and the gears are appropriately engaged when the steering wheel is in the centering position allowing the car to go straight forward.

### 10-1 REMOVING THE CONTROL PANEL

A 5 mm hexagonal wrench is required for the following procedure.

- 1 Turn off the power.
- 2 Remove the 4 hexagon socket button head screws from both sides of the Control Panel's front part.
- 3 Remove the 2 hexagon socket button head screws from underside of the Control Panel.
- 4 Wiring connectors are connected inside the Control Panel. Be careful not to damage any of the wiring, and carefully pull out the Control Panel.
- 5 Unplug the wiring connectors.

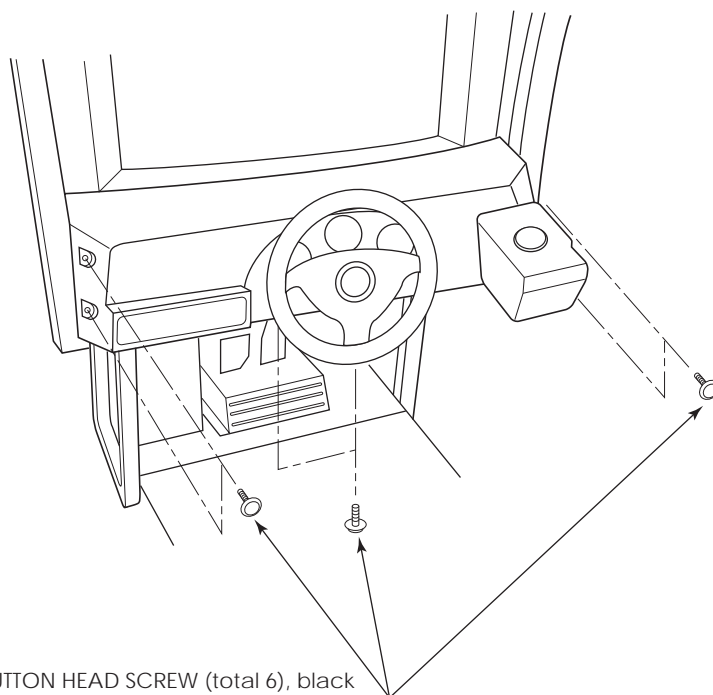

HEXAGON SOCKET BUTTON HEAD SCREW (total 6), black  
M8x30, flat and spring washers used

10-1 FIG. 01

## 10-2 ADJUSTING/REPLACING THE VOLUME

### ADJUSTMENT PROCEDURE

- 1** Loosen the 2 screws that secure the VR Bracket and move the VR Bracket to adjust the angle and condition of the gear alignment.
- 2** Keeping the handle straight, align the gears so that the direction of the D Cut side of the V.R. Shaft matches that shown in the diagram.
- 3** Tighten the 2 screws and secure the VR Bracket.
- 4** Check to make sure the value on the Input Test screen is within the range  $80H \pm 8H$  when the steering unit is in the straight position.

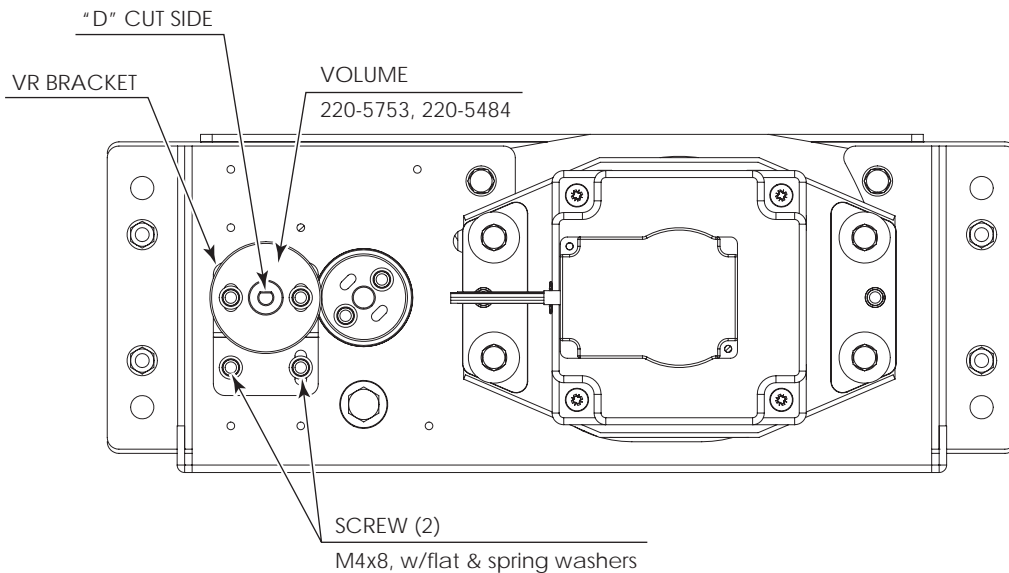

10-2 FIG. 01

## REPLACEMENT PROCEDURE

This procedure requires the following tools: Phillips screwdriver for the M4 screws, 1.5 mm hexagonal wrench, 11-12 mm monkey wrench, nipper, cutter, wire stripper, soldering iron, industrial dryer and heat-shrinkable tube.

- 1 Remove the connectors.
- 2 Remove the 2 screws securing the VR Bracket and remove the entire Bracket and V.R.
- 3 Loosen the 2 hexagon socket screws on the Gear Holder and remove the Gear Holder.
- 4 Remove the nut securing the VR Bracket, then separate the Volume from the VR Bracket and replace it.
- 5 Check to make sure the value on the Input Test screen is within the range  $80H \pm 8H$  when the steering unit is in the straight position.

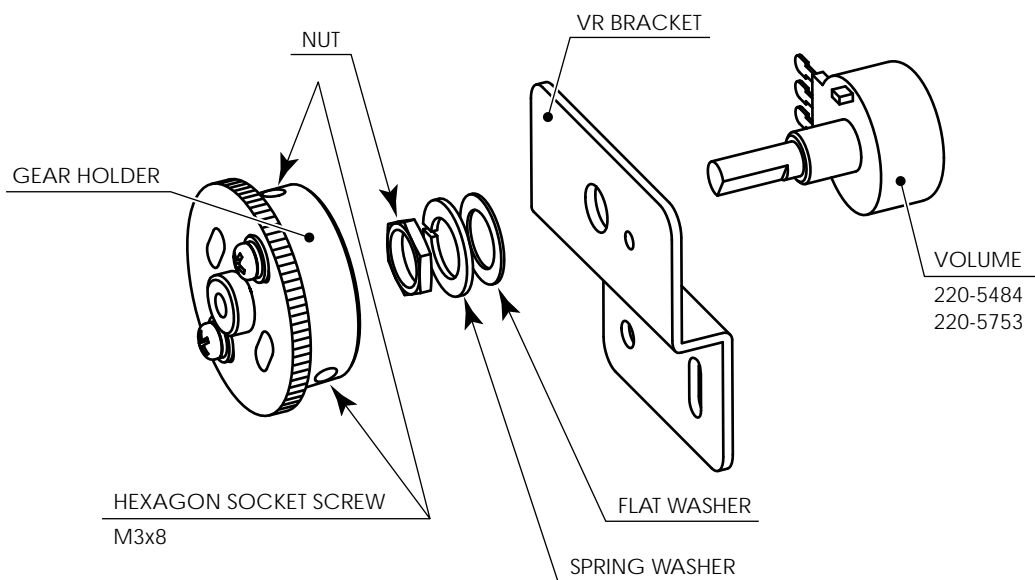

10-2 FIG. 02

## 10-3 GREASING

### STOP IMPORTANT

- **Be sure to use the designated grease. Using undesignated grease can cause parts damage.**
- **Do not apply grease to locations other than as specified. Doing so may create a risk of operational problems and deterioration of parts.**
- **The designated periods for greasing serve only as a guide. Whenever there are squeaks or other anomalies, apply grease at designated locations.**

Use spray grease once every three months to grease up the gear mesh portion of the constituent parts.  
Use "Grease Mate" (part number 090-0066) for the spray grease.

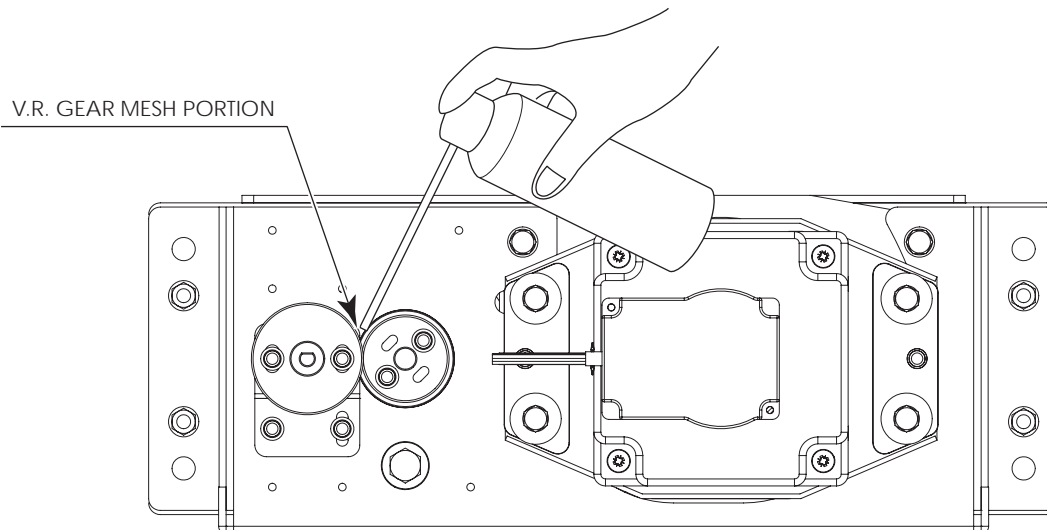

10-3 FIG. 01



## 10-4 START BUTTON ASSY

### WARNING

- When working with the product, be sure to turn the power off. Working with the power on may cause an electric shock or short circuit.
- Be careful not to damage the wires. Damaged wires may cause an electric shock, short circuit or present a risk of fire.

If the start switch input does not function correctly on the INPUT TEST screen, the switch may need to be replaced. To carry out this maintenance, you must first remove the start button unit. For this task, you will need a tamper proof wrench (for M4 screws),

### Start Button Plate Removal

- 1 Turn the power OFF
- 2 Using the M4 tamper proof wrench remove the four tamper proof screws, 1 located in each of the corner of the Start Button Plate.
- 3 Gently lift out the Button Plate to reveal the wiring harness, locate the plug connecting it to the Control panel and remove the connection. The Button and Plate can now be extracted.

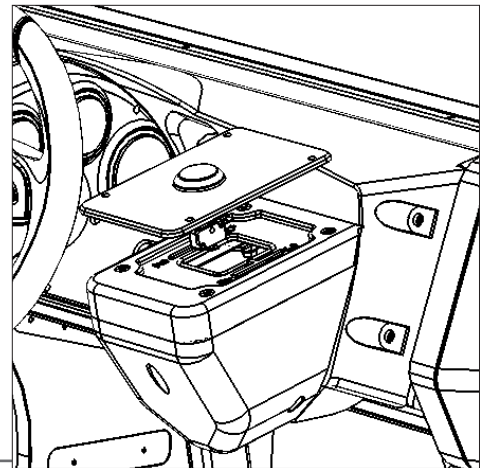

- 4 When re-installing the Start Button and Plate follow the above instructions in the reverse order. At this time ensure that the orientation of the Button Plate is correct before securing.
- 5 After the Re-installation of the Button Plate and Start Button, be sure to check the INPUT TEST in the Game Test mode to determine it's correct operation.

## Start Button/switch replacement

Follow the instructions below to change the microswitch.

- 1 Unscrew and remove the START BUTTON PLATE as explained on the previous page.

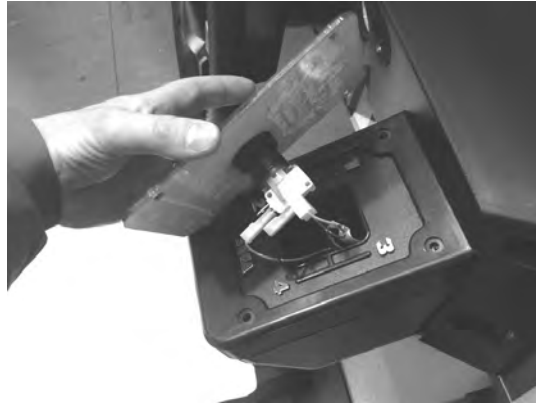

- 2 Remove the microswitch by unclipping it from the Lamp Housing



- 3 Remove the wiring harness from the old microswitch and re-attach it to the replacement switch in the same manner

- 4 Clip the Microswitch back into the lamp house making sure that it is fully in place.

- 5 The unit is now ready to be refitted into the Control Panel, to do this follow the instructions in reverse order

## 10-5 BRAKE AND ACCELERATOR UNIT

### WARNING

When working with the product, be sure to turn the power off. Working with the power on may cause an electric shock or short circuit. However, the unit must be switched on when using test mode. Do not touch any part of the unit except those areas indicated.

Be careful not to damage the wires. Damaged wires may cause an electric shock, short circuit or present a risk of fire.

This work should be performed by site maintenance personnel or other skilled professionals. **Work performed by non-technical personnel can cause a severe accident such as an electric shock.**

To prevent accidents while working or while operating the product after it has been installed, be sure not to conduct any procedures other than those given in this manual. There are cases in which procedures not covered in this manual require special tools and skills.

**If a procedure not given in this manual is required, request service from the office given in this manual or from the point of purchase.**

### IMPORTANT

**Be sure to perform volume's move value setting in the Input Test in the Game Test Mode after replacing or adjusting the Volume.**

If the accelerator or brake pedals are not functioning correctly, you may need to adjust the positioning of the volume or replace it with a new one. In addition, you should apply grease to the gear contacts and spring parts once every three months.

When the accelerator pedal is not being pressed, the accelerator volume should have a value of 30H or less. When the pedal is being pressed, the value should be C0H or greater.

When the brake pedal is not being pressed, the value should be 35H or less. When the pedal is being pressed, it should be D0H or more. You can view these values in test mode. Note that the unit must be switched on to use test mode. Do not touch any part of the unit except those areas indicated when the unit is switch on, as there is a danger of electrical shock or short-circuit.

For this task, you will need a Phillips-head screwdriver (for M4, M5 screws).

## Adjusting Procedure

- 1 On the accelerator and brake pedal unit, remove the two truss screws and lift off the front cover.

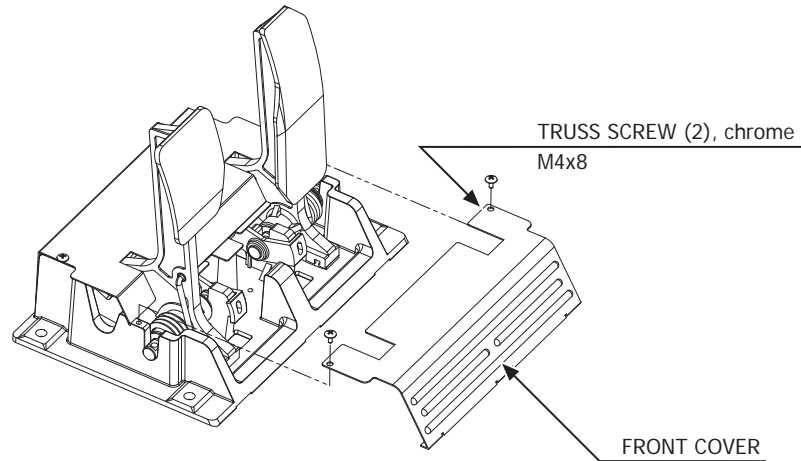

10-3 FIG. 01

- 2 Loosen the single screw that secures the potentiobase, and move the base to adjust the volume values.

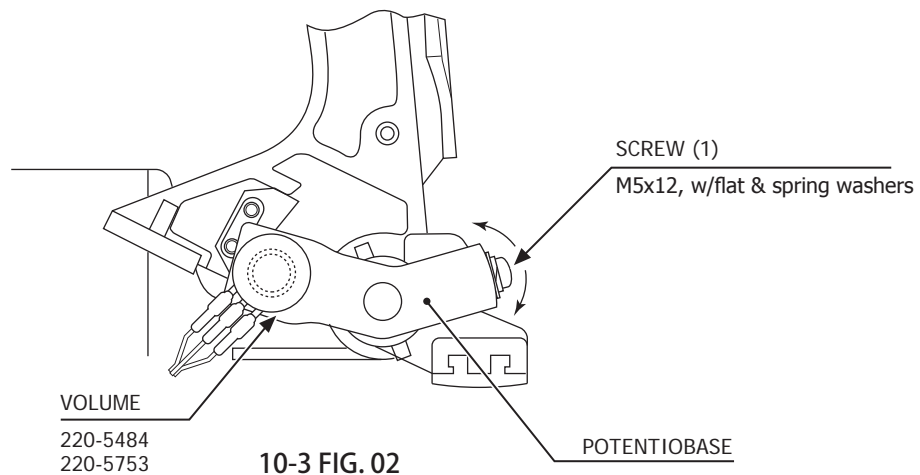

10-3 FIG. 02

- 3 Secure the potentiobase.
- 4 Configure the volume values on the INPUT ASSIGNMENTS screen in Game Test Mode.
- 5 Check that the values change smoothly in response to pedal input.

## Replacing the Volume

- 1 Switch off the unit.
- 2 Remove the two screws and lift off the potentiometer cover.

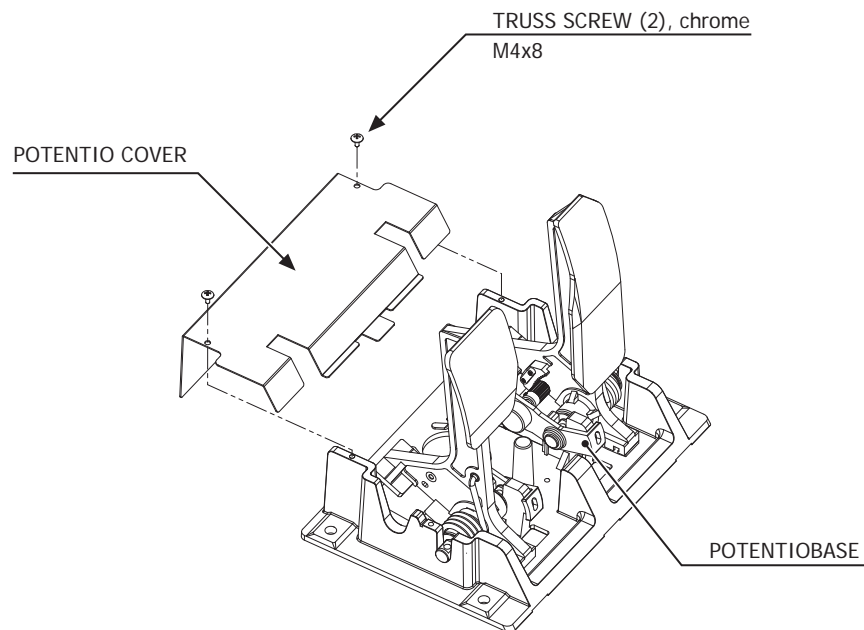

10-3-1 FIG. 01

- 3 Detach the connector from the volume to be replaced.
- 4 Remove the single screw that secures the potentiometer base. (see 10-31 FIG. 02).
- 5 Without detaching the volume, remove the potentiometer base. (see 10-31 FIG. 03).
- 6 Remove the base and gear from the volume, and replace it.
- 7 After replacement, configure the volume as described above in "Adjusting Procedure"
- 8 When you have finished, check that the values change smoothly in response to pedal input.

## Greasing

### **STOP** IMPORTANT

Use only the specified grease. Using any other kind of grease can result in damage to parts.

Once every three months, you should apply grease to the gear contacts and spring parts. Use Grease Mate-brand spray grease (Part No.: 090-0066).

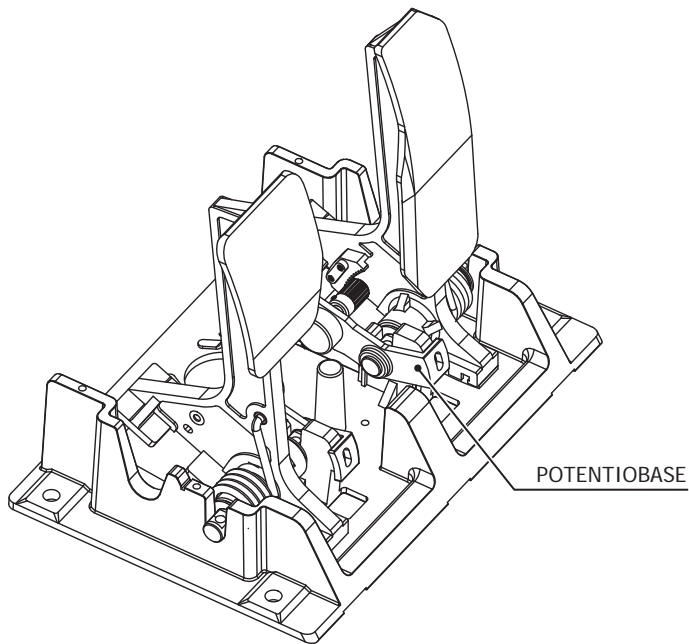

10-3-2 FIG. 01

# 11 GRAPHICS DISPLAY

## 11-1 SAFETY PRECAUTIONS WHEN HANDLING THE MONITOR

### WARNING

#### Responding to breakdown or abnormality

- If smoke or a strange odor appears, immediately unplug the power cable from the power source.

Continuing to use the product may cause a fire or an electric shock. Ensure that smoke is no longer emitted, and contact the point of purchase.

- If nothing displays on the screen, immediately unplug the power cable from the power source.

Continuing to use the product may cause a fire or an electric shock. Contact the point of purchase and request an inspection.

- If water or a foreign object enters the monitor's interior, immediately unplug the power cable from the power source.

Continuing to use the product may cause a fire or an electric shock. Contact the point of purchase and request an inspection.

- If the monitor is dropped or the cabinet is damaged, immediately unplug the power cable from the power source.

Continuing to use the product may cause a fire or an electric shock. Contact the point of purchase and request an inspection.

#### During operation

- Do not repair, reconstruct, or disassemble the monitor.

The monitor's interior contains high voltage parts. A fire or an electric shock could result.

For inspections, adjustments, and repair of the monitor's interior, request work from the point of purchase.

- Do not insert foreign objects.

If metal objects or flammable materials such as paper are inserted into the interior through ventilation openings or other apertures, an electric shock could result.

- In the event of a thunder storm, do not touch the product or the power cable. An electric shock could result.

- Make sure to perform appropriate adjustments. Do not operate the product when the screen is flickering, distorted, or experiencing other abnormalities. Images from an improperly adjusted screen could cause players and other customers to experience dizziness, headaches, and other ailments.

## 11-2 CLEANING THE SCREEN SURFACE

### CAUTION

- Use a soft, dry cloth (flannel-type) to wipe away dirt. Do not use materials such as coarse mesh gauze.
- Alcohol (ethanol) is the recommended solvent for removing dirt. When using a cleaning agent, follow the precautions below.
  - Dilute neutral cleaning agents for home use with water. Soak a soft cloth in the solution, and wring it thoroughly before wiping the screen.
  - Do not use abrasive cleaning agents or powders, or cleaning agents containing bleach.
  - Do not use alkaline cleaning agents such as glass cleaners, or solvents such as thinners.
- Do not scrub or scratch the screen surface with abrasive materials such as brushes or scrub brushes.

**CLEAN THE SCREEN DAILY.**



## 11-3 ADJUSTMENT METHOD

### **STOP** IMPORTANT

All adjustment values are set accurately at the time of shipping from the factory. Do not readjust these values needlessly or apply adjustments not specified in this manual. The display may not appear properly if the values are incorrect.

### CONTROL - ADJUSTMENT PROCEDURE

This sections explains basic control procedures for making adjustments using the buttons on the 'Monitor Adjustment Board'

This Adjustment Board, and the Monitor Power Supply are located behind the Rear Door.

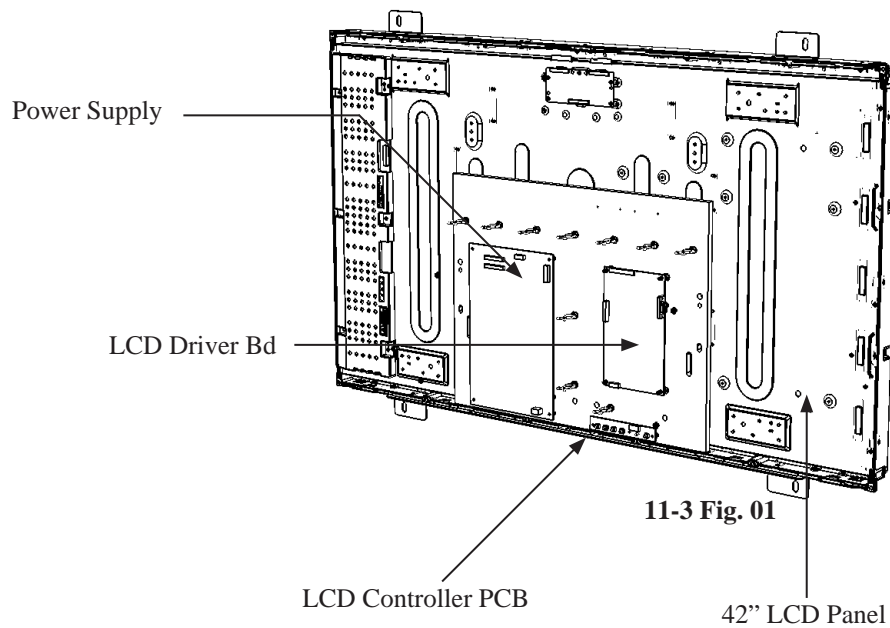

## Button Names and Functions

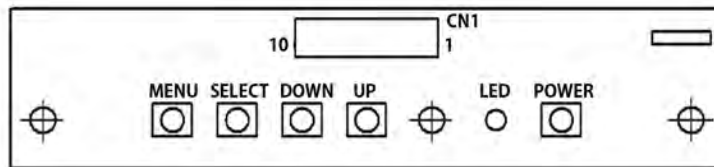

11-3 Fig. 02

**MENU:** Turn the Picture Menu display ON and OFF.

**SELECT:** Gains entry to the Item selected in the menu. (Highlights in Yellow when selected)  
Exits the Item adjustment. Any changes made during this operation are actioned.

**DOWN:** Moves the cursor (Black Bar) down to select a menu item.  
Decrease the value of, or change, a selected menu item.

**UP:** Move the cursor (Black Bar) up to select a menu item.  
Increase the value of, or change, a selected menu item.

**LED:** LED illuminates green: Monitor is operating.  
LED flashes red: Power is off.

**POWER:** Turns the LCD Display ON and OFF. (Usually, it's not necessary to operate.)

## On-Screen Display (OSD)

Press the MENU Button while the OSD is not displayed to bring up the Picture Menu.  
 On the Picture Menu, it is possible to perform various screen adjustments.



11-3 Fig. 03

Use the UP and DOWN Buttons to move the 'Black Bar' to the item you want to adjust.  
 After selecting the desired item, pressing the SELECT Button will extend the MENU Screen and allow adjustments to be changed.

Within each item, press the SELECT Button to exit the adjustment screen. The adjustment values at this time will be saved simultaneously.



11-3 Fig. 04

The current options are set at :

CSM	-	6500K
Brightness	-	100
Contrast	-	50

## On-Screen Display (OSD) <continued>



11-3 Fig. 05

### Available Settings

CSM (Selects Operation Mode)  
Selection available - 6500K - 9300K - USER

BRIGHTNESS (Adjust Brightness)  
Adjust screen Brightness. - Values: 0 - 100  
(0" being the darkest setting, and "100" being the brightest)

CONTRAST (Adjust Contrast)  
Adjust Contrast level. - Values: 0 - 100  
(0" having the least amount of difference between light and dark, and "100" having the most)

## 12 COIN HANDLING

### Handling the Coin Jam

If the coin is not rejected when the REJECT button is pressed, open the coin chute door and open the selector gate. After removing the jammed coin, put a normal coin in and check to see that the selector correctly functions.

12

COIN HANDLING

### 12-1 CLEANING THE COIN SELECTOR

#### STOP IMPORTANT

- Remove and clean smears by using a soft cloth dipped in water or diluted chemical detergent and then squeezed dry.
- Never apply machine oil, etc. to the Coin Selector.
- After cleaning the Coin Selector, insert a regular coin in the normal working status and ensure that the selector correctly functions.

The Coin Selector should be cleaned once every 3 months.  
When cleaning, follow the procedure below:

- 1 Turn the power for the machine OFF. Open the Coin Chute Door
- 2 Remove the Coin Selector from the Coin Chute Door
- 3 Open the gate and dust off by using a soft brush (Small soft Paint Brush, etc.)

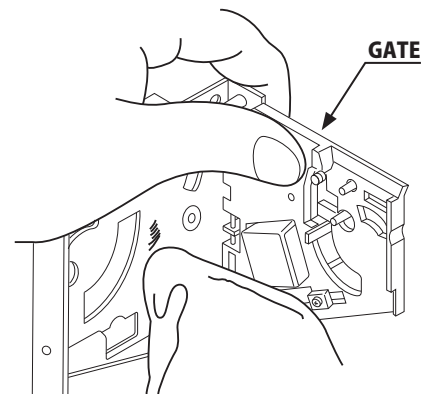

12-1 FIG 1

## CLEANING THE COIN SELECTOR <continued>

**1** Remove and clean smears by using a soft cloth dipped in water or diluted chemical detergent and then squeezed dry.

**2** Remove the CRADLE.. When removing the retaining ring (E ring) be very careful so as not to bend the rotary shaft.

**3** Remove stain from the rotary shaft and shaft receiving portions by wiping off with a soft cloth, etc.

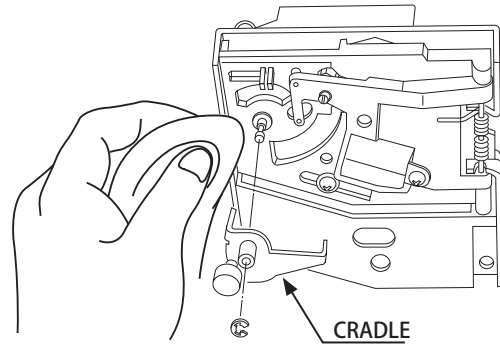

12-1 FIG 2

**4** After wiping off as per previous step, further apply a dry cloth to completely dry the Coin Selector.

### Coin Insertion Test

Once every month, when performing the Coin SW Test, simultaneously check the following:

Does the Coin Meter count satisfactorily?

Does the coin drop into the cashbox correctly?

Is the coin rejected when inserted while keeping the REJECT Button pressed down?

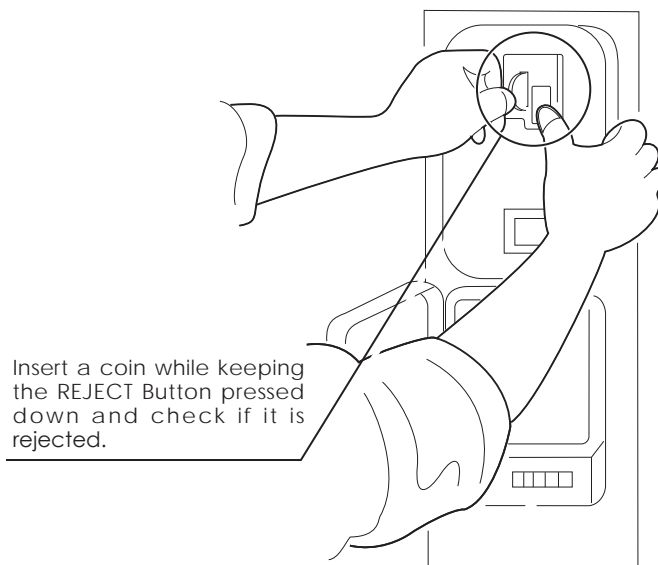

12-1 FIG 3

## 12-2 ADJUSTING THE PRICE OF PLAY

This product comes equipped with a Money Controls SR3 Coin Acceptor. To adjust the price of play ALL credit setting are adjusted via the EXCEL CREDIT BOARD.

### IMPORTANT!

The CREDIT SETTINGS within the SYSTEM TEST MODE must be set to 1 coin 1 credit to allow the CREDIT BOARD to function correctly.

The VTS BD has a built in Credit Board. This is controlled by 2 DIL Switches. These allow the operator to select the price of play, type of coin acceptor and region.

### ExcelBoard

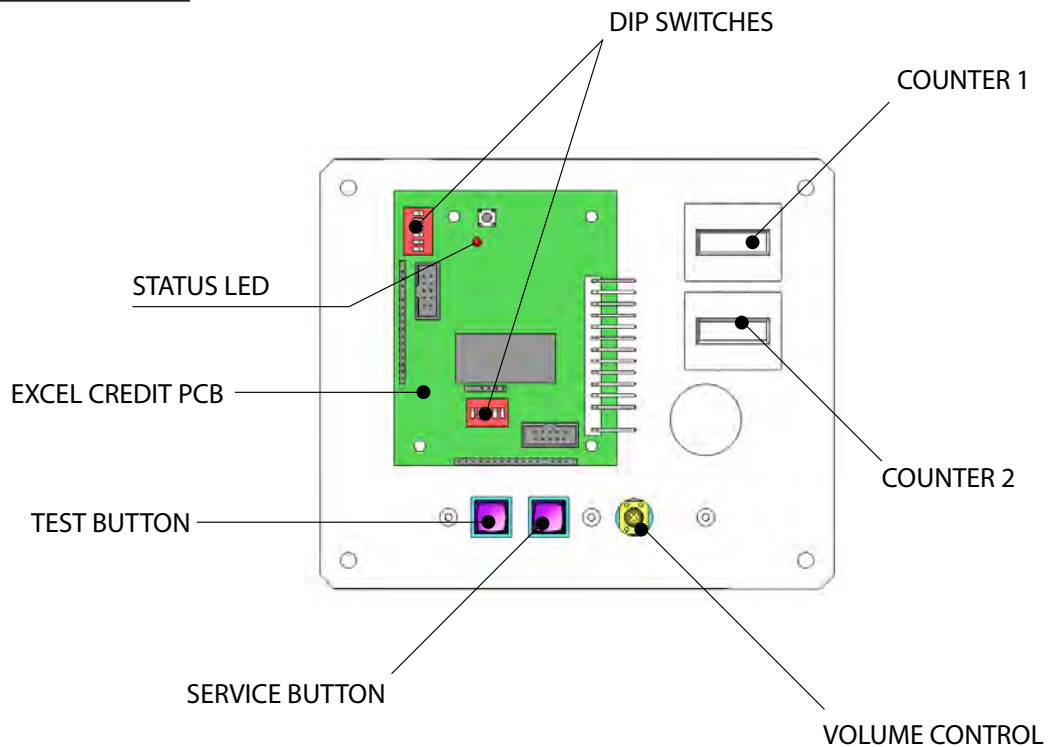

### DIL SW3 (Regional Settings)

Adjust these switches to specify the type of Coin Acceptor used and currency.

Default = SW1&SW2 ON - SR3 in parallel mode, Sterling.

### TEST BUTTON

Provides access to the TEST MENU when pressed.

### SERVICE BUTTON

Provides a SERVICE CREDIT when pressed

### Status LED

Flashes when functioning.

### CHANNEL 1

To Coin Acceptor (SR3 TYPE.)

### DIL SW1 (credit settings)

Adjust to required price of pay.

### VOL CONTROL

MAIN VOLUME ADJUSTMENT (FRONT SPEAKERS)

Country	Setting	Switch 3 Setting						Credit Board Mode Settings Switch 3											
		SW1	SW2	SW3	SW4	SW5	SW6	Coin Validator Programming						C120/SR3 Only					
		COIN1	COIN2	COIN3	COIN4	COIN5	COIN6	COIN7	COIN8	COIN9	COIN10	COIN11	COIN12						
UK	Coin Controls C220 Parallel	OFF	OFF	OFF	OFF		£1	50p new	20p	10p	-	50p old	-	-					
UK	Coin Controls C220 Binary	ON	OFF	OFF	OFF		£1	50p new	20p	10p	-	50p old	-	£2					
UK	Coin Controls C220 Binary	OFF	ON	OFF	OFF		£1	50p new	20p	10p	-	£2	-	50p old					
UK	Coin Controls SR3 Parallel	ON	ON	OFF	OFF		£1	50p new	20p	10p	-	£2	-	50p old					
UK	Coin Controls SR3 Parallel	OFF	OFF	ON	OFF		£2	£1	50p new	20p	10p	-	-	50p old					
Euro	Coin Controls SR3 Parallel	ON	OFF	ON	OFF		£2	£1	50p new	20p	10p	-	-	50p old					
UK	Mars MEMS 111 Parallel	ON	OFF	ON	OFF		£1	£2	20p	10p	50p new	50p old							
UK	NRI Parallel	OFF	ON	ON	OFF		10p	20p	50p	£1	£2	-							
Belgium	Parallel	ON	ON	ON	OFF		-	50Bfr	20Bfr	5Bfr									
Holland	Parallel	OFF	OFF	OFF	ON		-	5NLG	2.5NLG	1NLG									
Austria	SR3 Parallel	ON	OFF	OFF	ON		20Sch	10Sch	5Sch	1Sch									
Spain	Coin Controls C220 Binary	OFF	ON	OFF	ON		500Pta	200Pta	100Pta	50Pta	25Pta	200Pt old	50Pta old	25Pta old					
Spain	SR3/NRI Parallel	ON	ON	OFF	ON		500Pta	200Pta	100Pta	50Pta	25Pta	200Pt old	50Pta old	200Pta old					
Spain	Coin Controls C220 Parallel	OFF	OFF	ON	ON		100Pta	50Pta new	-	25Pta new	-	50Pta old	-	25Pta old					
Portugal Euro	Parallel	ON	OFF	ON	ON		200Es	100Es	50Es	-	-	-	-	-					
	TBA				OFF		TBA												
	Channels				ON		TBA												
							OFF Direct Mode												
							ON 2 channel Mode												

**Please Note**  
The credit board automatically sets the validator for parallel and binary operation through an output on pin 8 of the 17 way pinstrip. For the feature to work it is necessary for the validator interconnecting cable to include at wire at this position

Note: These switch settings are under constant review and may change due to world currency updates.

Set SW 1 according to the option settings found in the relevant Price of Play Settings Table on the following pages.

Set SW 3 on the VTS /Excel board as shown in the table above corresponding to the country required.

REGIONAL AND ACCEPTOR SETTINGS (SW3)



STERLING PRICE OF PLAY SETTINGS (SW1)

	Price	Bonus					DIL Switch 1				
							1	2	3	4	5
1	10p	50p = 5 plays	£1 = 10 plays	£2 = 20 plays		OFF	OFF	OFF	OFF	OFF	
2	10p	50p = 6 plays @ 8.33p per play	£1 = 12 plays @ 8.33p per play	£2 = 24 plays @ 8.33p per play		ON	OFF	OFF	OFF	OFF	
3	20p	50p = 2.5 plays	£1 = 5 plays	£2 = 10 plays		OFF	ON	OFF	OFF	OFF	
4	20p	50p = 3 plays @ 16.66p per play	£1 = 6 plays @ 16.66p per play	£2 = 12 plays @ 16.66p per play		ON	ON	OFF	OFF	OFF	
5	30p	50p = 1.66 plays	£1 = 3.33 plays	£2 = 6.66 plays		OFF	OFF	ON	OFF	OFF	
6	30p	50p = 1.66 plays	£1 = 4 plays @ 25p per play	£2 = 8 plays @ 25p per play		ON	OFF	ON	OFF	OFF	
7	30p	50p = 2 plays @ 25p per play	£1 = 4 plays @ 25p per play	£2 = 8 plays @ 25p per play		OFF	ON	ON	OFF	OFF	
8	30p	50p = 2 plays @ 25p per play	£1 = 3 plays @ 33.33p per play	£2 = 6 plays @ 33.33p per play		ON	ON	ON	OFF	OFF	
9	40p	50p = 1.25 plays	£1 = 2.5 plays	£2 = 5 plays		OFF	OFF	OFF	ON	OFF	
10	40p	50p = 1.25 plays	£1 = 3 plays @ 33.3p per play	£2 = 6 plays @ 33.3p per play		ON	OFF	OFF	ON	OFF	
11	50p	50p = 1 play	£1 = 2 plays	£2 = 4 plays		OFF	ON	OFF	ON	OFF	
12	50p	50p = 1 play	£1 = 3 plays @ 33.3p per play	£2 = 6 plays @ 33.3p per play		ON	ON	OFF	ON	OFF	
13	50p	50p = 1 play	£1 = 2 plays	£2 = 5 plays @ 40p per play		OFF	OFF	ON	ON	OFF	
14	60p	50p = 0.83 play	£1 = 1.66 plays	£2 = 3.33 plays		ON	OFF	ON	ON	OFF	
15	60p	50p = 0.83 play	£1 = 2 plays @ 50p per play	£2 = 4 plays @ 50p per play		OFF	ON	ON	ON	OFF	
16	80p	50p = 0.62 play	£1 = 1.25 plays	£2 = 2.5 plays		ON	ON	ON	ON	OFF	
17	80p	£1 = 1.25 plays	£1.50 = 2 plays @ 75p per play	£2 = 2.5 plays		OFF	OFF	OFF	OFF	ON	
18	£1	2x50p = 1 play	£1 = 1 play	£2 = 2 plays		ON	OFF	OFF	OFF	ON	
19	£1	2x50p = 1 play	£1 = 1 play	£2 = 3 plays @ 66.6p per play		OFF	ON	OFF	OFF	ON	
20	£1	2x50p = 1 play	£2 = 2 plays	£4 = 5 plays @ 80p per play		ON	ON	OFF	OFF	ON	
21	£1.50	3x50p = 1 play	£1 = 0.66 plays	£3 = 2 plays		OFF	OFF	ON	OFF	ON	
22	£1.50	3x 50p = 1 play	£1 = 0.66 plays	£2 = 2 plays @ £1 per play		ON	OFF	ON	OFF	ON	
23	£2	4x 50p = 1 play	£1 = 0.5 play	£2 = 1 play		OFF	ON	ON	OFF	ON	
24	£2	4x 50p = 1 play	£1 = 0.5 play	£5 = 3 plays @ £1.66 per play		ON	ON	ON	OFF	ON	
25	£3	6x50p = 1 play	£1.50 = 0.5 play	£3 = 1 play		OFF	OFF	OFF	ON	ON	
26	£3	6x50p = 1 play	£1.50 = 0.5 play	£5 = 2 plays @ £2.50 per play		ON	OFF	OFF	ON	ON	
27	£5	£1 = 0.2 play	£5 = 1 play	£10 = 2 plays		OFF	ON	OFF	ON	ON	
28	£5	£1 = 0.2 play	£5 = 1 play	£10 = 3 plays @ £3.33p per play		ON	ON	OFF	ON	ON	
29	£7.50	£5 = 0.66 play	£10 = 1.33 plays	£15 = 2 plays		OFF	OFF	ON	ON	ON	
30	£7.50	£5 = 0.66 play	£10 = 1.33 plays	£10 = 2 plays @ £5 per play		ON	OFF	ON	ON	ON	
31	£10	£10 = 1 play	£20 = 2 play	£30 = 3 play		OFF	ON	ON	ON	ON	
32		Free Play					ON	ON	ON	ON	ON

EURO PRICE OF PLAY SETTINGS (SW1)

	Price	Bonus					DIL Switch 1				
							1	2	3	4	5
1	10¢	50¢ = 5 plays	€1 = 10 plays	€2 = 20 plays	OFF	OFF	OFF	OFF	OFF	OFF	
2	10¢	50¢ = 6 plays @ 8.33p per play	€1 = 12 plays @ 8.33¢ per play	€2 = 24 plays @ 8.33¢ per play	ON	OFF	OFF	OFF	OFF	OFF	
3	20¢	50¢ = 2.5 plays	€1 = 5 plays	€2 = 10 plays	OFF	ON	OFF	OFF	OFF	OFF	
4	20¢	50¢ = 3 plays @ 16.66¢ per play	€1 = 6 plays @ 16.66¢ per play	€2 = 12 plays @ 16.66¢ per play	ON	ON	OFF	OFF	OFF	OFF	
5	30¢	50¢ = 1.66 plays	€1 = 3.33 plays	€2 = 6.66 plays	OFF	OFF	ON	OFF	OFF	OFF	
6	30¢	50¢ = 1.66 plays	€1 = 4 plays @ 25¢ per play	€2 = 8 plays @ 25¢ per play	ON	OFF	ON	OFF	OFF	OFF	
7	30¢	50¢ = 2 plays @ 25¢ per play	€1 = 4 plays @ 25¢ per play	€2 = 8 plays @ 25¢ per play	OFF	ON	ON	OFF	OFF	OFF	
8	30¢	50¢ = 2 plays @ 25¢ per play	€1 = 3 plays @ 33.33¢ per play	€2 = 6 plays @ 33.33¢ per play	ON	ON	ON	OFF	OFF	OFF	
9	40¢	50¢ = 1.25 plays	€1 = 2.5 plays	€2 = 5 plays	OFF	OFF	OFF	ON	OFF	OFF	
10	40¢	50¢ = 1.25 plays	€1 = 3 plays @ 33.33¢ per play	€2 = 6 plays @ 33.33¢ per play	ON	OFF	OFF	OFF	ON	OFF	
11	50¢	50¢ = 1 play	€1 = 2 plays	€2 = 4 plays	OFF	ON	ON	OFF	ON	OFF	
12	50¢	50¢ = 1 play	€1 = 3 plays @ 33.33¢ per play	€2 = 6 plays @ 33.33¢ per play	ON	ON	OFF	ON	ON	OFF	
13	50¢	50¢ = 1 play	€1 = 2 plays	€2 = 5 plays @ 40¢ per play	OFF	OFF	ON	ON	ON	OFF	
14	60¢	50¢ = 0.83 play	€1 = 1.66 plays	€2 = 3.33 plays	ON	OFF	ON	ON	ON	OFF	
15	60¢	50¢ = 0.83 play	€1 = 2 plays @ 50¢ per play	€2 = 4 plays @ 50¢ per play	OFF	ON	ON	ON	ON	OFF	
16	80¢	50¢ = 0.62 play	€1 = 1.25 plays	€2 = 2.5 plays	ON	ON	ON	ON	ON	OFF	
17	80¢	€1 = 1.25 plays	€1.50 = 2 plays @ 75¢ per play	€2 = 2.5 plays	OFF	OFF	OFF	OFF	OFF	ON	
18	€1	2x50¢ = 1 play	€1 = 1 play	€2 = 2 plays	ON	OFF	OFF	OFF	OFF	ON	
19	€1	2x50¢ = 1 play	€1 = 1 play	€2 = 3 plays @ 66.6¢ per play	OFF	ON	OFF	OFF	OFF	ON	
20	€1	2x50¢ = 1 play	€2 = 2 plays	€4 = 5 plays @ 80¢ per play	ON	ON	OFF	OFF	OFF	ON	
21	€1.50	3x50¢ = 1 play	€1 = 0.66 plays	€3 = 2 plays	OFF	OFF	ON	OFF	OFF	ON	
22	€1.50	3x 50¢ = 1 play	€1 = 0.66 plays	€2 = 2 plays @ €1 per play	ON	OFF	ON	OFF	OFF	ON	
23	€2	4x 50¢ = 1 play	€1 = 0.5 play	€2 = 1 play	OFF	ON	ON	ON	OFF	ON	
24	€2	4x 50¢ = 1 play	€1 = 0.5 play	€5 = 3 plays @ €1.66 per play	ON	ON	ON	ON	OFF	ON	
25	€3	6x50¢ = 1 play	€1.50 = 0.5 play	€3 = 1 play	OFF	OFF	OFF	OFF	ON	ON	
26	€3	6x50¢ = 1 play	€1.50 = 0.5 play	€5 = 2 plays @ €2.50 per play	ON	OFF	OFF	OFF	ON	ON	
27	€5	€1 = 0.2 play	€5 = 1 play	€10 = 2 plays	OFF	ON	OFF	OFF	ON	ON	
28	€5	€1 = 0.2 play	€5 = 1 play	€10 = 3 plays @ 3.33¢ per play	ON	ON	OFF	OFF	ON	ON	
29	€7.50	€5 = 0.66 play	€10 = 1.33 plays	€15 = 2 plays	OFF	OFF	ON	ON	ON	ON	
30	€7.50	€5 = 0.66 play	€10 = 1.33 plays	€10 = 2 plays @ €5 per play	ON	OFF	ON	ON	ON	ON	
31	€10	€10 = 1 play	€20 = 2 play	€30 = 3 play	OFF	ON	ON	ON	ON	ON	
32		Free Play					ON	ON	ON	ON	ON

## 13 LAMPS AND LIGHTING

### ⚠ WARNING

- When working with the product, be sure to turn the power off. Working with the power on may cause an electric shock or short circuit.
- You may get burned by hot lamps. Pay full attention to the lamps when performing the work.
- Be sure to use lamps of the designated rating. Using lamps of undesignated rating can cause a fire or malfunctioning.
- There is the danger of short circuits or smoke generation due to deterioration of insulation in lighting fixtures resulting from age deterioration. Check for anomalies such as the following: Does it smell like something is burning? Is there socket discoloration? Are any lamps being replaced frequently? Do lamps not go on properly?

### ⚠ CAUTION

The Coin Door Lamp utilises a 12v 1.2w Wedge Bulb. It is important that you replace this bulb or any other bulb of that of the same voltage and rating. Failing to observe this caution may result in PCB failure or possible fire hazard.

### 13-1 COIN DOOR LAMP

Step 1. Open the Coin Door and locate the Lamp Housing directly behind the Coin Insert Bezel.  Lamp Housing

Step 2. Hold the Lamp Housing firmly between your index finger and thumb and gently pull upwards. Do Not try to remove the Lamp Housing whilst holding the bulb as the bulb may break causing injury.

Step 3. Once the Lamp Housing has been removed, carefully hold the bulb between your fingers and pull the Lamp Housing away.

Do not twist either bulb or Lamp Housing whilst removing the bulb as this may cause damage to both bulb and or Housing.

Type: Wedge Bulb - 12v, 1.2w

Step 4. Simply push-fit a replacement bulb of the same type and follow these steps in reverse to refit.



## 13-2 LED LIGHTING - BILLBOARD

### WARNING

THIS WORK ON TOP OF THE CABINET, SHOULD NOT BE UNDERTAKEN WITHOUT THE USE OF A SUITABLE STEP OR FOOTSTOOL.

### WARNING

MAKE SURE THAT THE MAIN SUPPLY VOLTAGE TO THE MACHINE IS SWITCHED OFF BEFORE ATTEMPTING TO CARRY OUT THIS WORK

**1** The Billboard lighting is located inside the back section of the Billboard Base, before attempting to change the LED, TURN THE POWER OFF.

**2** To gain access to the LED STRIP, extract the eleven (11) fixing screws which hold the Billboard Title Panel in place and remove.

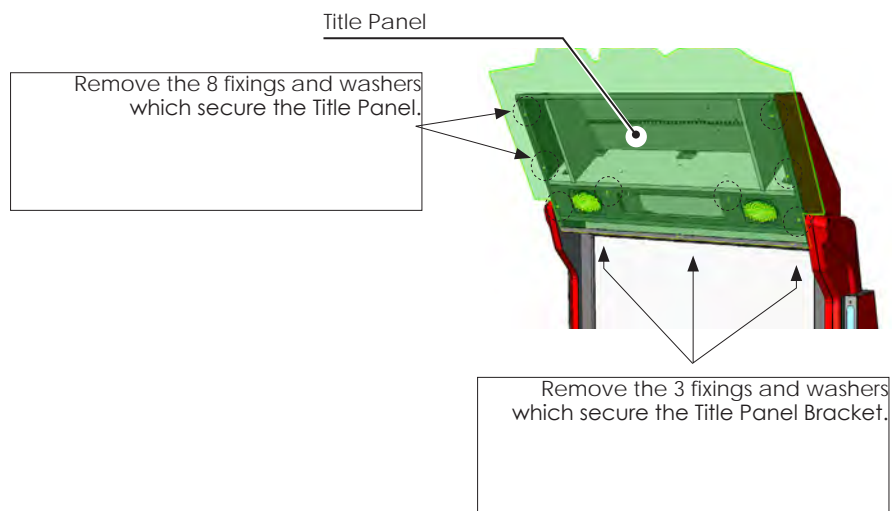

**3** Carefully remove the Billboard Plate to reveal the LED strip..

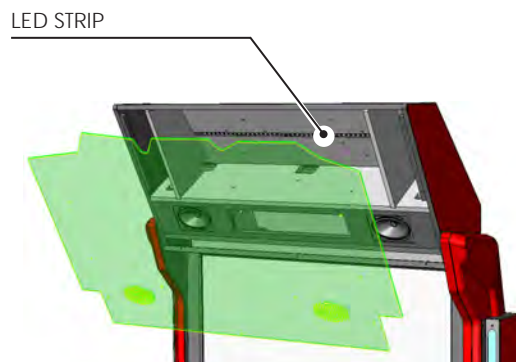

- 
- 3 The LED STRIP is self adhesive. Before removal, unclip the connector at the R/H edge. Carefully peel off the LED STRIP from the back of the BILLBOARD.

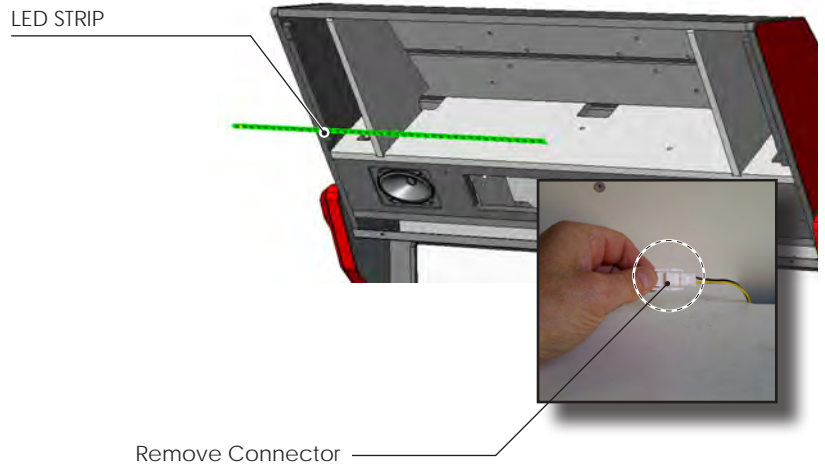

- 
- 4 Replace the LED strip with a new one of the same type and re-assemble the Billboard in the reverse order.

## 13-3 FEATURE LED LOWER

### WARNING

THIS WORK ON TOP OF THE CABINET, SHOULD NOT BE UNDERTAKEN WITHOUT THE USE OF A SUITABLE STEP OR FOOTSTOOL.

### WARNING

MAKE SURE THAT THE MAIN SUPPLY VOLTAGE TO THE MACHINE IS SWITCHED OFF BEFORE ATTEMPTING TO CARRY OUT THIS WORK

- 1 The K.O Feature Lamp is a strip of bright white LED's mounted on a self adhesive strip.
- 2 To gain access to the Feature LED, remove the BILLBOARD PLATE as described in the previous section.



- 3 Unclip the LED cable clamp at the end of the LED strip and remove.

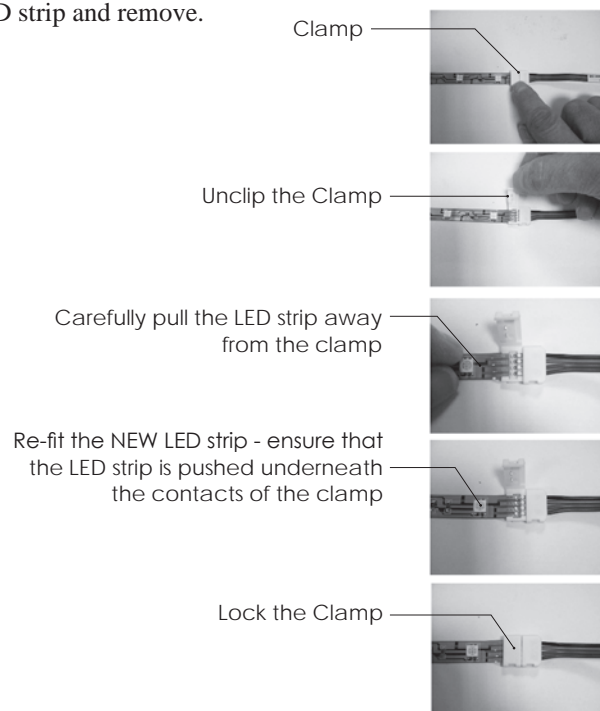

- 
- 4 Adhere the LED strip back into location. TEST the LED strip in OUTPUT test before refitting the BILLBOARD Plate.

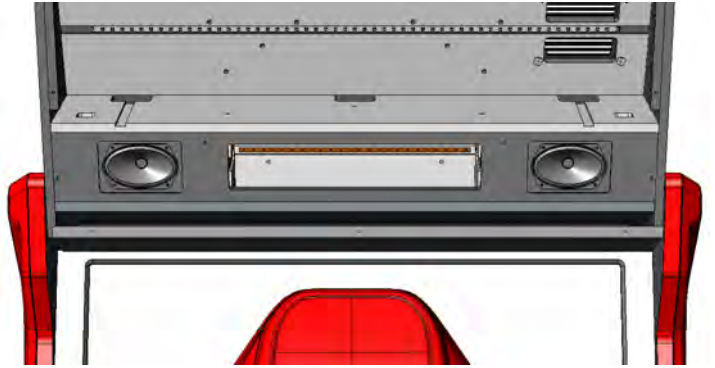

- 
- 5 Refit the BILLBOARD plate following the instructions of the previous section in reverse order.

## 13-4 FEATURE LED SIDES

### WARNING

THIS WORK ON TOP OF THE CABINET, SHOULD NOT BE UNDERTAKEN WITHOUT THE USE OF A SUITABLE STEP OR FOOTSTOOL.

### WARNING

MAKE SURE THAT THE MAIN SUPPLY VOLTAGE TO THE MACHINE IS SWITCHED OFF BEFORE ATTEMPTING TO CARRY OUT THIS WORK

- 1 The K.O Feature Lamps are strips of bright white LED's mounted on a self adhesive strip.
- 2 To gain access to the Feature LED, remove the BILLBOARD PLATE as described in the previous sections.
- 3 For easy access to the SIDE FEATURE LIGHTS, remove the inner sections of the BILLBOARD BOX by unscrewing the single fixing at the top of the cabinet.

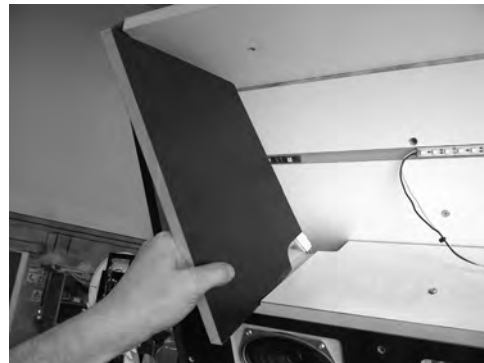

- 4 Carefully pull the harness up through the recess in the Billboard Box to reveal the connector and disconnect from the main cabinet.

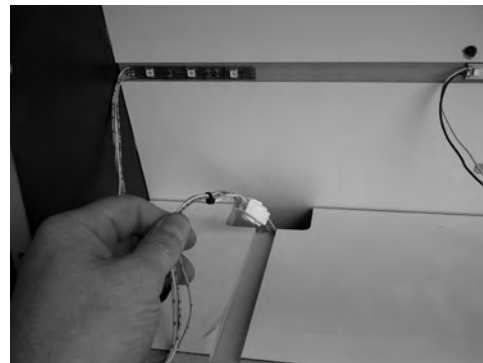



---

5 Carefully peel off the adhesive LED strip.

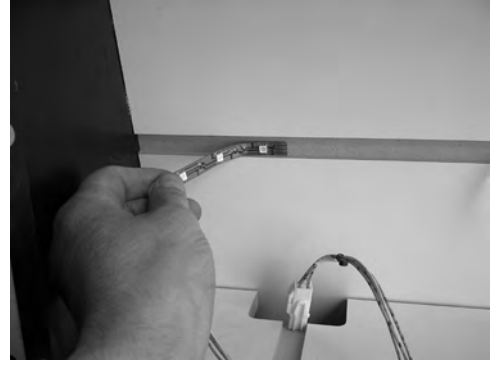

---

6 Apply the new LED adhesive strip in the same way following the instructions in reverse order.

# 14 PERIODIC INSPECTION

The items listed below require periodic check and maintenance to retain the performance of this machine and to ensure safe business operation.

When handling the controller, the player will be in direct contact with it. In order to always allow the player to enjoy the game, be sure to clean it regularly. Also, it is advisable to provide wet tissue, etc. available for player use.

## WARNING

- **Every 6 months check to see if power cords are damaged, the plug is securely inserted, dust is accumulated between the socket outlet and the power plug, etc. Using the product with accumulated dust in the interior may cause fire or electric shock.**
- **Never use a water jet, etc. to clean the inside and outside of the cabinet. If wetness occurs for any reason, do not use the product until it has completely dried.**
- **Once a year, request the office shown on this manual or the dealer from whom the product was originally purchased to perform the internal cleaning. Using the product with accumulated dust in the interior may cause fire or other accidents.**

Note that you are liable for the cost of cleaning the interior parts.

- **There is the danger of accidents involving electrical shorts circuits or fire caused by factors such as the deterioration of insulation in electrical and electronic equipment over time. Check that there are no abnormalities such as odors from burning.**

**14 TABLE 01 PERIODIC INSPECTION TABLE**

ITEMS	DESCRIPTION	PERIOD
CABINET	Confirm that adjusters contact floor	Daily
CONTROL PANEL STEERING WHEEL	Volume inspection	Monthly
	Gear alignment inspection	Every 3 months
	Greasing	Every 3 months
START BUTTON	Switch inspection	Monthly
	Greasing	Every 3 months
ACCELERATOR & BRAKE	Volume inspection	Monthly
	Gear and spring portion greasing	Every 3 months
MONITOR	Screen cleaning	Weekly
	Confirm settings	Monthly or when moving
COIN CHUTE DOOR	Coin switch inspection	Monthly
	Coin insertion test	Monthly
	Selector cleaning	Every 3 months
SEAT	Greasing to the seat rail	Every 3 months
GAME BOARD	Confirm settings	Monthly
POWER CABLES	Inspection, Cleaning	6 months
INTERIOR	Cleaning	Yearly
CABINET SURFACES	Cleaning	As appropriate

### Cleaning the Cabinet Surfaces

When the cabinet surfaces are badly soiled, remove stains with a soft cloth dipped in water or diluted (with water) chemical detergent and squeezed dry. To avoid damaging surface finish, do not use such solvents as thinner, benzine, etc. other than ethyl alcohol, or abrasives, bleaching agent and chemical dustcloth.

Some general-purpose household, kitchen and furniture cleaning products may contain strong solvents that degrade plastic components, coatings, and print. Before using any cleaning product, read the product's cautionary notes carefully and test the product first on a small area that is not highly visible.

### Seat (Greasing to Seat Rail Portion)

Move the Seat to the rear most position and apply spray greasing to the portion shown at the right once every 3 months using NOK KLUBER L60 or GREASE MATE SEGA PART No. 090-0066.

After greasing, move the Seat a few times forward and backward so as to allow the grease to be applied all over uniformly.

Be sure to wipe grease which attaches to the surfaces of the PROTECT RUBBER on the Seat Rail, or any excess grease.

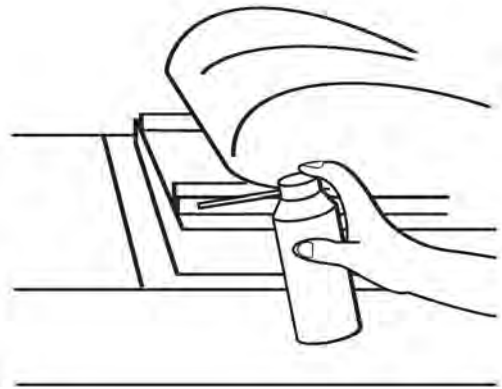

# 15 TROUBLESHOOTING

## 15-1 TROUBLESHOOTING (WHEN NO ERROR MESSAGE IS SHOWN)

### WARNING

- In order to prevent electric shock and short circuit, be sure to turn power off before performing work.
- Be careful so as not to damage wirings. Damaged wiring can cause electric shock or short circuit.
- After removing the cause of the functioning of the Circuit Protector, reinstate the Circuit Protector. Depending on the cause of the functioning, using the Circuit Protector as is without removing the cause can cause generation of heat and fire hazard.
- In the event that a problem cannot be resolved by employing the procedures listed in this Manual, be sure to request service from the office shown on this Manual or the dealer from whom the product was originally purchased. Attempts to employ procedures other than those specified in this Manual can cause electrical shock, shorting, or fire.
- In the event of a problem that is not described here, be sure to contact the office shown on this Manual or the dealer from whom the product was originally purchased. Careless attempts at repair can result in electrical shock, shorting, or fire.

If a problem occurs, first check to make sure that the wiring connectors are properly connected.

15 TABLE 01

PROBLEM	CAUSE	COUNTERMEASURES
When the main SW is turned ON, the machine is not activated.	The power is not ON.	Firmly insert the plug into the outlet.
	Incorrect power source/voltage.	Make sure that the power supply/voltage are correct.
	The Fuse on the AC Unit has blown due to momentary over current.	After eliminating the cause of overload, replace the specified rating fuse.
	The fuse of the connect board has blown due to momentary over current.	After eliminating the cause of overload, replace the specified rating fuse.
LED lamp bar inside Billboard Unit not lighting	Connector connection fault.	Check connections to the Billboard Unit.

Sound is not emitted.	Sound volume adjustment is not correct	Adjust the Switch Unit's sound adjustment volume.
	Faulty connections for various connectors	Check the connections for the game board, amp, speakers and Volume connectors
	Malfunctioning BD, amp and speaker	Perform Sound Test.
Sounds are emitted and the lamps are lit, but the screen is black.	Faulty connections for the visual signal connector or the monitor power connector	Check the connections for the monitor and game board connectors.
	Faulty LCD Display	See Chapter 11
Colors on the monitor screen are strange.	Faulty connection for the visual signal connector.	Check the visual signal connector connection and make sure it is secured properly.
	Screen adjustment is not appropriate.	Make adjustment appropriately.
The on-screen image sways and/or shrinks.	The power source and voltage are no correct.	Make sure that the power supply and voltage are correct.
Does not accept input from any switch or volume.	Faulty connector connections.	Check the connection for the I/O Board and Cabinet connector.
		Check the power for the I/O Board.
Does not accept input from the Shift Lever.	Faulty connector connections.	Check the connections for the connectors in the Control Panel and between the Control Panel and the Cabinet.
	Broken Microswitch.	Replace the Microswitch. <Microswitch 509-5704>
Steering (Servomotor) response is incorrect.	Incomplete power on check.	Power on and verify that the power on check completes properly.
	Deviation of the volume value.	Adjust the volume value in the Test Mode.
	Volume gear engagement fault.	Adjust the engagement of the gear.
	Volume malfunctioning.	Replace the volume.
	Detached wires.	Check for faulty wire connections around moving parts. When replacing wires, secure them so that they do not touch any moving parts.
No response from Steering (Servomotor).	Failure of power-on checking procedure.	Reconnect the power and complete a power-on checking procedure.
	Faulty connector connections.	Check the connections for the connectors between the Game Board and Servodriver and between the Servodriver and the Servomotor.
	Thermal element in the Servodriver is operating.	Occurs when the internal temperature reaches 70°C (158°F) and corrects automatically when the unit cools.
	Momentary overload caused a fuse on the Servodriver to blow.	Contact the company from whom the unit was purchased.

Steering (Servomotor) is weak in its force feedback	Ageing of the force feedback mechanism	Reset in the Test Mode.
Does not accept input in from the Reset Button unit.	Faulty connector or connections.	Check the connections between the I/O Board, the Cabinet and the Reset Button Unit
	Faulty Microswitch	Replace Microswitch
The accelerator or brake does not perform appropriately.	Incorrect volume setting.	Adjust the volume value in the Test Mode.
	Faulty Volume attachment or adjust gear alignment.	Adjust the volume attachment and verify in Test Mode.
	Faulty connector or connections.	Check the connections for the accelerator and brake connectors and the connectors between the accelerator, brake and cabinet.
	Failure of the volume.	Replace the volume.
Start button and View Change button input does not work and they do not flash.	Faulty connector or connections.	Check the connections for the connectors between the I/O Board, the cabinet and the control panel and those inside the control panel.
Start button and View Change button input works, but they do not flash.	Unverified settings or operation.	The Start button only flashes when Free Play is set. Check the operation in Test Mode.
	The lamp is blown.	Replace the lamp.
Failure of the network play.	Network play is wrongly set.	Reset correctly.
	Communication cables are disconnected. Communication cables are wrongly connected.	Reconnect the cables.
	Damage of communication cables.	Replace the cables. Contact the company from whom the unit was purchased.

## Replacing Fuses

### WARNING

- In case fuse replacements other than those stated in this manual are necessary, contact where you purchased the product from for inquiries regarding this matter.
- In order to prevent an electric shock, be sure to turn power off and unplug from the socket outlet before performing work by touching the internal parts of the product.
- Be careful so as not to damage wirings. Damaged wiring can cause electric shock and short circuit accidents.
- Be sure to use fuses meeting specified rating. Using fuses exceeding the specified rating can cause fire and electric shock accidents.
- After eliminating the cause of the blowing of fuse, replace the fuse. Depending on the cause of fuse blowing, continued use with the fuse as is blown can cause generation of heat and fire hazard.

Fuses are located on the following:

PD-1540UK	Assy AC Unit	(1) 5A Time Delay 20mm (1) 5A Time Delay 20mm (Spare)
838-14551-02UK	AC Distribution PCB	(2) 6.3A Time Delay 20mm

## 16 GAME BOARD

### WARNING

- When working with the product, be sure to turn the power off. Working with the power on may cause an electric shock or short circuit.
- Be careful not to damage the wires. Damaged wires may cause an electric shock, short circuit or present a risk of fire.
- Do not use this product with connectors other than those that were connected and used with the game board at the time of shipping. Do not carelessly connect wires to connectors that were not used at the time of shipping, as this may cause overheating, smoke or fire damage.

### CAUTION

In this product, setting changes are made during the test mode. The game board need not be operated. Use the game board, etc. as is with the same setting made at the time of shipment so as not to cause electric shock and malfunctioning.

### IMPORTANT

Static electricity from your body may damage some electronics devices on the IC board. Before handling the IC board, touch a grounded metallic surface so that the static electricity can be discharged.



## 16-1 GAME BD - LOCATION

16

GAME BOARD

### WARNING

- When returning the game board after making repairs or replacements, make sure that there are no errors in the connection of connectors. Erroneous connections can lead to electrical shock, short circuits or fires.
- When connecting a connector, check the direction carefully. Connectors must be connected in only one direction. If indiscriminate loads are applied in making connections, the connector or its terminal fixtures could be damaged, resulting in electrical shock, short circuits or fires.

**1** The machine is fitted with Game Board Unit(s) and several other Ancilliary Boards. The GAME BD is fitted inside the Base Box. Each machine contains the its own RING WIDE Game Unit and set of Boards allowing them to run independantly of each other. Only qualified Personnel should attempt to Service these Units and before gaining access to the machine, it should be isolated from the mains supply.

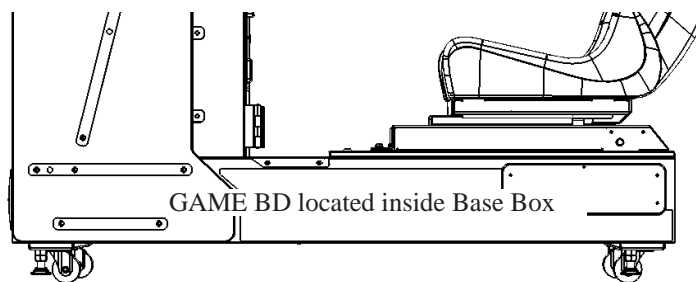

The Game Board Unit is located the foot pedals and player seat, and to gain access the following procedure should be carried out.

UnloRemove the (4) M4 Torx T20 Security Screws from the sides of the Foot Plate..

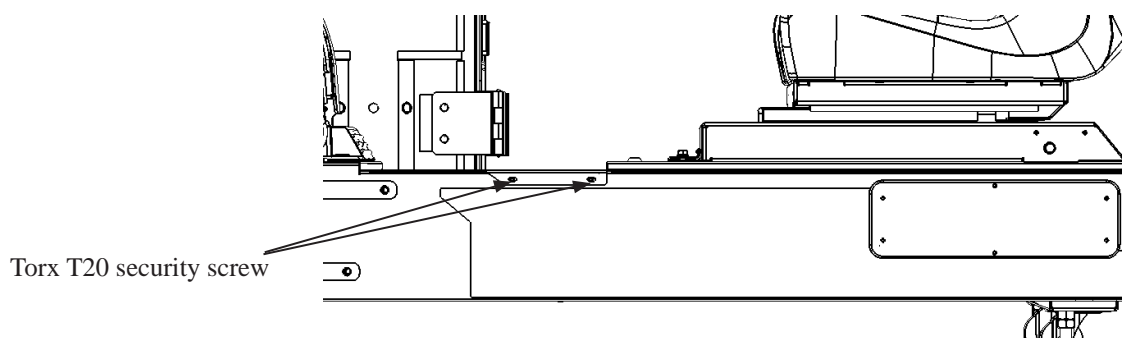

- 2** Undo and remove the (6) M6x20 HEX BLT BLK from around the seat base and the (4) M5x12 Torx T25 Security Screws

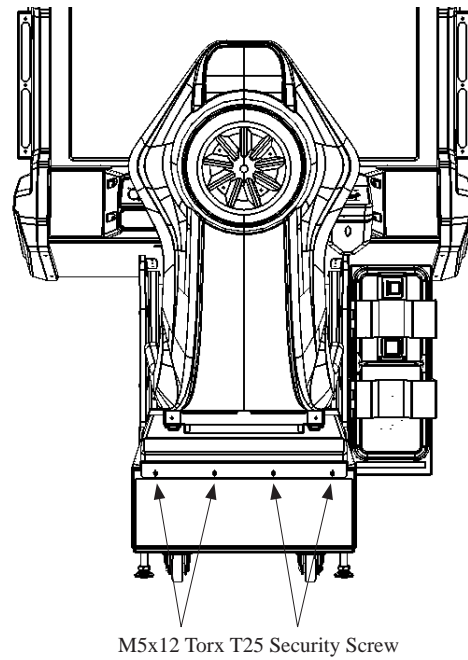
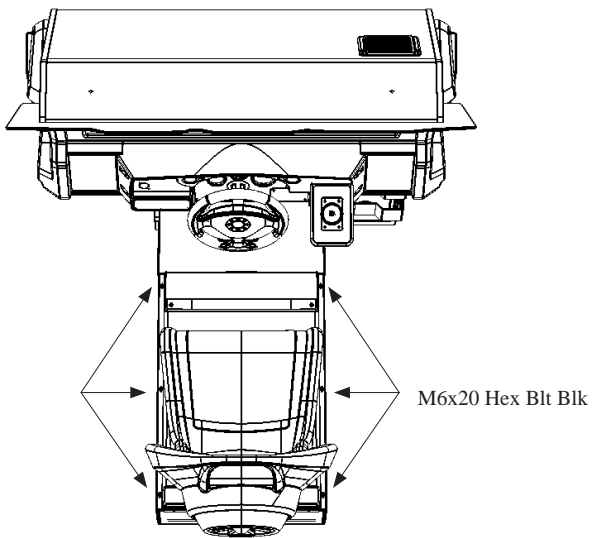

- 3** Once all fixings have been removed, lift the front edge of the Assy Seat slightly to clear the Foot Plate Tab. Once clear, carefully slide the Assy Seat back and rest in a safe position back on the Base Box.

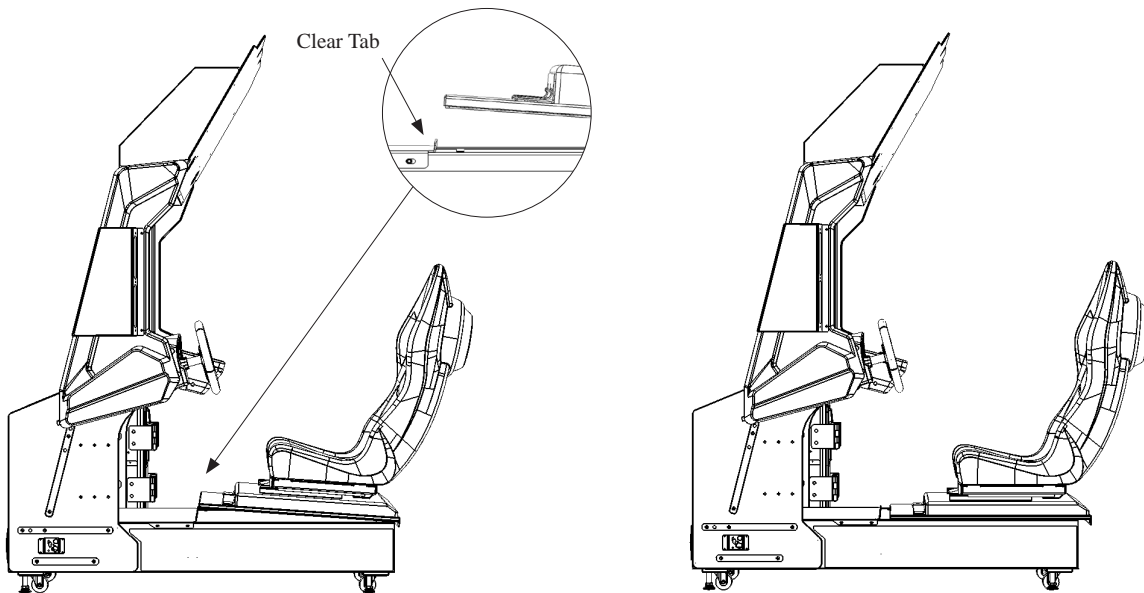

- 4** TILT the footplate in an upwards direction until the LIP on the backside of the footplate is clear of the front section of floor and REMOVE the plate.

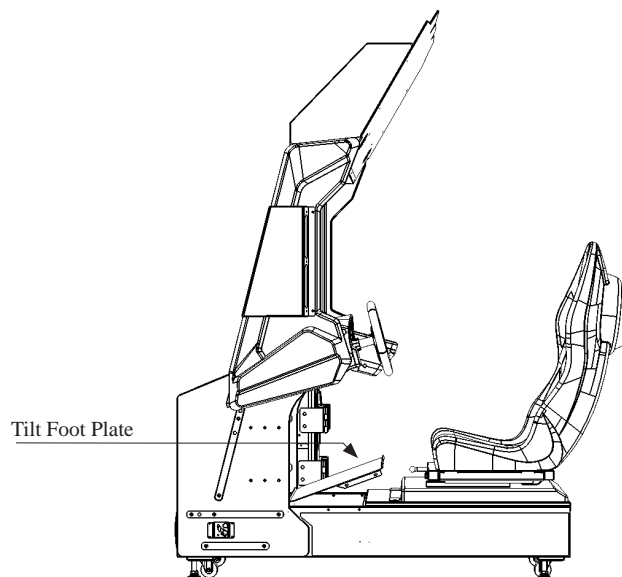

- 5** With the Foot Plate removed the Assy Game Bd is now accessible. Unscrew the (2) M4x25 PH PAN MSCR screws from the front edges of the wooden base to which the GAME BD is secured .

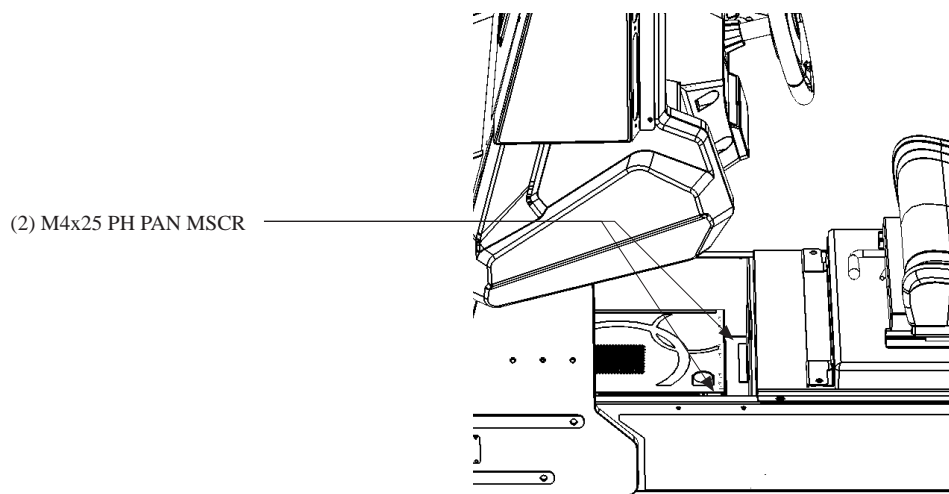

- 6** Before removal, disconnect all corresponding harnesses which prevent GAME BD removal. i.e. VGA or DVI cable, USB cable, Network cable etc.

**7** Once all harnessing has been disconnected, carefully lift the ASSY GAME BD out of the cabinet.

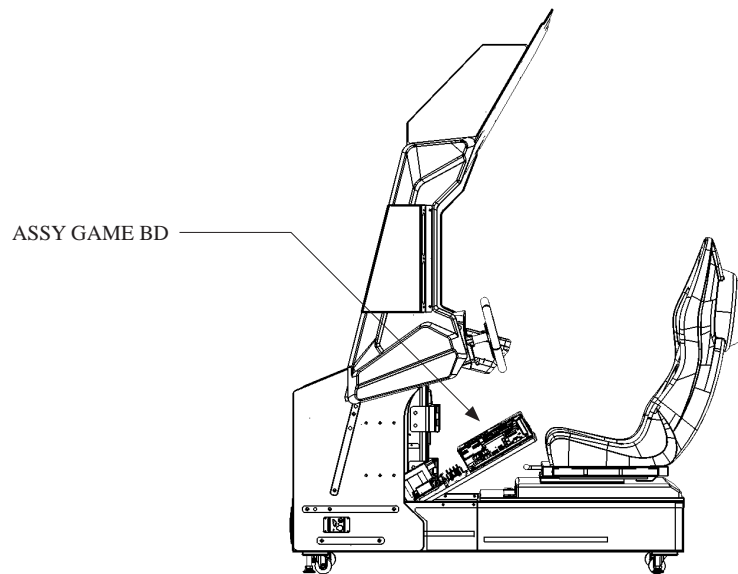

**⚠ CAUTION**

Do not open the Game Board without the express permission of SEGA. If for any reason entry has been gained into the Game Board without the permission of SEGA, then all warranty rights become void.

When returning the Game Board to SEGA for service, then please make sure that adequate packaging is used as damage in transit make occur.

## 17 COMMUNICATION PLAY

For this game, up to 8 machines can be networked together allowing up to 8 players to play simultaneously. In this instance, connecting the communication cable and adjustment to the settings for communication play will be required.

### 17-1 INSTALLATION PRECAUTIONS

#### WARNING

- Before starting to work, ensure that the Power SW is OFF. Failure to observe this can cause electric shock or short circuit.
- Use care so as not to damage wirings. Damaged wiring can cause electric shock or short circuit.
- Do not touch undesignated places. Touching places not designated can cause electric shock or short circuit.
- The work described below should be carried out by the site maintenance personnel or other qualified professional. Work carried out by personnel without the necessary skill or technology can cause accident.
- To perform work safely and avoid serious accident such as the cabinet falling down, do not perform work in places where step-like grade differences, a ditch, or slope exist.
- To prevent accidents while working or while operating the product after it has been installed, be sure not to conduct any procedures other than those given in this manual. There are cases in which procedures not covered in this manual require special tools and skills. If a procedure not given in this manual is required, request service from the office given in this manual or from the point of purchase.

#### CAUTION

- To perform work safely, be sure to secure the space corresponding to number of machines to be linked. Failure to observe this can cause accident.
- To avoid accidents, use a cable cover that will not cause patrons to trip when laying network cables in areas of heavy foot traffic.
- To prevent accidents and acts of vandalism, cover the network cables with the strongest cover possible.

Since 2 or more machines are to be linked, sufficient power corresponding to the number of machines used need to be supplied. Note that as a standard, the per machine capacity should be 7A for the 100-120V area, and 3A for the 220-240V area.

## Distance between Machines

The maximum distance between the game machines depends on the length of the cables connecting them, but make sure the units are separated from each other by at least 49 cm (19.2 in) so that players can pass between them.

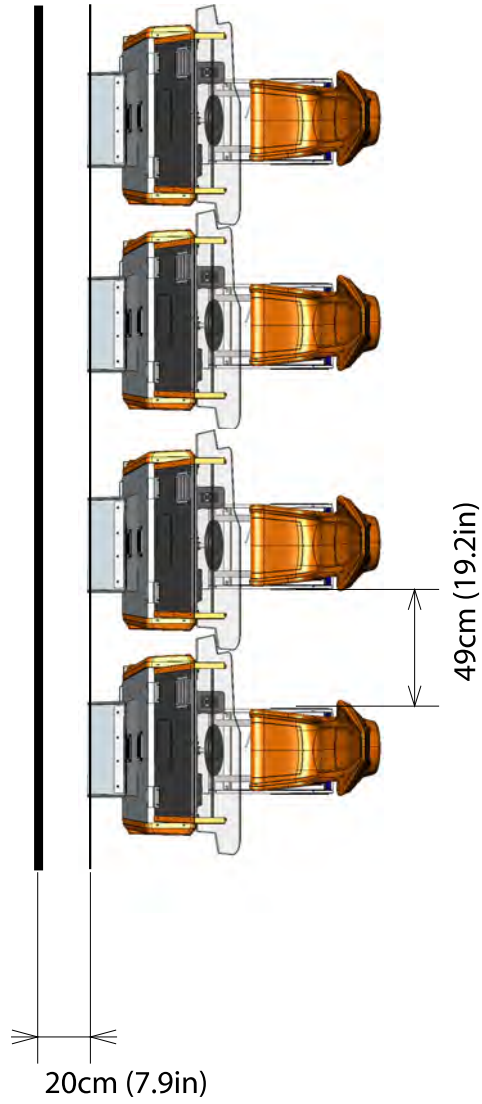

17-1 Fig 01

## 17-2 CONNECTING THE COMMUNICATION CABLE

To enable network play, the Hubs inside each of the game machines involved must be connected with network (LAN) cables. Up to a maximum of 3 machines (6 Players) can be Networked together, all that's required is to link between the Hubs of each of the machines that are to complete the 'Network'.

Do not connect LAN cables to game machines when they are not used for network play.

**1** Turn off the power and unplug the power cord from the outlet.

**2** Using Chapter 6 of this manual as reference, move the machines so that they are lined up. Leave enough space behind each Unit to allow access for a Network HUB (only required for 6 or more seats) which when located will be positioned near the Slave Cockpit of each Machine.

**3** When linking 2 seats or "Twin" cabinet, use the X-OVER Lan Cable, Pt. No. 600-7270-0200UK (Supplied). Do not use the common Lan Network Cable as this will cause a network failure or possible damage to networking components.

**4** When linking 4 or more seats a Hub Kit must be used. Please contact SEGA or your local distributors office for further technical or sales information

**5** Once the desired Network connections have been established, power on the machines and enter TEST MODE to allocate each seat a number within the NETWORK TEST.

Standard Lan/Network Cable

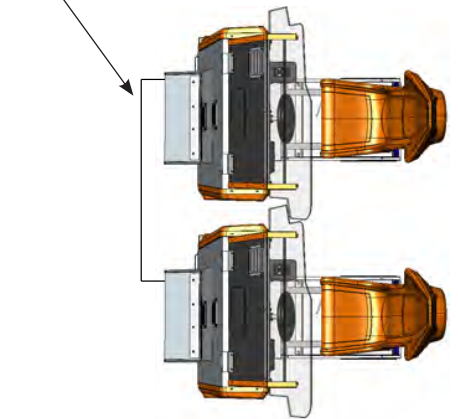

Network Kit - Not Supplied

Standard Lan Network Cable

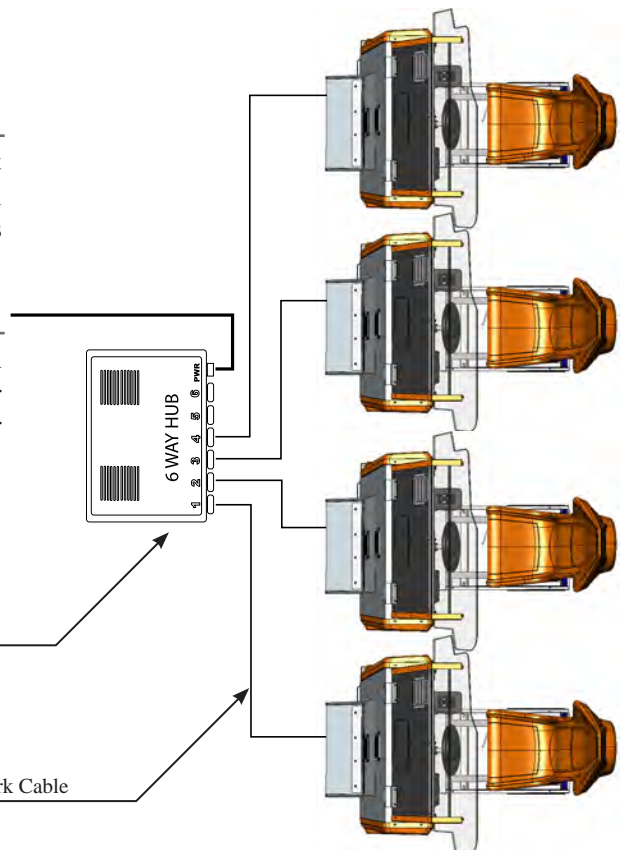

A typical illustration of 4 seats in a network

## 17-3 NETWORK PLAY SETTINGS

Each of the linked machines must be set up for network play. If the machines are not set up correctly, network play will not be possible.

For this game, up to 4 machines can be connected to allow up to 4 players to play simultaneously.

- 1 Turn on the power on each machine to be used in network play.
- 2 Initiate TEST MODE on ALL machines.
- 3 Select the GAME TEST MODE and press the Test button to display the GAME TEST MENU screen.
- 4 Select the NETWORK SETTINGS in the GAME TEST MENU screen and press the Test button.

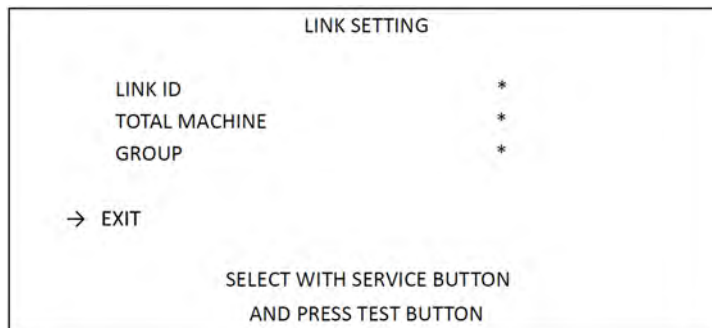

Link setting screen

- 5 Perform the CABINET ID setting. Set the different LINK ID number to each machine. Be sure to assign one of them with the ID number of "1"
- 6 Cause all of the machines to exit from the TEST MODE. Always select EXIT in the SYSTEM TEST MENU screen. DO NOT remove power as settings will be lost.



## 17-4 NETWORK PLAY PRECAUTIONS

### **STOP** IMPORTANT

- In network play, difficulty level and other settings are made from CABINET ID Number 1. Changing the settings at CABINET ID Number 1 also changes the settings for other units.
- Only use the network cable supplied to network 2 machines. When connecting 3 or more cabinets a Network Hub **MUST** be used along with standard Lan Network Cables).
- When networking machines it is important that all trailing network cables are placed safely away from players and observers alike. Untidy cables may cause a trip or electrical hazard.

# 18 DESIGN RELATED PARTS

For the warning display stickers, refer to Section 1.



PD-0002UK



PD-1356UK



PD-2020UK



PD-2015UK



PD-1503UK



PD-1504UK



PD-1505UK



PD-2201K

# 19 PARTS LIST

19

PARTS LIST

TOP ASSY KO DRIVE STD US

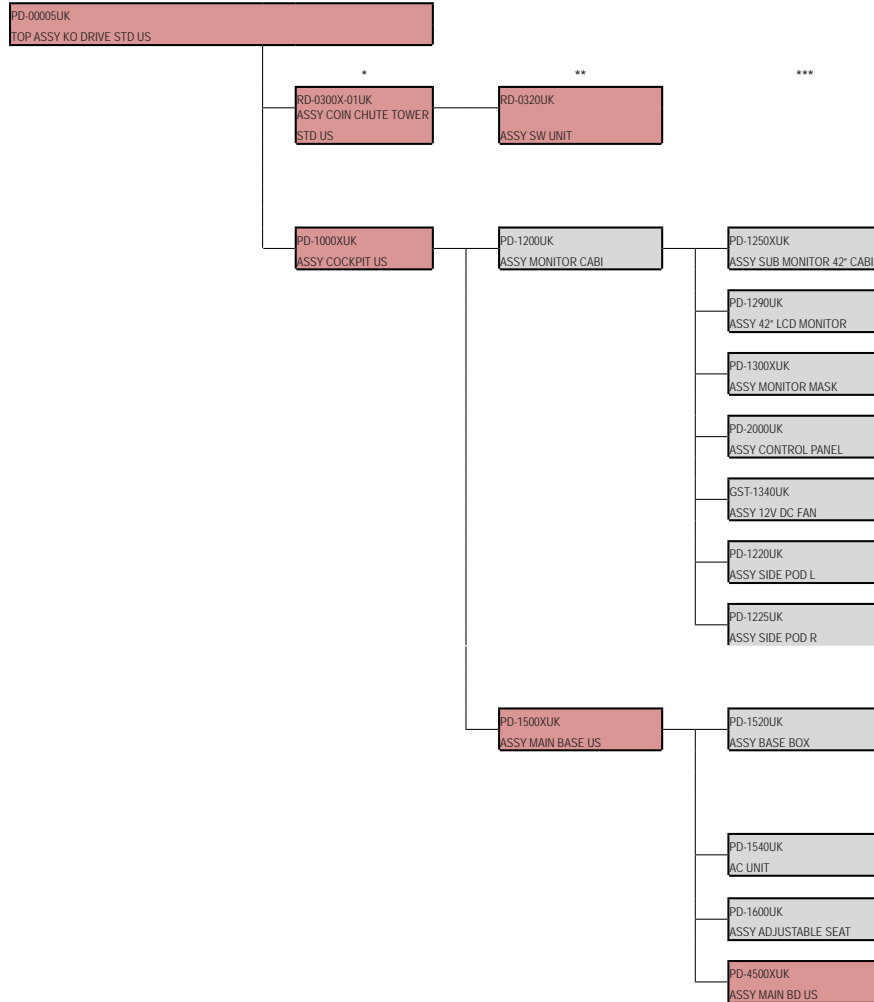

① ASSY TOP KO DRIVE STD US (PD-00005UK)

(D-1/2)

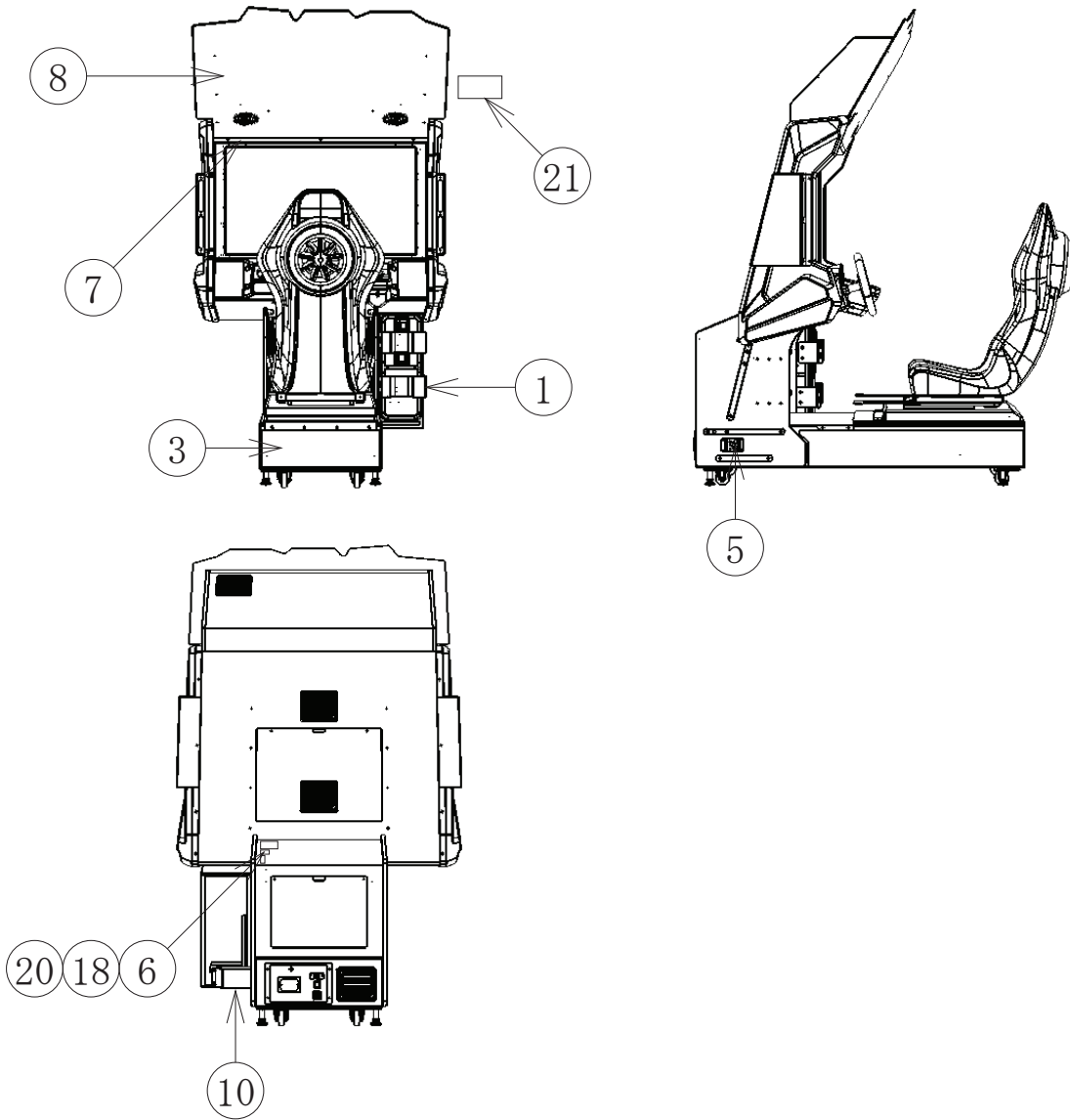

① ASSY TOP KO DRIVE STD US (PD-00005UK)

(D-2/2)

ITEM NO	PART NUMBER	DESCRIPTION	QTY
*1	PD-0300X-01UK	ASSY COIN CHUTE TOWER STD US	1
*3	PD-1000XUK	ASSY COCKPIT US	1
*5	RD-0004UK	PLATE CCT BLANK	1
*6	421-7988-91UK	STICKER SERIAL NUMBER UK	1
*7	PD-1355UK	BRKT SPKR PNL LWR	1
*8	PD-1356UK	CENTRE PNL SPKR LEADER	1
**1	PD-1356-AUK	CENTRE PNL SPKR LEADER BLANK	1
*10	RD-0001UK	WIRE COVER	1
*12	421-7020UK	STICKER CAUTION FORK	2
*15	440-CS0186UK	STICKER C EPILEPSY MULTI	1
*16	PD-1002UK	BRKT CABI LOWER	2
*17	LB1102	STICKER DANGEROUS VOLTAGE	3
*18	LB1046	LABEL TESTED FOR ELEC. SAFETY	1
*20	LB1130	LABEL WEEE WHEELIE BIN	1
*21	LB1170	LABEL AAMA ALL AGES	1
*201	050-F00800	M8 NUT FLG SER PAS	8
*202	068-852216	M8 WSHR 22OD FLT PAS	8
*203	000-P00408-WB	M4X8 MSCR PAN W/FS BLK	2
*204	000-P00416-WB	M4X16 MSCR PAN W/FS BLK	5
*205	068-441616-0B	M4 WSHR 16OD FLT BLK	13
*206	000-P00412-W	M4X12 MSCR PAN W/FS PAS	1
*207	060-F00400	M4 WSHR FORM A FLT PAS	1
*212	OS1019	SELF SEAL BAG 9X12.3/4	1
*213	000-T00416-0B	M4X16 MSCR TH BLK	8
*301	600-7269-0200UK	LAN CABLE 200CM	1
*401	SAECE-xxx	DECLARATION OF CONFORMITY	1
*403	LM1227	UK MAINS LEAD 10A WITH PLUG	1
*404	LM1246	EUROLEAD 10A EUROPEAN SOCKET	1
*405	PK0485	PALLET PD TW	1
*406	PK0468	SHRINK WRAP RD STD	1
*407	OS1248	TAPE D-S 12MMX10X	0.3mt

② ASSY COIN CHUTE TOWER STD US (RD-0300X-01UK)

(D-1/1)

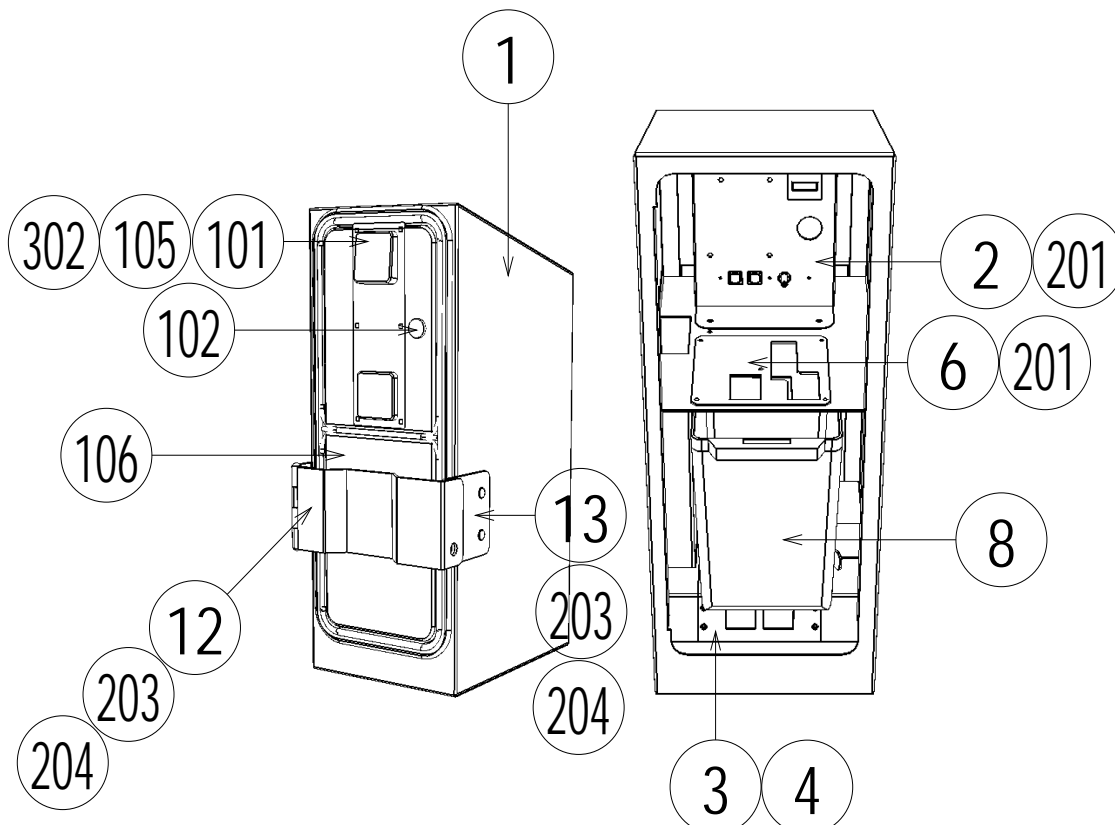

ITEM NO	PART NUMBER	DESCRIPTION	QTY
**1	RD-0301XUK	COIN CHUTE TOWER	1
**2	RD-0320UK	ASSY SW UNIT	1
**5	RD-0305UK	SPACER CCT STD	1
**6	RD-0306UK	PLATE BLANK CCT STD	1
**101	220-5732-01	DFMD SAU HAPP H40-7000-00	1
**102	OS1247	ALUMINIUM STICKY CLIP ASK-3	3
**201	000-P00410-W	M4X10 MSCR PAN W/FS PAS	4
**202	000-F00408	M4X8 MSCR CSK PAS	4
**203	050-F00600	M6 NUT FLG SER PAS	5
**204	068-652016	M6 WSHR 20OD FLT PAS	5
**303	600-9060-44K	WH EARTH 60CM M4M4	1
**304	RD-60043UK	WH DBA POWER	1
**305	RND-60055UK	WH COIN MECHANICAL	1

③ ASSY SW UNIT (RD-0320XUK)

(D-1/1)

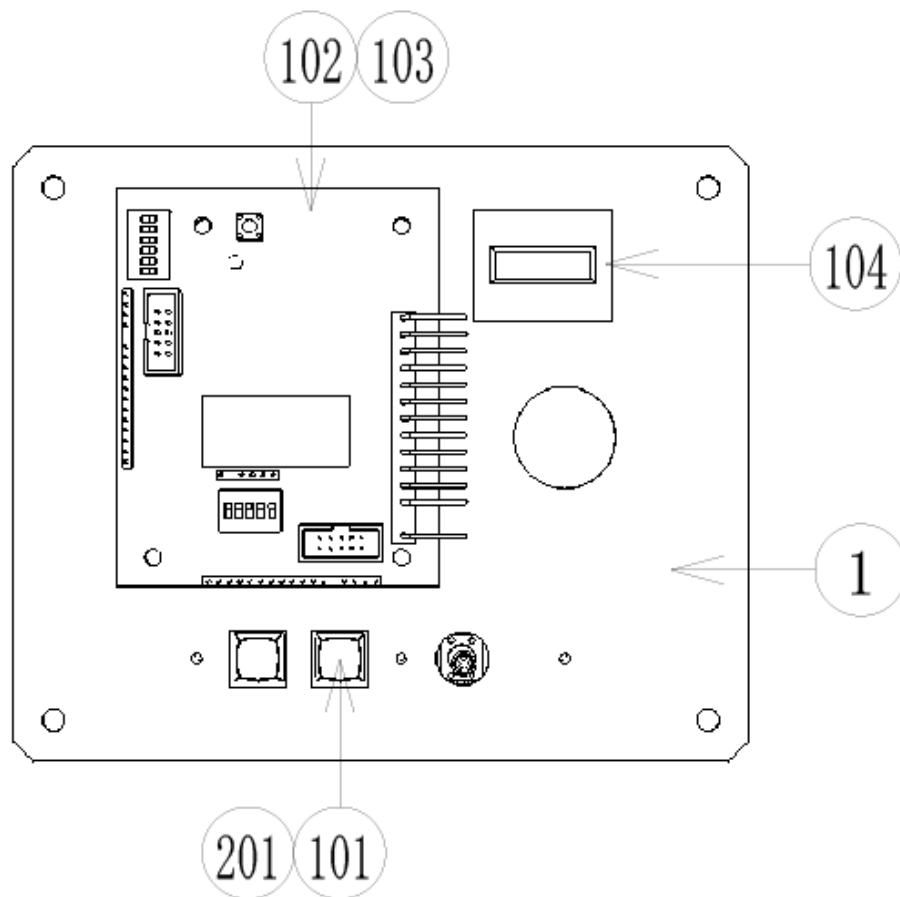

ITEM NO	PART NUMBER	DESCRIPTION	QTY
***1	RD-0321-01UK	SW BRKT US	1
***101	838-14548-01UK	SW & VOL CTL BD	1
***102	280-L00706-PM	STANDOFF 6.4MM HOLE PM	4
***103	EP1380-01	CREDIT BOARD EXCEL	1
***104	220-5643UK	COIN METER SMALL 12V	1
***105	OS1247	ALUMINIUM STICKY CLIP ASK-3	1
***107	OS1098	CRIMP BELL END SMALL	2
***108	601-0460	CABLE TIE NYLON 100MM	2
***111	LB1152	STICKER VTS	1
***112	LB1155	STICKER COINS IN	1
***201	000-P00308-W	M3X8 MSCR PAN W/FS PAS	3
***301	RD-60003UK	WH COIN HANDLING	1

④ ASSY COCKPIT US (PD-1000XUK)

(D-1/1)

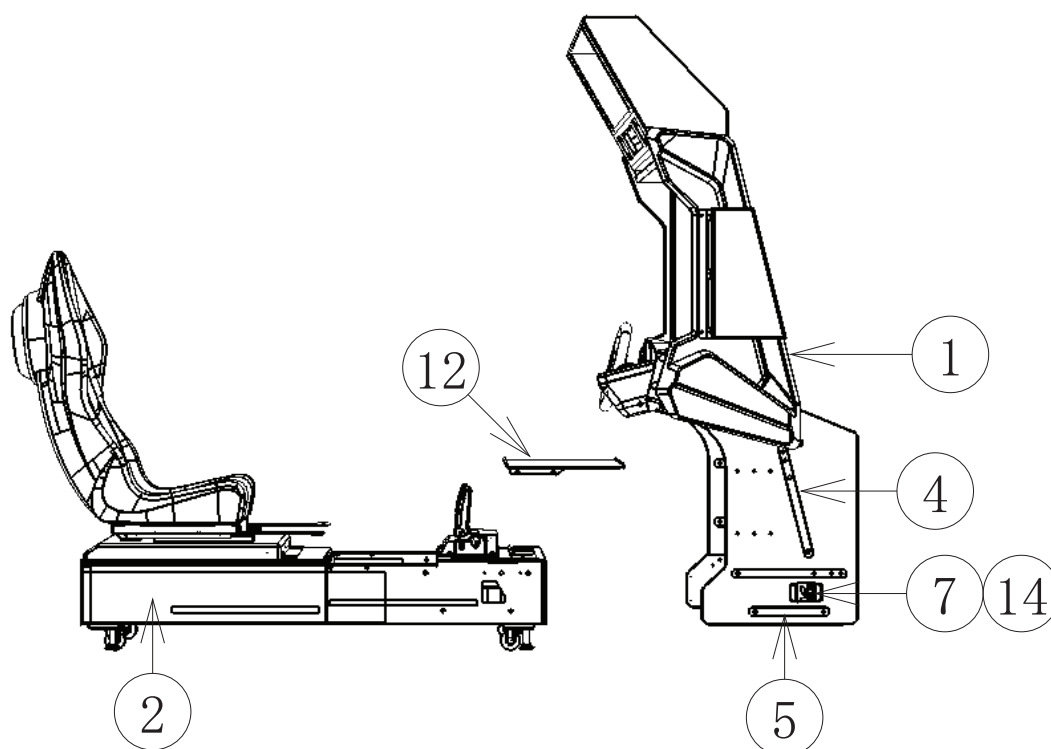

ITEM NO	PART NUMBER	DESCRIPTION	QTY
**1	PD-1200UK	ASSY MONITOR CABI	1
**2	PD-1500XUK	ASSY MAIN BASE US	1
**4	RD-1001UK	MON CABI PLATE UPPER	4
**7	RD-1004UK	STRUT CABINET SUPPORT	2
**8	RD-1005UK	BRKT OUTER CABI SUPP	2
**12	PD-1502UK	BASE LID F	1
**14	RD-1011UK	PLATE CONN BASE BOX	2
**201	030-000840-SB	M8X40 BLT W/S BLK	14
**202	068-852216-0B	M8 WSHR 22OD FLT BLK	18
**205	050-F00400	M4 NUT FLG SER PAS	4
**207	060-F00400	M4 WSHR FORM A FLT PAS	3
**208	000-T00416-0B	M4X16 MSCR TH BLK	3
**209	000-T00412-0C	M4X12 MSCR TH CRM	4
**210	030-000635-S	M6X35 BLT W/S PAS	6
**211	031-000640-0B	M6X40 CRG BLT BLK	8
**212	068-652016	M6 WSHR 20OD FLT PAS	14
**213	050-F00600	M6 NUT FLG SER PAS	8
**214	068-441616-0C	M4 WSHR FLT CRM	4
**301	600-9010-44K	WH EARTH 10CM M4M4	3
**302	600-9020-44K	WH EARTH 20CM M4M4	4
**303	600-9040-44K	WH EARTH 40CM M4M4	1
**304	600-9050-44K	WH EARTH 50CM M4M4	1
**305	600-9060-44K	WH EARTH 60CM M4M4	1
**306	600-9120-44K	WH EARTH 120CM M4M4	1
**307	600-7009-1800UK	ASSY RGB CA D-SUB 15	1
**308	RD-60042UK	WH COIN HANDLING B	1



⑤ ASSY MONITOR CABI (PD-1200UK)

(D-1/3)

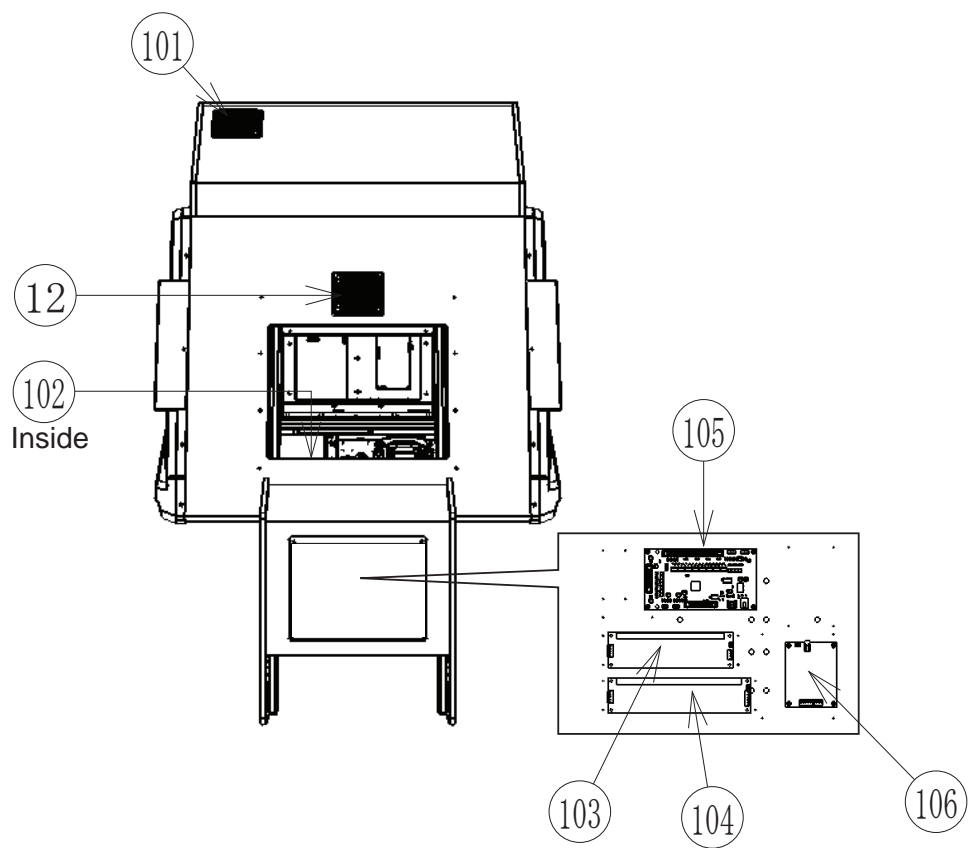
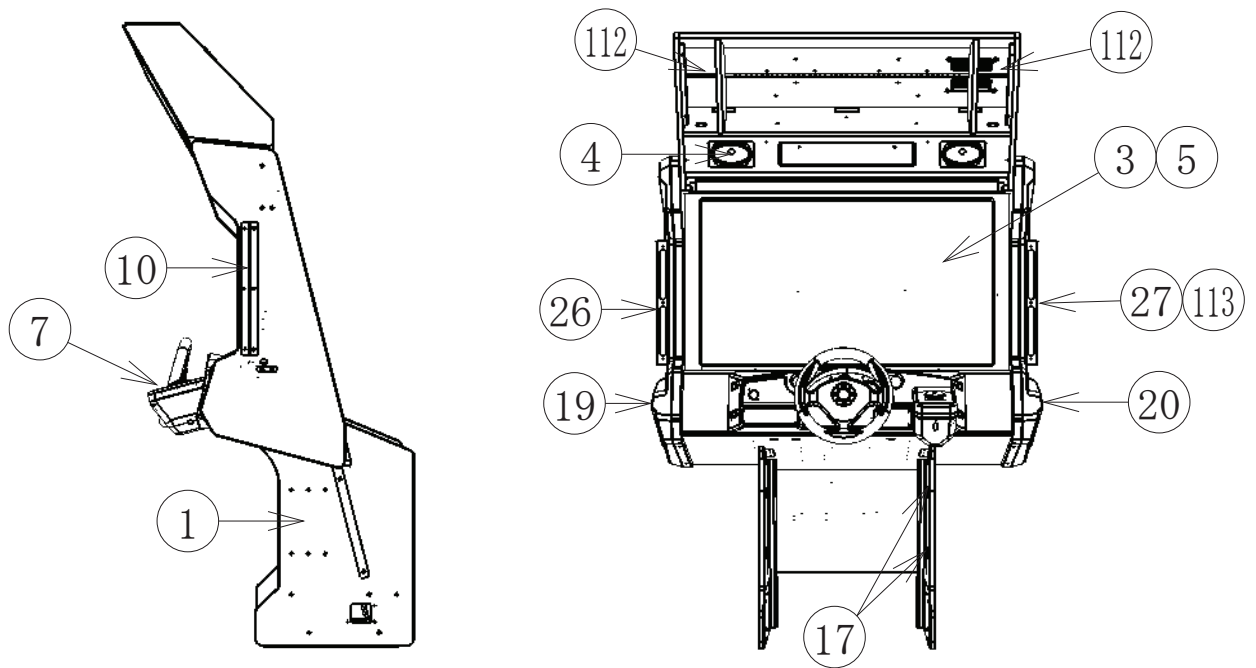

# 5 ASSY MONITOR CABI (PD-1200UK)

(D-2/3)

ITEM NO	PART NUMBER	DESCRIPTION	QTY
***1	PD-1250XUK	ASSY SUB MONITOR 42" CABI	1
***3	PD-1290UK	ASSY 42" LCD MONITOR	1
***4	130-5284	SPEAKER 8OHM F01612HO NJS	2
***5	PD-1300XUK	ASSY MONITOR MASK	1
***7	PD-2000UK	ASSY CONTROL PANEL	1
***10	RD-1203UK	SIDE PANEL HOLDER	2
***12	GST-1340UK	ASSY 12V DC FAN	1
***14	RD-1207UK	MONITOR CABI SPACER L	1
***15	RD-1208UK	MONITOR CABI SPACER R	1
***17	RD-1214UK	CHUTE TOWER HOLDER	4
***19	PD-1209-AUK	SIDE PANEL L BLANK	1
***20	PD-1210-AUK	SIDE PANEL R BLANK	1
***26	PD-1220UK	ASSY SIDE POD L	1
***27	PD-1225UK	ASSY SIDE POD R	1
***101	253-5460-01	AIR VENT BLACK	3
***102	838-15069	MOTOR DRIVE BD RS232/422	1
***103	400-050-024-01	PSU 24VDC 50W MW LPS-50-24	1
***104	400-075-012-01	PSU 12VDC 75W MW LPS-75-12	1
***105	837-14572	I/O CONTROL BD 3 FOR JVS	1
***106	838-14988	2 CH 30W AUDIO AMP ST	1
***108	OS1011	PCB FEET RICHCO LCBS-L-5-01	8
***109	280-A00748-PM	ROUTER TWIST D7 S04.8 PANEL M	4
***112	SSR-60022-040UK	WH LED ASSY 400	2
***113	SSR-60022-080UK	WH LED ASSY 800	2
***201	000-P00416-W	M4X16 MSCR PAN W/FS PAS	6
***202	050-F00600	M6 NUT FLG SER PAS	8
***203	012-P03506-F	N6X1/4" S/TAP FLG PAS	8
***204	068-652016	M6 WSHR 20OD FLT PAS	8
***205	012-P03512-F	N6X1/2" S/TAP FLG PAS	8
***206	068-441616-OB	M4 WSHR 16OD FLT BLK	18
***207	029-B00870-OB	M8X70 SKT BH BLK	4
***209	068-852216-OB	M8 WSHR 22OD FLT BLK	4
***210	000-T00412-OB	M4X12 MSCR TH BLK	18
***211	012-F03512	N6X1/2" S/TAP CSK PAS	12
***212	000-T00416-OB	M4X16 MSCR TH BLK	12
***213	050-F00400	M4 NUT FLG SER PAS	3
***214	060-F00400	M4 WSHR FORM A FLT PAS	3
***216	000-P00420-W	M4X20 MSCR PAN W/FS PAS	4
***218	012-P00325	N4X1" S/TAP PAN PAS	12

## ⑤ ASSY MONITOR CABI (PD-1200UK)

(D-3/3)

***301	PD-60004UK	WH DC 12V OUT	1
***302	PD-60008UK	WH ENCODER & MOTOR A	1
***303	PD-60009UK	WH SPKR A	1
***304	PD-60010UK	WH I/O	1
***305	PD-60011UK	WH AC DISTRIBUTION EXTN	1
***306	PD-60012UK	WH 5V I/O EXTN	1
***307	PD-60013UK	WH COMS B	1
***308	PD-60014UK	WH PEDALS	1
***309	PD-60015UK	WH AC 100 MOTOR	1
***310	PD-60016UK	WH LED/BUTTONS	1
***312	PD-60019UK	WH LCD POWER	1
***313	PD-60020UK	WH FAN / BB LED	1
***314	PD-60021UK	WH SPKR EXTN	1
***315	PD-60022UK	WH RACE LEADER EXTN	1
***316	PD-60024UK	WH SPKR L	1
***317	PD-60025UK	WH SPKR R	1
***318	PD-60026UK	WH RACE LEADER	1
***319	PD-60027UK	WH FAN EXTN	1
***320	PD-60031UK	WH SIDE LED	1
***321	600-7141-100UK	CABLE JVS TYPE A-B 100cm	1
***322	BE-60028UK	WH RIGID LED	1

⑥ ASSY SUB MONITOR CABI (PD-1250XUK)

(D-1/1)

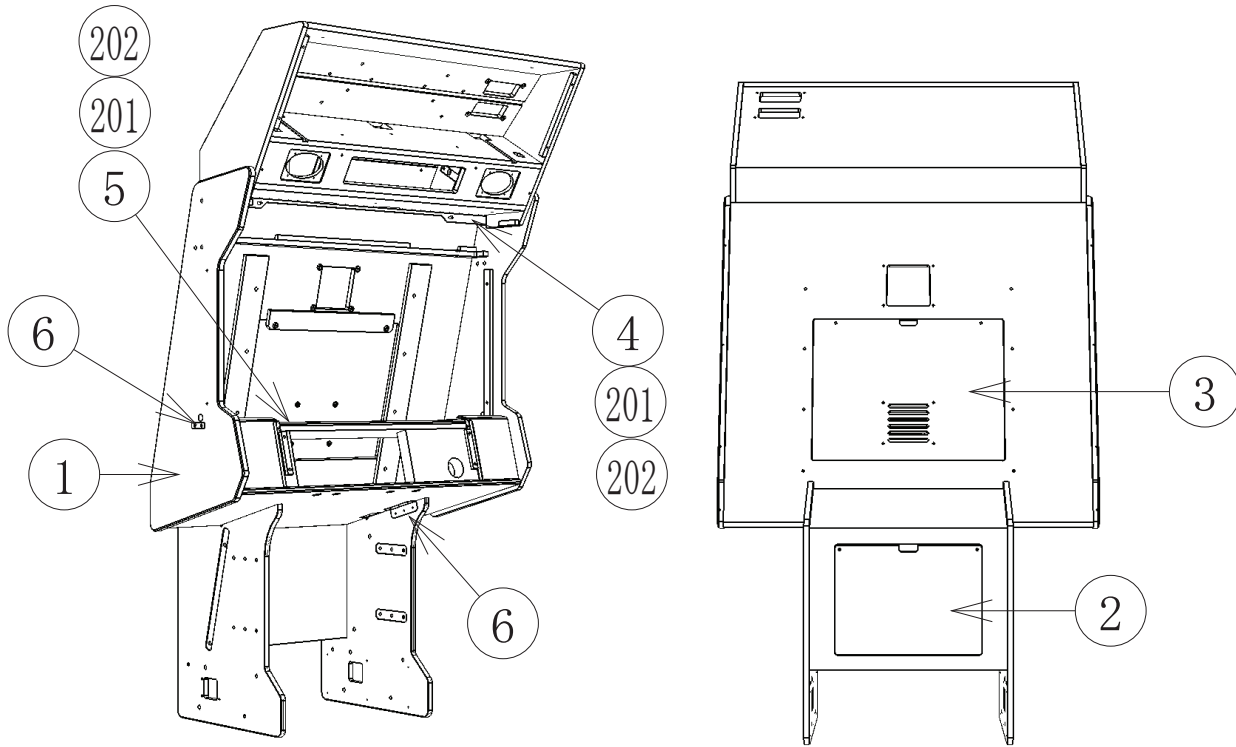

ITEM NO	PART NUMBER	DESCRIPTION	QTY
****1	PD-1251UK	MONITOR CABINET	1
*****2	RD-1021UK	WOODEN LOWER DOOR	1
*****3	RD-1003UK	UPPER DOOR	1
****4	PD-1257UK	BRKT 42 MONITOR UPPER SUPPORT	1
****5	PD-1255UK	MONITOR SUPPORT	1
****6	RD-1256UK	MONITOR SUPPORT PLATE	4
****201	030-000630-SB	M6X30 BLT W/S BLK	9
****202	068-652016	M6 WSHR 20OD FLT PAS	6

⑦ ASSY LCD MONITOR (PD-1290UK)

(D-1/1)

19

PARTS LIST

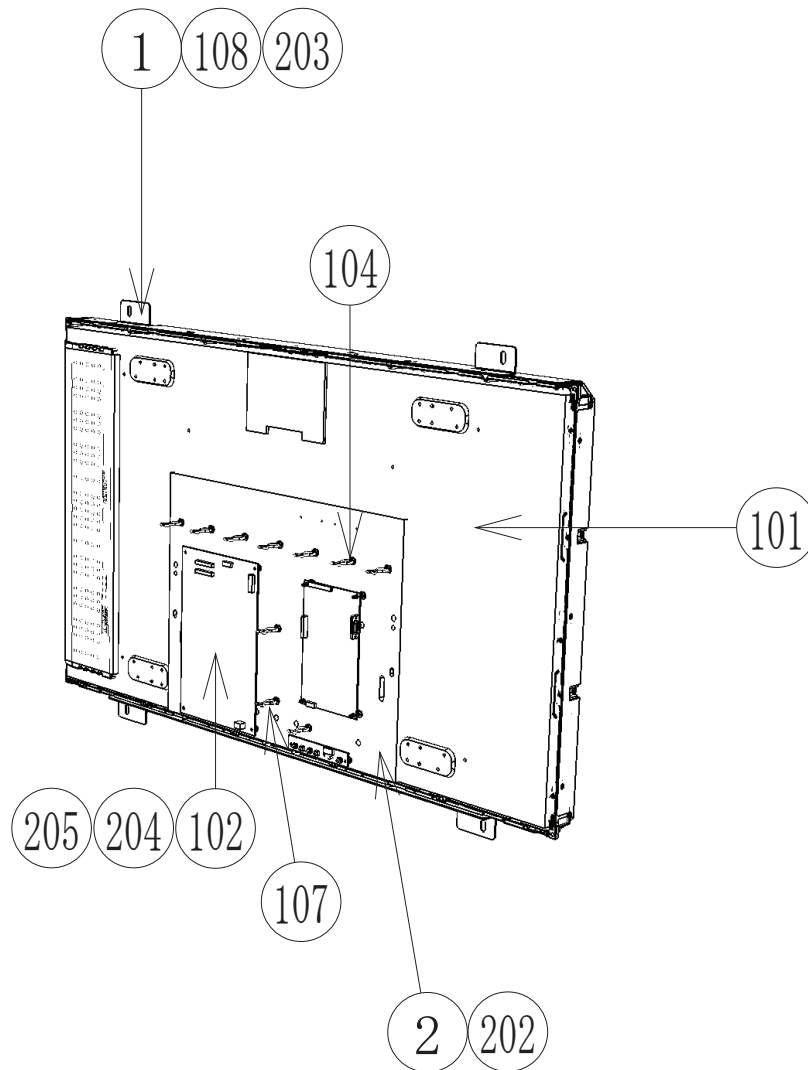

ITEM NO	PART NUMBER	DESCRIPTION	QTY
****1	PD-1281UK	LCD BRKT	2
****2	GST-1110UK	PANEL PRISMA BD MOUNT	1
****101	200-6042-01-AUO	DISPLAY 42" LCD T420HW09-V2	1
****102	400-242-024-01	PSU 42" LCD PVP-2420	1
****103	280-L00640-WX	STANDOFF 6MM WOOD XL	4
****104	280-A00748-PM	ROUTER TWIST D7 SO4.8 PANEL M	4
****107	280-A01264-WX	ROUTER TWIST D12 SO6.4 WOOD X	4
****108	OS1230	FOAM STRIP 2MM X 10MM	2.3m
****202	000-P00416-W	M4X16 MSCR PAN W/FS PAS	2
****203	000-P00410-W	M4X10 MSCR PAN W/FS PAS	6
****204	012-P00320	N4X3/4" S/TAP PAN PAS	7
****205	280-L00709-OS	STANDOFF 7OD 4ID 9L	7

⑧ ASSY MONITOR MASK (PD-1300XUK)

(D-1/1)

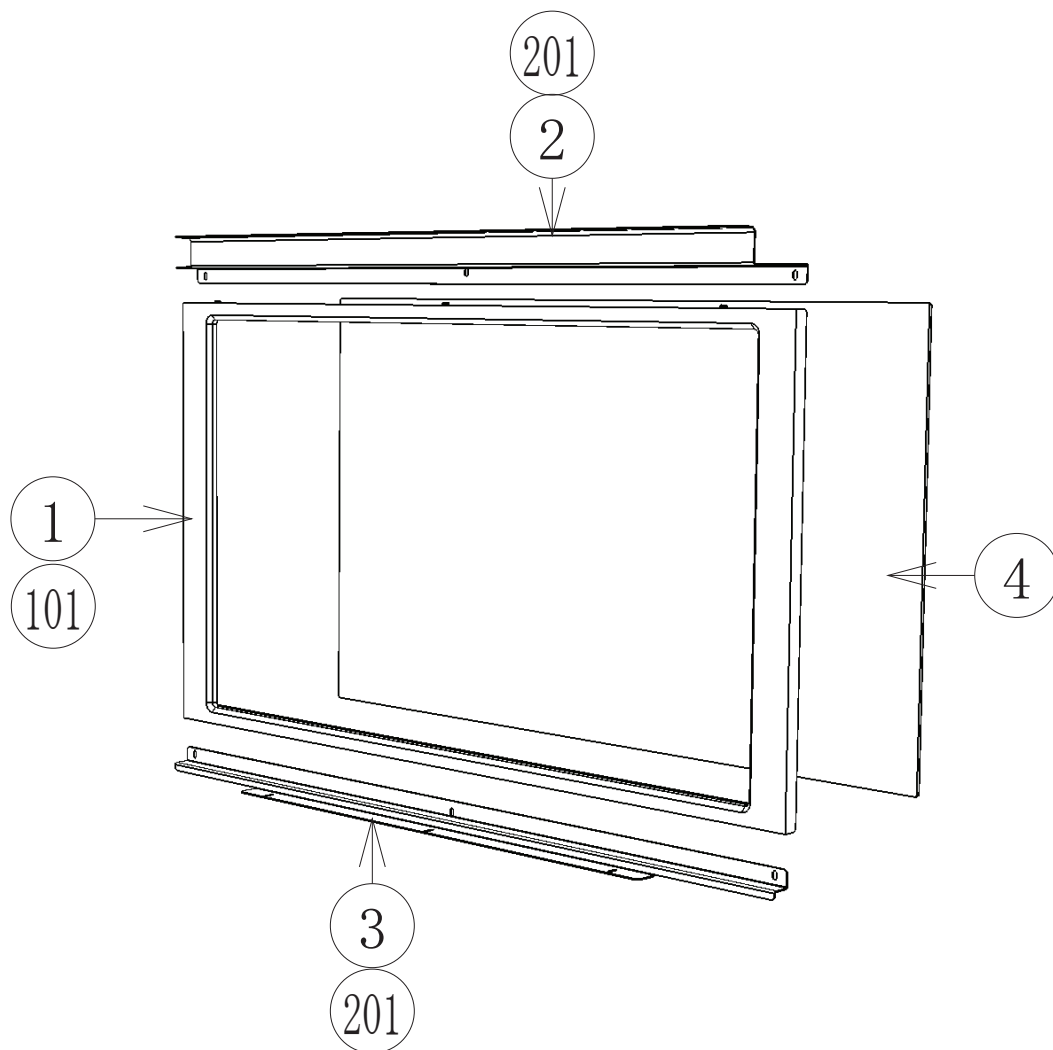

ITEM NO	PART NUMBER	DESCRIPTION	QTY
****1	PD-1301UK	MASK MONITOR	1
****2	PD-1304UK	BRKT MASK UPPER	1
****3	PD-1305UK	BRKT MASK LOWER	1
****4	PD-1308XUK	GLASS 42 LCD PROTECTIVE	1
****101	OS1230	FOAM STRIP 2MM X 10MM	2m
****201	000-P00410-W	M4X10 MSCR PAN W/FS PAS	5

⑨ ASSY CONTROL PANEL (PD-2000UK)

(D-1/2)

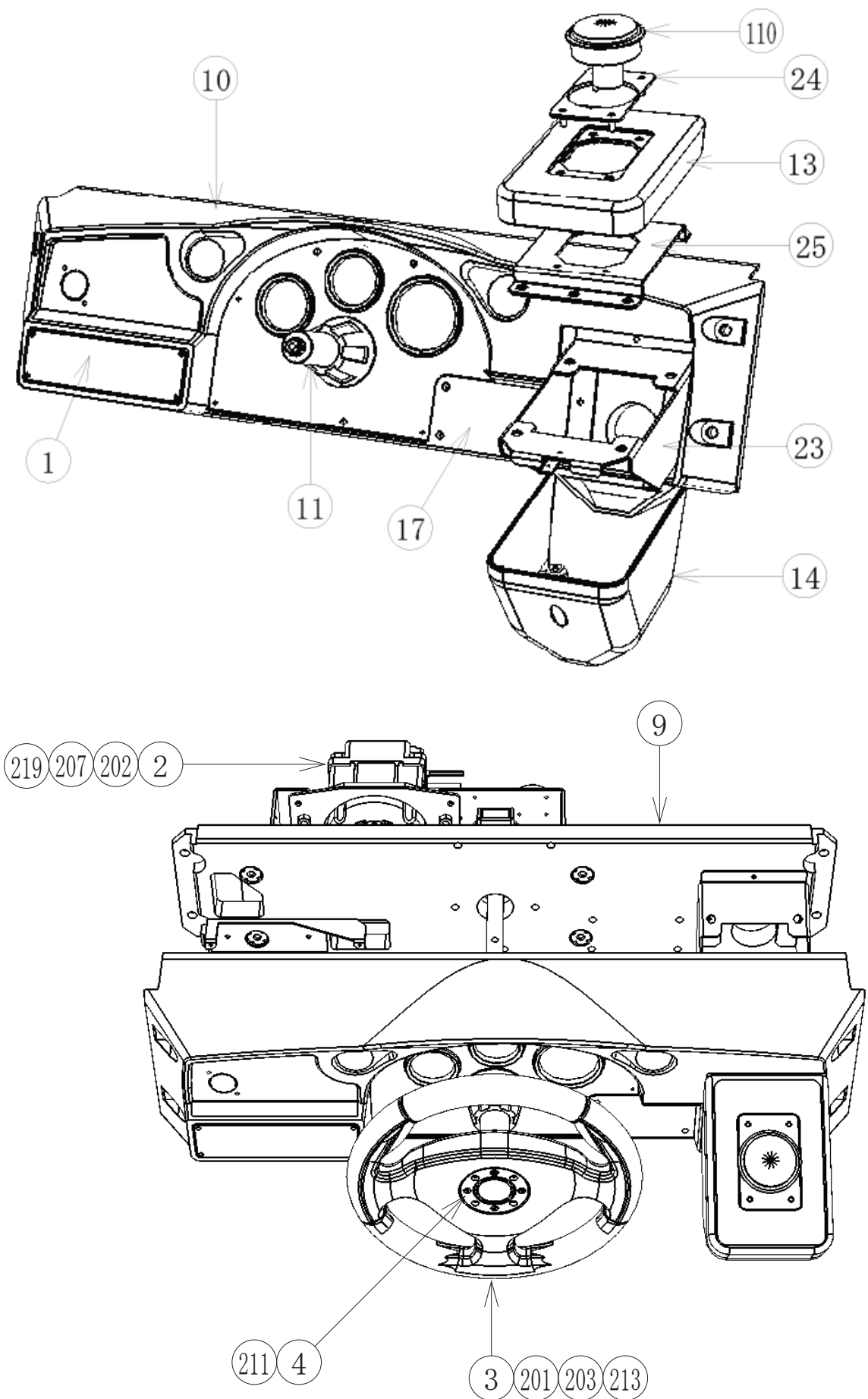

# ⑨ ASSY CONTROL PANEL (PD-2000UK)

(D-2/2)

ITEM NO	PART NUMBER	DESCRIPTION	QTY
****1	PD-2202UK	PLATE LOGO	1
****2	610-0875	ASSY HANDLE MECHA	1
****3	SPG-2001X-N	STEERING WHEEL	1
****4	SPG-2002	STEERING EMBLEM	1
****9	PD-2007UK	PANEL HANDLE MECHA	1
****10	PD-2001UK	CTRL PANEL COVER	1
****11	DYN-1209X	HANDLE COLLAR	1
****13	INY-1204	SHIFT COVER INY	1
****14	DYN-1223X	SHIFT COVER B	1
****16	PD-0002UK	STICKER SUB INSTR	1
****17	DYN-0010UK	DENOMI PLATE	1
****21	PD-2020UK	STICKER FIRE BUTTON	1
****23	PD-2003UK	BRKT SHIFTER	1
****24	PD-2004UK	PLATE ACTION BUTTON	1
****25	PD-2005UK	BASE ACTION BUTTON	1
****102	280-A01200-A	ROUTER TWIST D12 ADH	4
****103	280-A02000-A	ROUTER TWIST D20 ADH	1
****110	509-0001-RE	BTN 12V 1.2W S'POINT CPBL	1
****111	LB1167	LABEL LAMP 12V 1.2W	1
****201	020-000820	M8X20 BLT PAS	1
****202	060-F00800	M8 WSHR FORM A FLT PAS	4
****203	060-S00800	M8 WSHR SPR PAS	1
****205	000-P00412-W	M4X12 MSCR PAN W/FS PAS	3
****206	030-000820-S	M8X20 BLT W/S PAS	4
****207	020-000830	M8X30 BLT PAS	4
****208	008-T00416-0B	M4X16 TMP PRF TH BLK	11
****211	FAS-200013	M4X16 SKT CAP CRM	4
****212	050-F00400	M4 NUT FLG SER PAS	8
****213	060-F01600	M16 WSHR FORM A FLT PAS	2
****218	000-P00430-WB	M4X30 MSCR PAN W/FS BLK	3
****219	030-000830-SB	M8X30 BLT W/S BLK	4
****301	PD-60017UK	WH FIRE BUTTON	1
****302	600-9120-44K	WH EARTH 120CM M4M4	1



⑩ ASSY SIDE POD L (PD-1220UK)

(D-1/1)

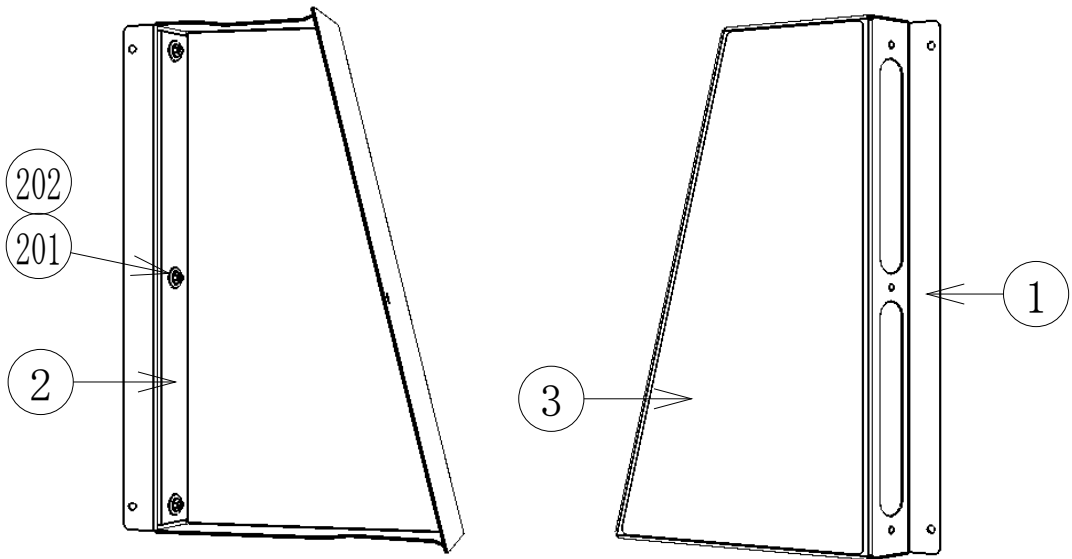

ITEM NO	PART NUMBER	DESCRIPTION	QTY
***1	PD-1215UK	POD SIDE L	1
***2	PD-1217UK	PERSPEX SIDE POD	1
***3	PD-1221UK	STICKER SIDE PANEL L	1
***201	050-F00400	M4 NUT FLG SER PAS	3
***202	068-441616	M4 WSHR 16OD FLT PAS	3

⑪ ASSY SIDE POD R (PD-1225UK)

(D-1/1)

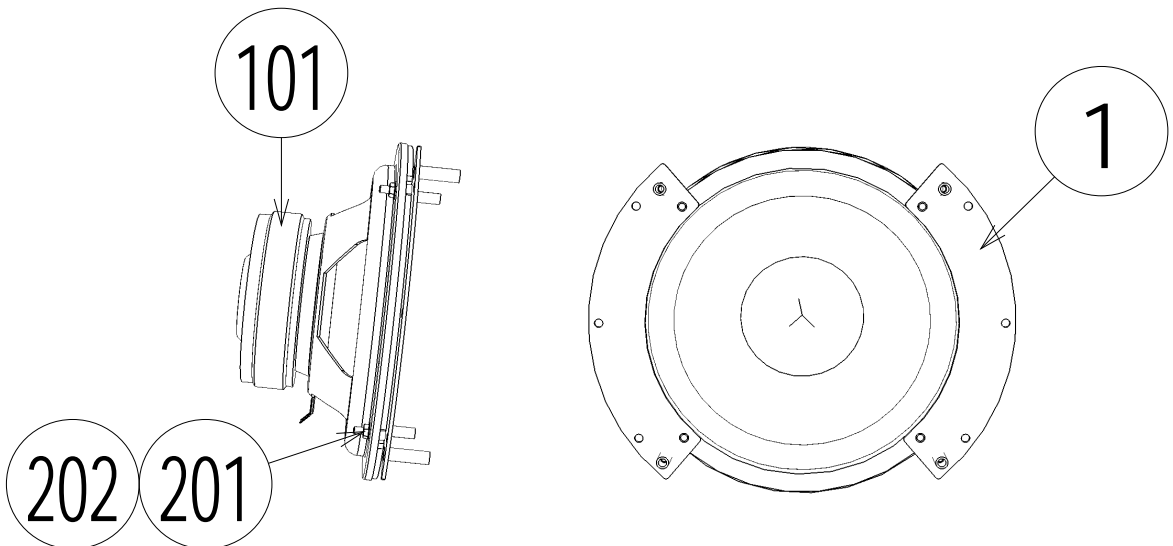

ITEM NO	PART NUMBER	DESCRIPTION	QTY
***1	PD-1216UK	POD SIDE R	1
***2	PD-1217UK	PERSPEX SIDE POD	1
***3	PD-1222UK	STICKER SIDE PANEL R	1
***201	050-F00400	M4 NUT FLG SER PAS	3
***202	068-441616	M4 WSHR 16OD FLT PAS	3

⑫ ASSY MAIN BASE (PD-1500XUK)

(D-1/2)

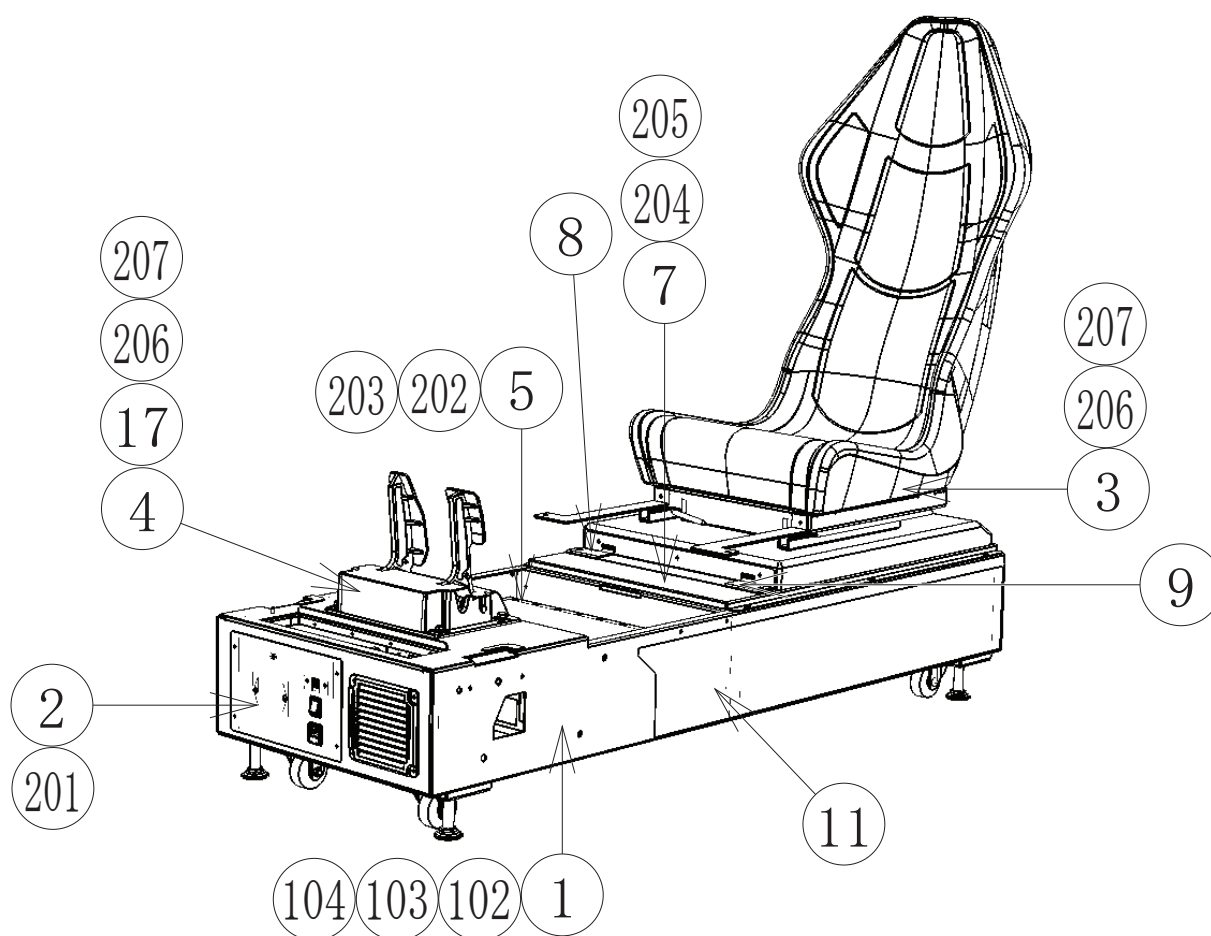

ITEM NO	PART NUMBER	DESCRIPTION	QTY
***1	PD-1520UK	ASSY BASE BOX	1
***2	PD-1540UK	AC UNIT	1
***3	PD-1600UK	ASSY ADJUSTABLE SEAT	1
***4	610-0874-01	ASSY ACCEL & BRAKE	1
***5	PD-4500XUK	ASSY MAIN BD US	1
***7	PD-1538UK	BASE LID R	1
***8	RAL-2007X	RUBBER HOLDER R TWIN	1
***9	RAL-2008X	RUBBER HOLDER L TWIN	1
***11	PD-1503UK	STICKER MAIN BASE L	1
***12	PD-1504UK	STICKER MAIN BASE R	1
***13	PD-1505UK	STICKER MAIN BASE REAR	1
***17	SPG-2224UK	PEDAL GASKET	1
***102	260-0012-01UK	FAN DC 12V ROHS	1
***103	FN1012	FAN GUARD METAL 120MM	2
***104	OS1195	RIVET SNAP MOSS SR1811	4

⑫ ASSY MAIN BASE (PD-1500XUK)

(D-2/2)

***201	000-P00408-WB	M4X8 MSCR PAN W/FS BLK	4
***202	032-000425	M4X25 W/BLT PAS	2
***203	068-441616	M4 WSHR 16OD FLT PAS	2
***204	030-000620-SB	M6X20 BLT W/S BLK	6
***205	060-F00600-SB	M6 WSHR FORM A FLT BLK	6
***206	030-000825-SB	M8X25 BLT W/S BLK	10
***207	060-F00800-OB	M8 WSHR FORM A FLT BLK	12
***209	030-000820-SB	M8X20 BLT W/S BLK	2
***214	008-T00512-OB	M5X12 TMP PRF TH BLK	4
***215	000-P00412-W	M4X12 MSCR PAN W/FS PAS	4
***301	600-9010-44K	WH EARTH 10CM M4M4	1
***302	600-9020-44K	WH EARTH 20CM M4M4	1

13 ASSY BASE BOX (PD-1520UK)

(D-1/1)

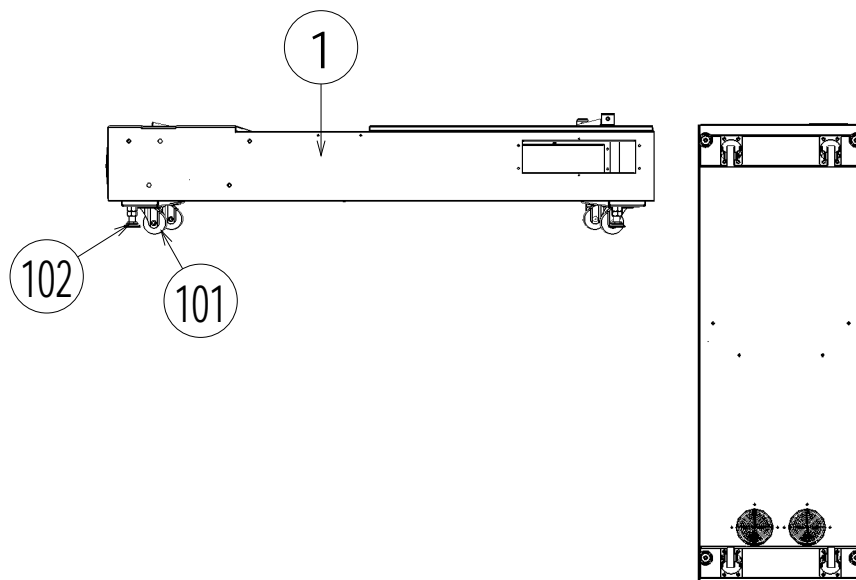

19

PARTS LIST

ITEM NO	PAT NUMBER	DESCRIPTION	QTY
****1	PD-1531UK	MAIN BASE BLANK	1
****102	MA1007	CASTOR SWIVEL 63mm NYLON	4
****103	601-5699UK-01	LEG ADJ M16X100 1L/NUT	4
****104	253-5460-01	AIR VENT BLACK	1
****204	030-000816	M8X16 BLT PAS	16
****205	060-S00800	M8 WSHR SPR PAS	16
****206	000-T00416-0B	M4X16 MSCR TH BLK	4

⑭ ASSY AC UNIT (PD-1540UK)

(D-1/1)

19

PARTS LIST

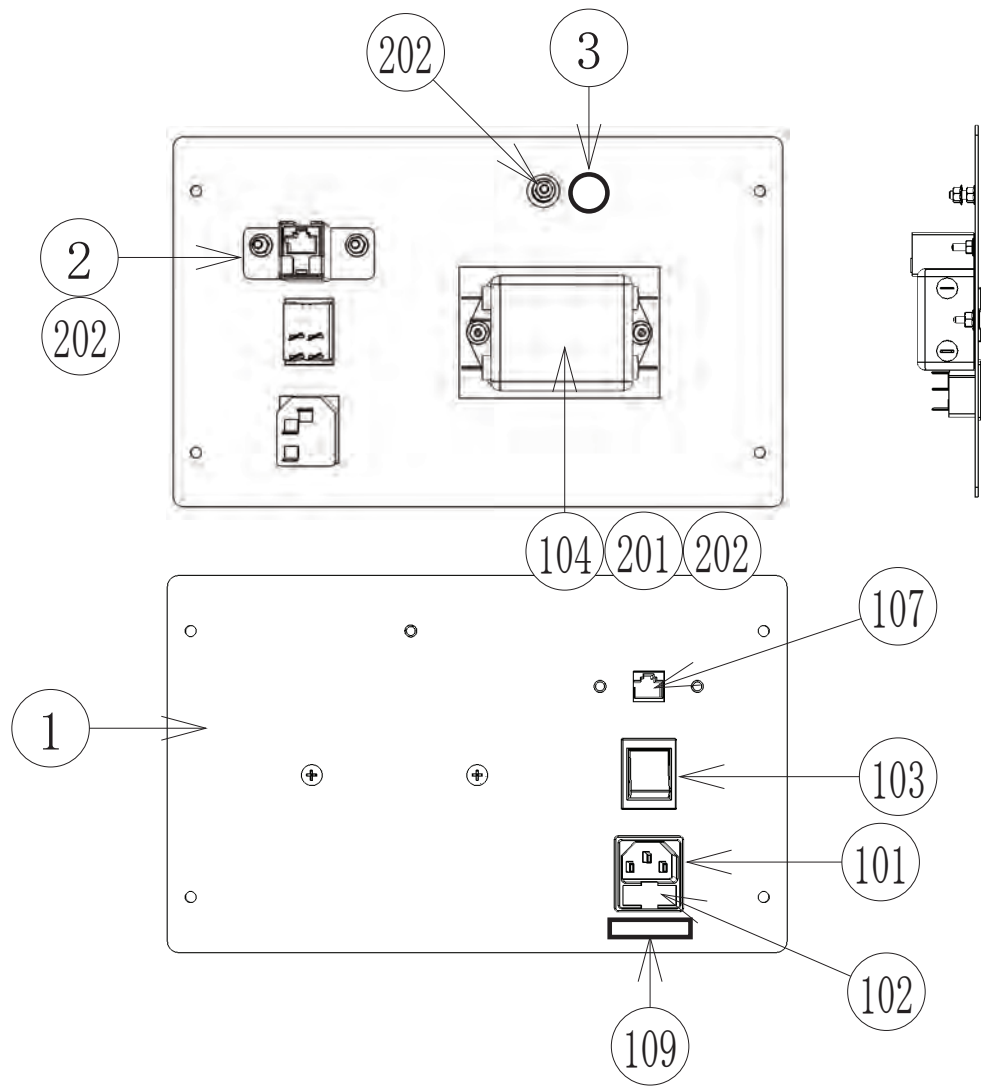

ITEM NO	PAT NUMBER	DESCRIPTION	QTY
****1	PD-1541UK	AC BRKT	1
****2	TFF-0402UK	CONN COVER	1
****3	LB1096	STICKER PROTECTIVE EARTH	1
****101	EP1302	EUROSOCKET FUSED 10A 250VAC	1
****102	514-5078-5000	FUSE 5X20 CERAMIC SB 5000mA	2
****103	SW1109	SWITCH ROCKER 250V AC	1
****104	EP1419	FILTER SCHAFFNER 2030-16-06	1
****107	EP1391	COUPLER INLINE LAN RJ45	1
****108	310-5029-D508	HEAT SHRINK SLEEVING 50.8DIA	4
****109	LB1126-5-250	FUSE LABEL 5A 250V	1
****201	000-P00410-W	M4X10 MSCR PAN W/FS PAS	2
****202	050-F00400	M4 NUT FLG SER PAS	6
****301	TFF-60001UK	WH AC IN	1
****302	600-9020-44K	WH EARTH 20CM M4M4	1
****303	RD-60037UK	WH AC BASE EXTN	1

15 ASSY ADJUSTABLE SEAT (PD-1600UK)

(D-1/1)

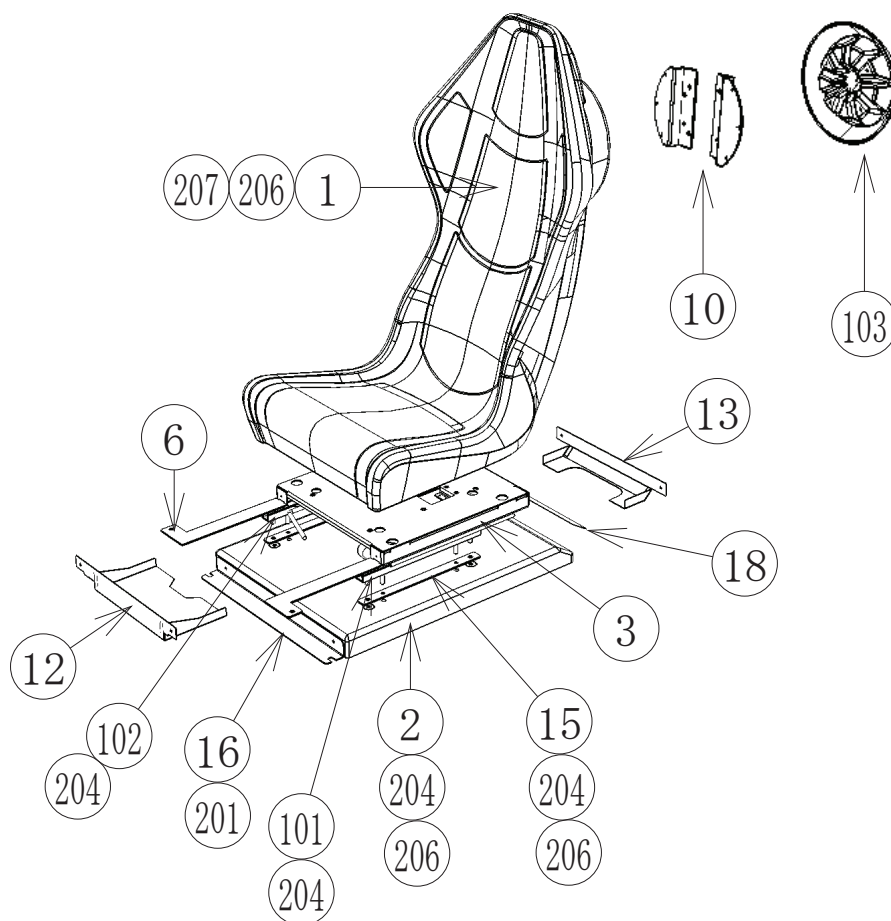

ITEM NO	PAT NUMBER	DESCRIPTION	QTY
****1	PD-1601-A	SEAT	1
****2	PD-1601UK	SEAT BASE	1
****3	RD-1602UK	SEAT TRAY	1
****6	RD-1605UK	PROTECT RUBBER	2
****10	PD-1676UK	BRKT REAR FORMING	2
****12	RD-1611UK	TRAY COVER FRONT	1
****13	RD-1612UK	TRAY COVER REAR	1
****15	PD-1614UK	PLATE SLIDER	2
****16	PD-1615UK	BRKT SEAT BASE FIX	1
****17	PD-1655UK	STICKER SEAT UPPER	1
****18	PD-1656UK	STICKER SEAT LOWER	1
****101	601-9059-91	SEAT RAIL L	1
****102	601-9060-91	SEAT RAIL R	1
****103	253-5678	DRIVING SEAT BACK COVER	1
****201	050-U00800	M8 NUT NYLOK PAS	12
****204	000-T00408-OB	M4X8 MSCR TH BLK	3
****205	012-P00416-FZ	N8X5/8" S/TAP FLG OZ	6
****206	068-852216	M8 WSHR 22OD FLT PAS	18
****207	030-000820-S	M8X20 BLT W/S PAS	6
****209	000-T00412-OC	M4X12 MSCR TH CRM	4

①⑥ ASSY MAIN BD (PD-4500XUK)

(D-1/1)

19

PARTS LIST

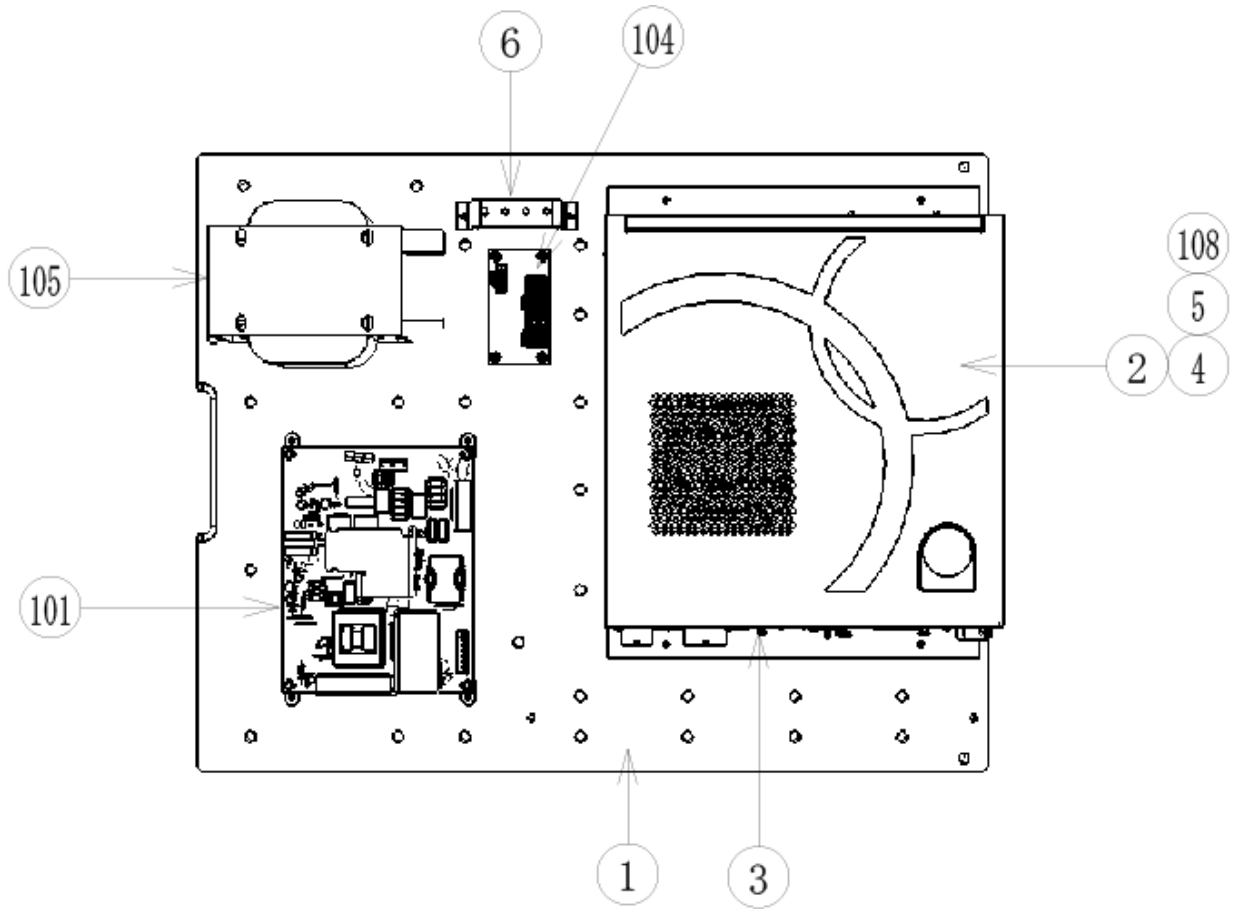

ITEM NO	PART NUMBER	DESCRIPTION	QTY
****1	PD-4501UK	WOODEN BASE MAIN BD	1
****2	847-0001D-02	ASSY CASE WDE W 1GB EXP	1
****3	253-5644-040BG	KEY CHIP RGW PD1	1
****4	610-0816-0049	DVD SOFT KIT PD1 E/S	1
****5	LB1111	STICKER PLEASE RECYCLE	1
****6	CFB-4003-01UK	EARTH PLATE	1
****101	400-5483	SW REGU EADP-130CF A DELTA	1
****102	280-A01264-WX	ROUTER TWIST D12 SO6.4 WOOD X	14
****103	280-A02064-WX	ROUTER TWIST D20 SO6.4 WOOD X	8
****104	838-14551-02UK	AC DISTRIBUTION BD	1
****105	560-1210-03UK	TRANSFORMER US 120-100V 3A	1
****108	LB1101	STICKER WARNING BATTERY	1
****201	000-P00416-W	M4X16 MSCR PAN W/FS PAS	8
****204	012-P00325	N4X1" S/TAP PAN PAS	8
****205	012-P03512-F	N6X1/4" S/TAP FLG PAS	2
****301	PD-60001UK	WH LINE FILTER TO AC DIST	1
****302	PD-60002UK	WH AC DISTRIBUTION	1
****303	PD-60003UK	WH AC TO XFMR UK	1
****304	PD-60005UK	WH DC RINGWIDE	1
****305	PD-60006UK	WH 5V I/O	1
****306	PD-60007UK	WH COMS A	1
****307	600-7269-0100UK	ASSY LAN CABLE 100CM	1

①⑦ ASSY 12VDC FAN (GST-1340UK)

(D-1/1)

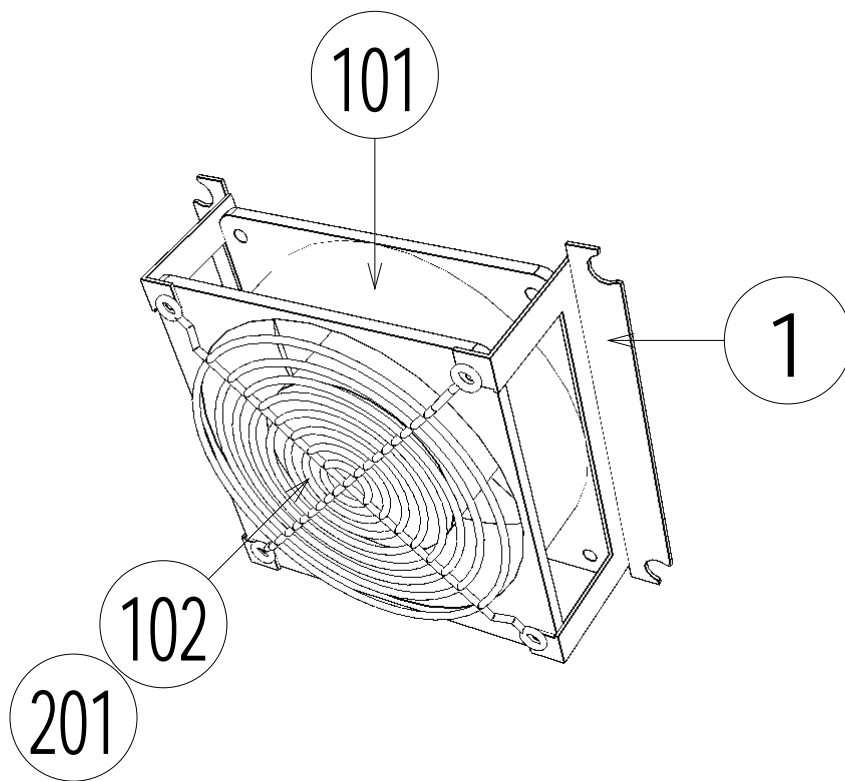

ITEM NO	PART NUMBER	DESCRIPTION	QTY
****1	105-5340-01	FAN BRKT LONG	2
****101	260-0012-01UK	FAN DC 12V RoHs	1
****102	FN1012	FAN GUARD METAL 120MM (FG-12)	1
****201	000-P00312-W	M3X12 MSCR PAN W/FS PAS	4



## 20 COLOUR CODE

20

WIRE COLOUR CODE TABLE

### WARNING

The DC power wire color for this product is different from previous SEGA titles. Working from the previous wire colors will create a high risk of fire.

The color codes for the wires used in the diagrams in the following chapter are as follows.

A	PINK
B	SKY BLUE
C	BROWN
D	PURPLE
E	LIGHT GREEN

Wires other than those of any of the above 5 single colors will be displayed by 2 alphanumeric characters.

1	RED
2	BLUE
3	YELLOW
4	GREEN
5	WHITE
7	ORANGE
8	BLACK
9	GRAY

If the right-hand side numeral of the code is 0, then the wire will be of a single color shown by the left-hand side numeral (see the above).

Note 1: If the right-hand side numeral is not 0, that particular wire has a spiral color code. The left-hand side character shows the base color and the right-hand side one, the spiral color.

<Example> 51.....WHITE/RED

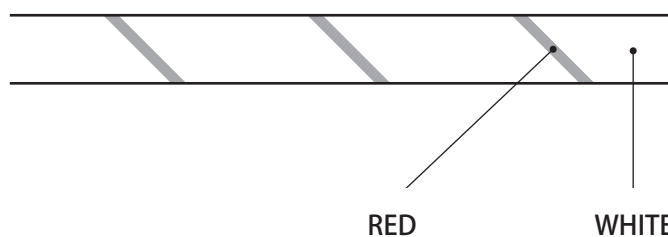

Note 2: The character following the wire color code indicates the size of the wire.

U :	AWG16
K :	AWG18
L :	AWG20
None :	AWG22

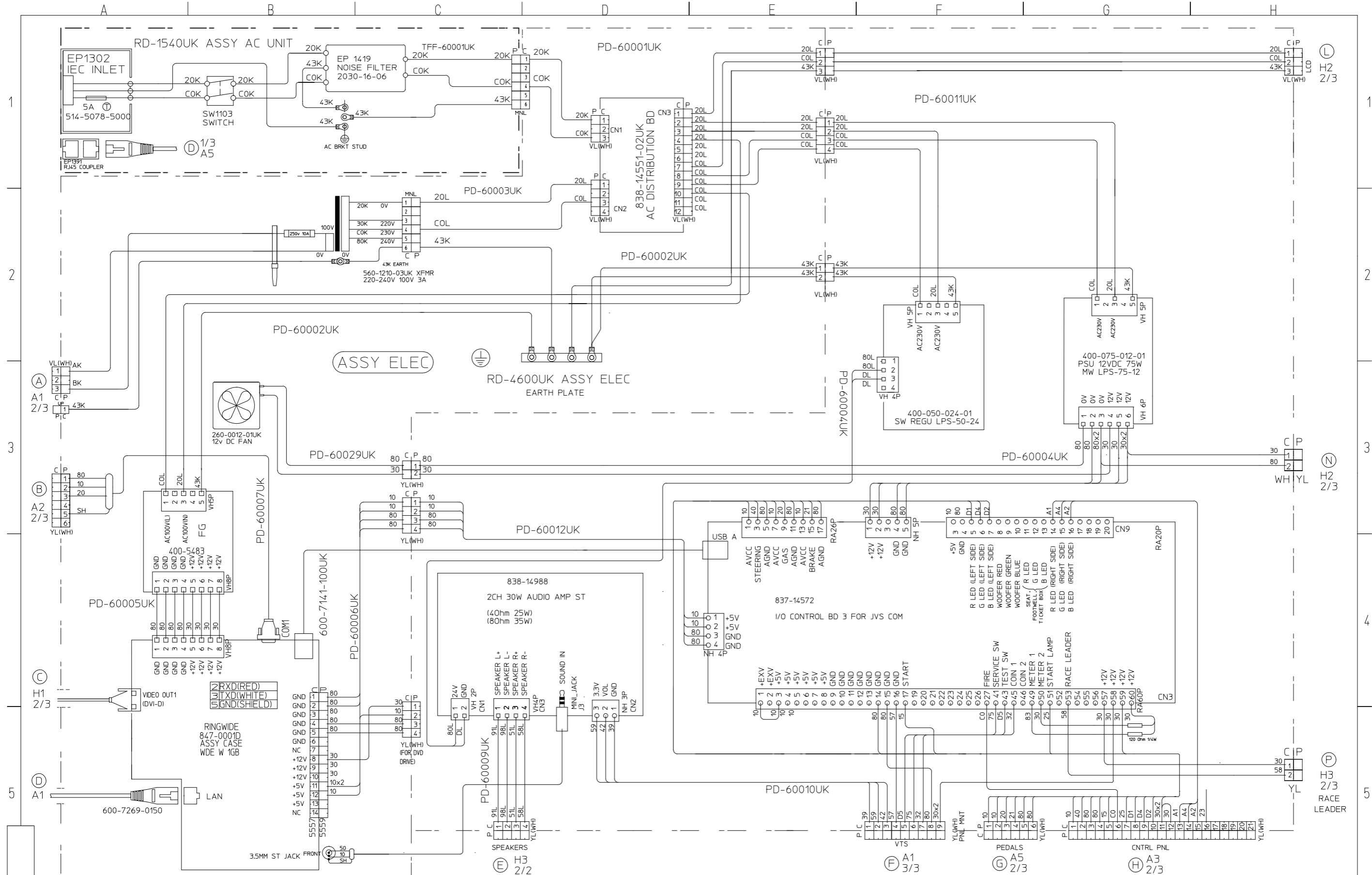

1 RED		8 BLACK		E LIGHT GREEN		DRAWN	CHKD	TOP LEVEL	SEGA AMUSEMENTS EUROPE, LTD.	THIS DRAWING WILL IN NO WAY BE COPIED. TO BE RETURNED ON DEMAND.	ORIGINAL SIZE A3
2 BLUE		9 GREY				RA					
3 YELLOW		A PINK									
4 GREEN		B SKY BLUE									
5 WHITE		C BROWN									
7 ORANGE		D PURPLE									

1	2	3	4	5	6	7	8	9	10	11	12	13	14	15	16	17	18	19	20	21	22	23	24	25	26	27	28	29	30	31	32	33	34	35	36	37	38	39	40	41	42	43	44	45	46	47	48	49	50
1	2	3	4	5	6	7	8	9	10	11	12	13	14	15	16	17	18	19	20	21	22	23	24	25	26	27	28	29	30	31	32	33	34	35	36	37	38	39	40	41	42	43	44	45	46	47	48	49	50

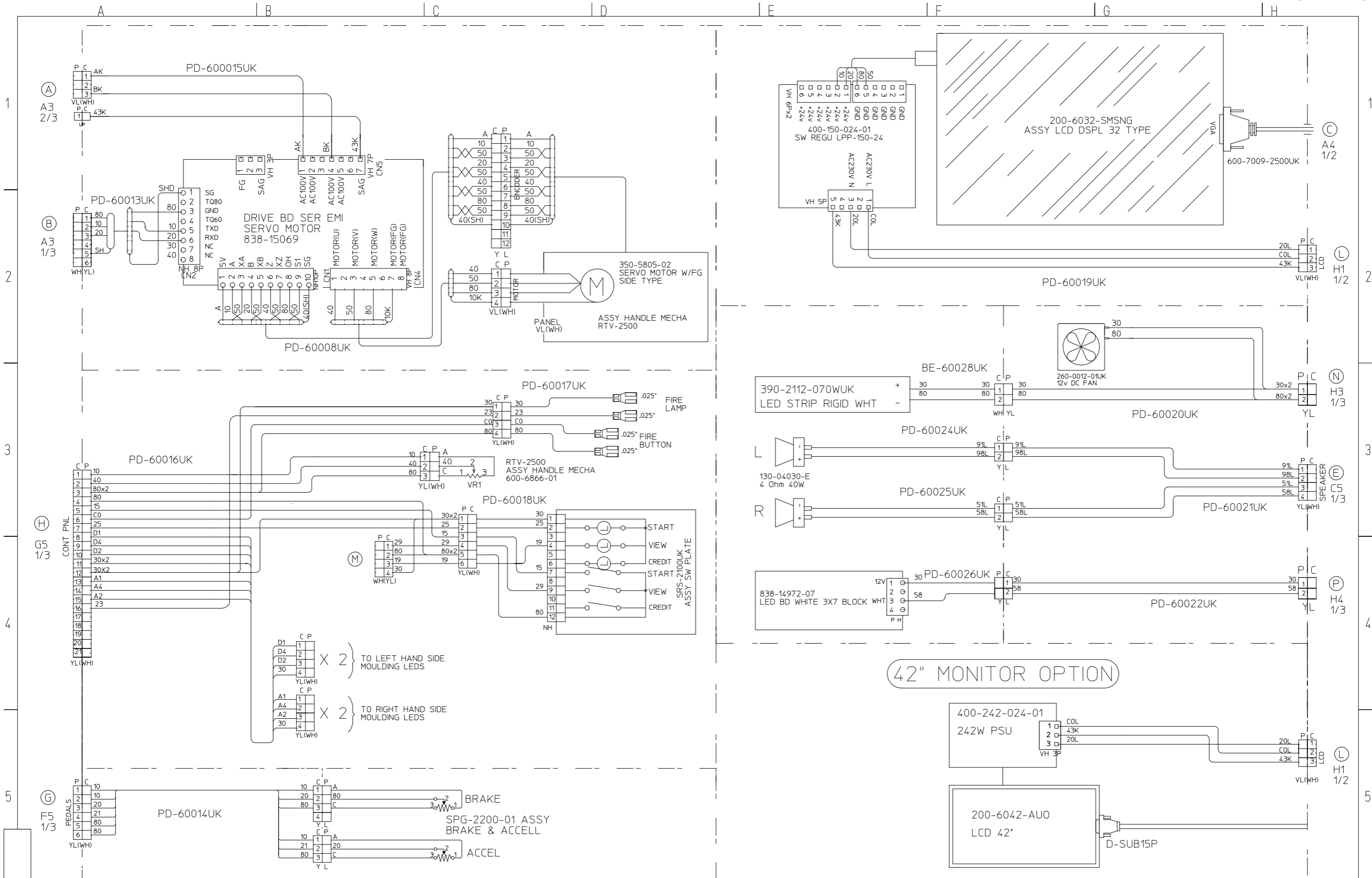

1 RED	8 BLACK	E LIGHT GREEN
2 BLUE	9 GREY	
3 YELLOW	A PINK	U AWG 16 UL1015
4 GREEN	B SKY BLUE	K AWG 18 UL1015
5 WHITE	C BROWN	L AWG 20 UL1007
7 ORANGE	D PURPLE	AWG 22 UL1007

DRAWN	CHKD	TOP LEVEL
RA		

**SEGA** AMUSEMENTS EUROPE, LTD.  
K.O. DRIVE

THIS DRAWING WILL IN NO WAY BE COPIED, TO BE RETURNED ON DEMAND.  
ORIGINAL SIZE A3  
SSR STD 2\_3  
PART NO.

## - SEGA TOTAL SOLUTIONS -

42 Barwell Business Park  
Leatherhead Road,  
Chessington,  
Surrey,  
KT9 2NY  
United Kingdom

Tel: +44 (0) 208 391 8060

Fax: +44 (0) 208 391 8096



# Exclusive Suppliers of SEGA Spares

To Heathrow Airport

