



SILVER

TM

SEGA®

INFOGRAVES

TEEN
TM
T
CONTENT RATED BY
ESRB

T-15108N

WARNINGS Read Before Using Your Sega Dreamcast Video Game System

CAUTION

Anyone who uses the Sega Dreamcast should read the operating manual for the software and console before operating them. A responsible adult should read these manuals together with any minors who will use the Sega Dreamcast before the minor uses it.

HEALTH AND EPILEPSY WARNING

Some small number of people are susceptible to epileptic seizures or loss of consciousness when exposed to certain flashing lights or light patterns that they encounter in everyday life, such as those in certain television images or video games. These seizures or loss of consciousness may occur even if the person has never had an epileptic seizure.

If you or anyone in your family has ever had symptoms related to epilepsy when exposed to flashing lights, consult your doctor prior to using Sega Dreamcast.

In all cases, parents should monitor the use of video games by their children. If any player experiences dizziness, blurred vision, eye or muscle twitches, loss of consciousness, disorientation, any involuntary movement or convulsion, **IMMEDIATELY DISCONTINUE USE AND CONSULT YOUR DOCTOR BEFORE RESUMING PLAY.**

To reduce the possibility of such symptoms, the operator must follow these safety precautions at all times when using Sega Dreamcast:

- Sit a minimum of 6.5 feet away from the television screen. This should be as far as the length of the controller cable.
- Do not play if you are tired or have not had much sleep.
- Make sure that the room in which you are playing has all the lights on and is well lit.
- Stop playing video games for at least ten to twenty minutes per hour. This will rest your eyes, neck, arms and fingers so that you can continue comfortably playing the game in the future.

OPERATING PRECAUTIONS

To prevent personal injury, property damage or malfunction:

- Before removing disc, be sure it has stopped spinning.
- The Sega Dreamcast GD-ROM disc is intended for use exclusively on the Sega Dreamcast video game system. Do not use this disc in anything other than a Sega Dreamcast console, especially not in a CD player.
- Do not allow fingerprints or dirt on either side of the disc.
- Avoid bending the disc. Do not touch, smudge or scratch its surface.
- Do not modify or enlarge the center hole of the disc or use a disc that is cracked, modified or repaired with adhesive tape.
- Do not write on or apply anything to either side of the disc.
- Store the disc in its original case and do not expose it to high temperature and humidity.
- Do not leave the disc in direct sunlight or near a radiator or other source of heat.
- Use lens cleaner and a soft dry cloth to clean disc, wiping gently from the center to the edge. Never use chemicals such as benzene and paint thinner to clean disc.

PROJECTION TELEVISION WARNING

Still pictures or images may cause permanent picture tube damage or mark the phosphor of the CRT. Avoid repeated or extended use of video games on large-screen projection televisions.

SEGA DREAMCAST VIDEO GAME USE

This GD-ROM can only be used with the Sega Dreamcast video game system. Do not attempt to play this GD-ROM on any other CD player; doing so may damage the headphones and/or speakers. This game is licensed for home play on the Sega Dreamcast video game system only. Unauthorized copying, reproduction, rental, public performance of this game is a violation of applicable laws. The characters and events portrayed in this game are purely fictional. Any similarity to other persons, living or dead, is purely coincidental.

TABLE OF CONTENTS

| | |
|--|----|
| Introduction | 4 |
| Getting Started | 5 |
| Jump Pack | 5 |
| Sega Dreamcast Controller | 6 |
| The Main Menu | 7 |
| Saving Your Game | 8 |
| Controlling The Game | 9 |
| Controlling Your Heroes | 10 |
| Combat | 11 |
| Hero Energy Bars | 12 |
| Picking Up Items And Opening Chests | 13 |
| The Pie Menu | 14 |
| The 8 Magic Orbs | 17 |
| How To Use Magic | 18 |
| Organizing Your Party | 19 |
| Speaking With Characters | 19 |
| Rebel Camp | 19 |
| Buying Items | 20 |
| Potions And Vials | 20 |
| Hints And Tips | 20 |
| Credits | 21 |
| Customer Service And Technical Support | 22 |

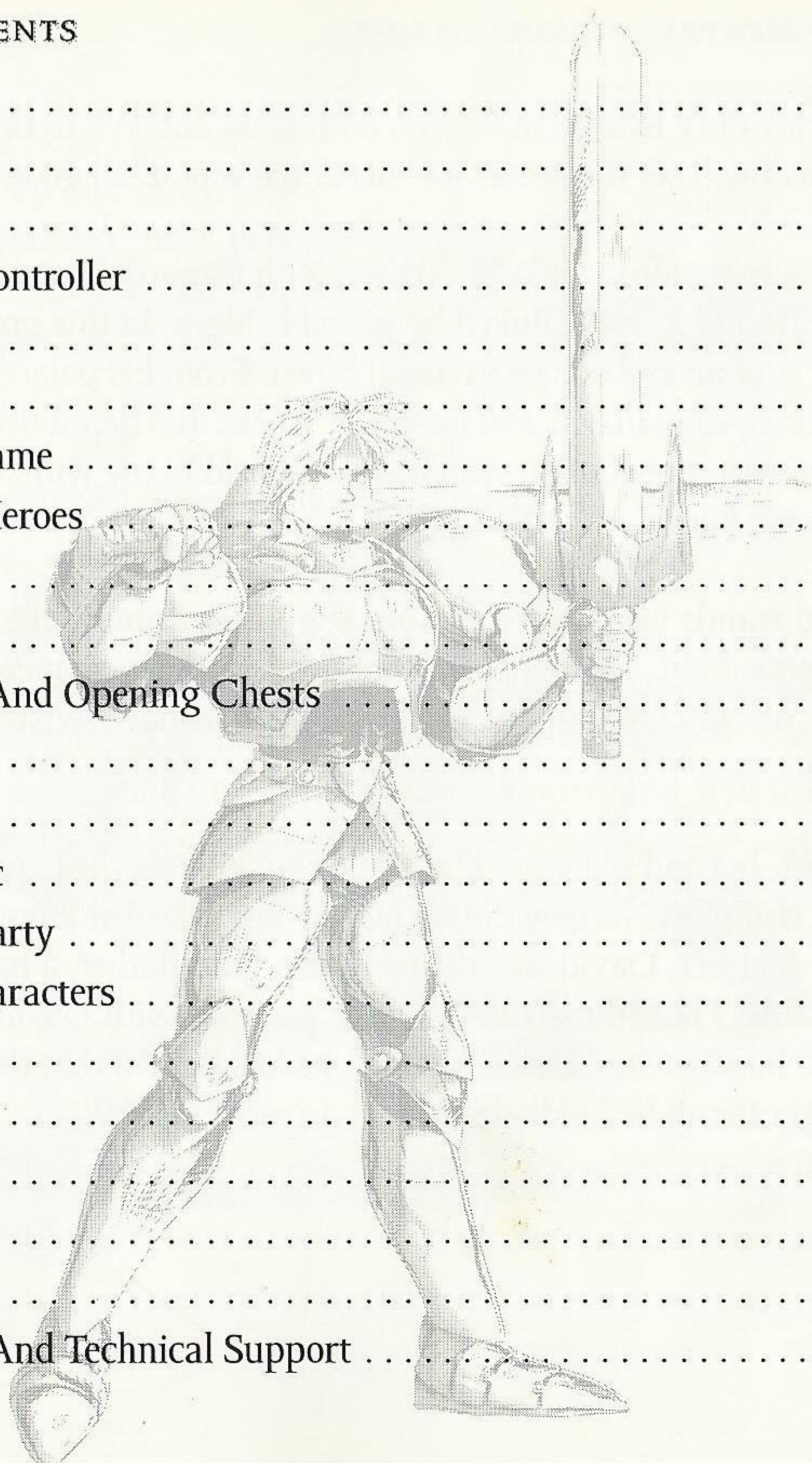

INTRODUCTION

I am the Chronicler, my duty is to record deeds both good and evil in this world and others. Before this tale begins I will set the scene, for this is the way of all good storytellers.

The world of Jarrah is best envisaged as a 'wheel' with tranquil Haven as its hub and the other isles radiating around it, some linked by grand bridges. In this great land, darkness holds sway in the form of an evil sorcerer named Silver. From his palace on the blood-isle of Metalon he rules with an unmatched zeal for ruthlessness and depravity over the Eight Islands. His lust for power, not content with a whole world to toy with, drives him to the most terrible of demonic pacts.

At Silver's right hand stands his murderous son, Fuge. It is through this fearsome warrior that Silver's will is carried out. The people of the isles fear the mere mention of his name. To his left stands Glass, his witch-daughter. Her terrible spells have twisted her realm into the icy domain of Winter.

Far from Silver's court, beyond the great library of Gno, stands the expansive forest of Verdante. It is a peaceful place, largely untouched by its evil ruler. Here lives a young man, David, with his wife Jennifer. David was raised by his grandfather, a battle scarred veteran both wise and honorable. The old man shows great patience with David's youthful attitude, but since the death of his own son, David's father, he has known that the time will come when David must fight for all he holds dear...

GETTING STARTED

SEGA DREAMCAST™ HARDWARE UNIT

- Make sure your Sega Dreamcast™ is properly set-up and ready to go. For more information, refer to the Instruction Manual that came with your Sega Dreamcast.
- Open the Disc Door by pressing the Open Button and insert your Silver Sega Dreamcast Specific Disc. Shut the Disc Door.
- Press the Power Button to start your Sega Dreamcast.
- Follow the on-screen instructions.

Disc Door
Power Button
This turns the unit ON or OFF

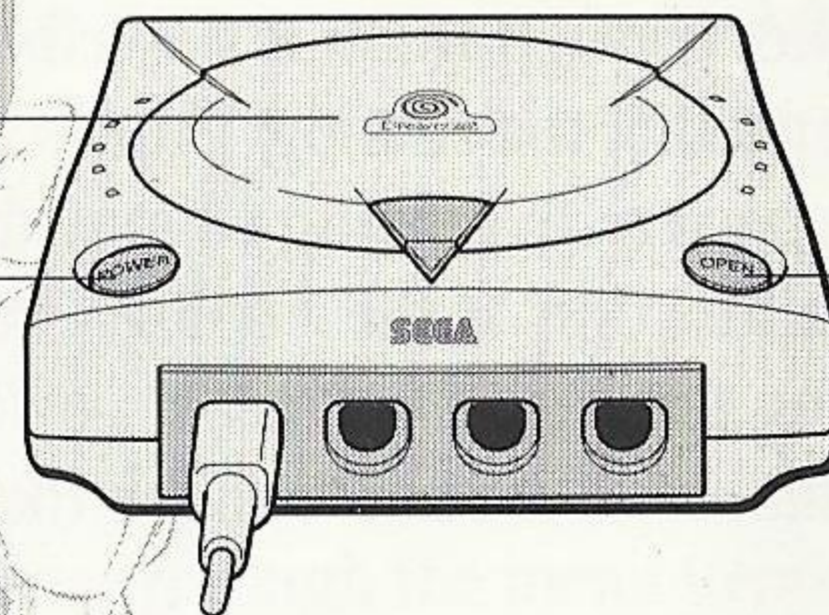

Open Button
Press to open the Disc Door

Silver is a 1-player game. Before turning the Sega Dreamcast power ON, connect the controller(s) or other peripheral equipment into the control ports of the Sega Dreamcast. To return to the title screen at any time, simultaneously press and hold the A, B, X, Y and Start Buttons. This will cause the Sega Dreamcast to soft-reset the software and display the title screen.

JUMP PACK

SEGA DREAMCAST JUMP PACK™

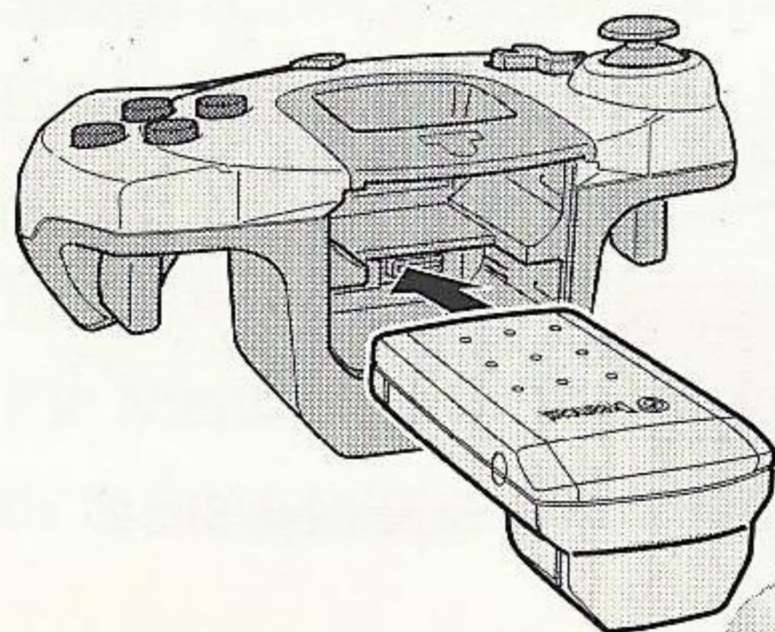

Make sure to insert your Sega Dreamcast Jump Pack into Expansion Socket 2 only. The Jump Pack will not lock into place if inserted into Expansion Socket 1 and may fall out during game play or otherwise inhibit play.

SEGA DREAMCAST CONTROLLER

The controller configuration is described on page 9.

Note: Never touch the Analog Thumb Pad or Triggers L/R while turning the Sega Dreamcast power ON. Doing so may disrupt the controller initialization procedure and result in malfunction. If the Analog Thumb Pad or Triggers L/R are accidentally moved while turning the Sega Dreamcast power ON, immediately turn the power OFF and then ON again making sure not to touch the controller.

Overhead View

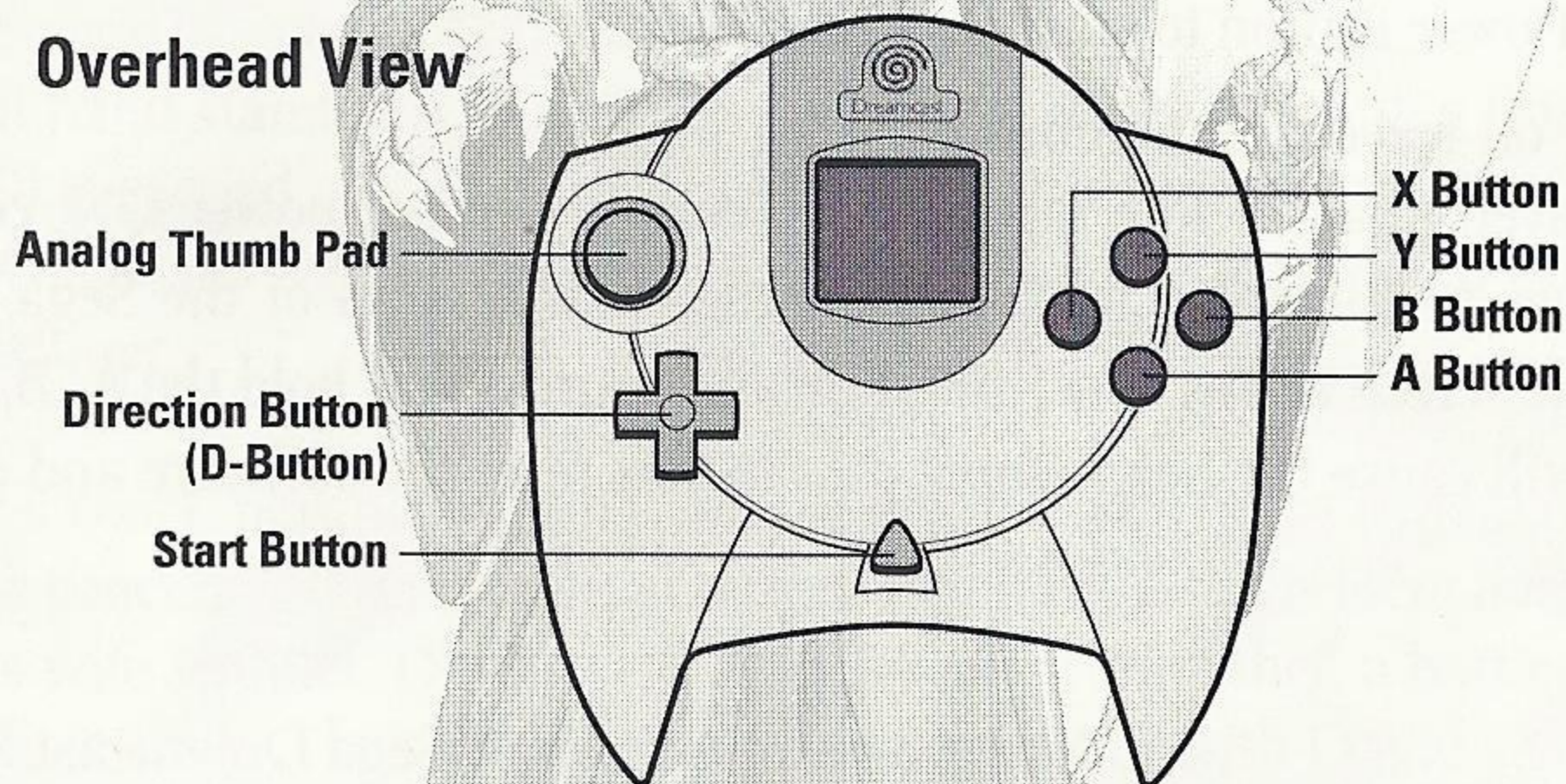

Forward View

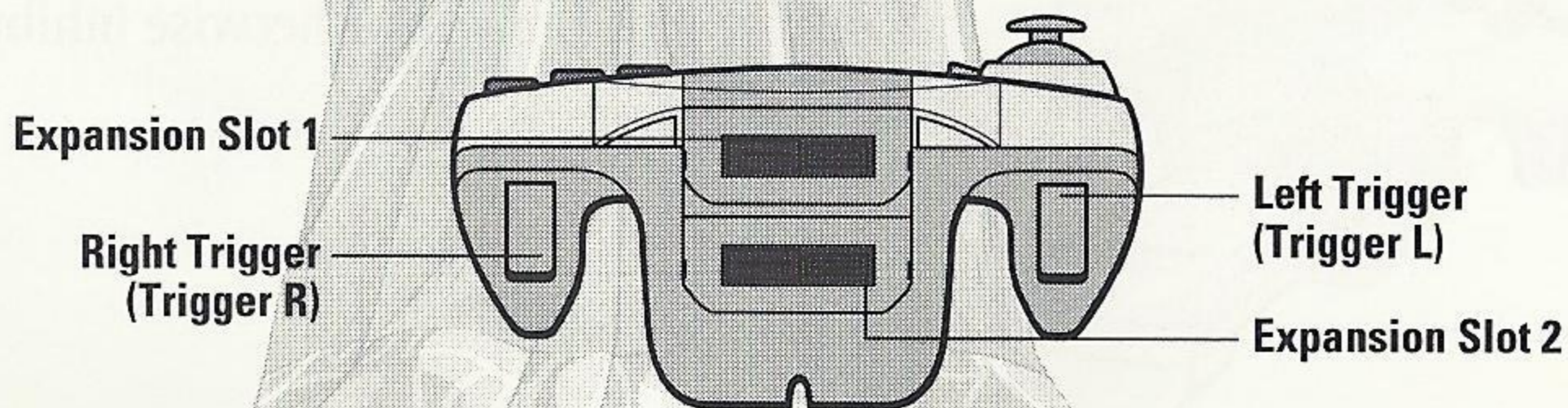

THE MAIN MENU

Once the introductory movie has played, press the Start Button to move to the Main Menu. (You can also press the Start Button to bypass the movie.) The Main Menu offers you the following choices:

- Start
- Load Game
- Options

On all menus, use Directional Button ▲ and ▼ to move through the menu items and press the A Button to make your choice. Press the B Button to back up a screen.

START:

This choice will start a brand new game.

LOAD GAME:

Select this menu item to load a game you have previously saved on your Visual Memory Unit (VMU). Use D-Button ▲ and ▼ to highlight the up or down arrow, and press the A Button to scroll through your games. When you have selected the game you want to load, highlight "Load" and press the A Button. Select "Back" to return to the Main Menu without loading a game. (See page 8 for information on how to save a game.)

OPTIONS:

This menu item will bring up the following sub-menu:

Preferences: Set your game preferences here.

Sound: Change your sound options from this menu.

Back: Returns you to the Main Menu.

Preferences:

- Item Descriptions: Turn the brief item descriptions of the Pie Menu items on or off.
- Pie Menu Pause: You can set the game to Pause when you open the Pie Menu (Yes) or to keep going while you access the Pie Menu (No).

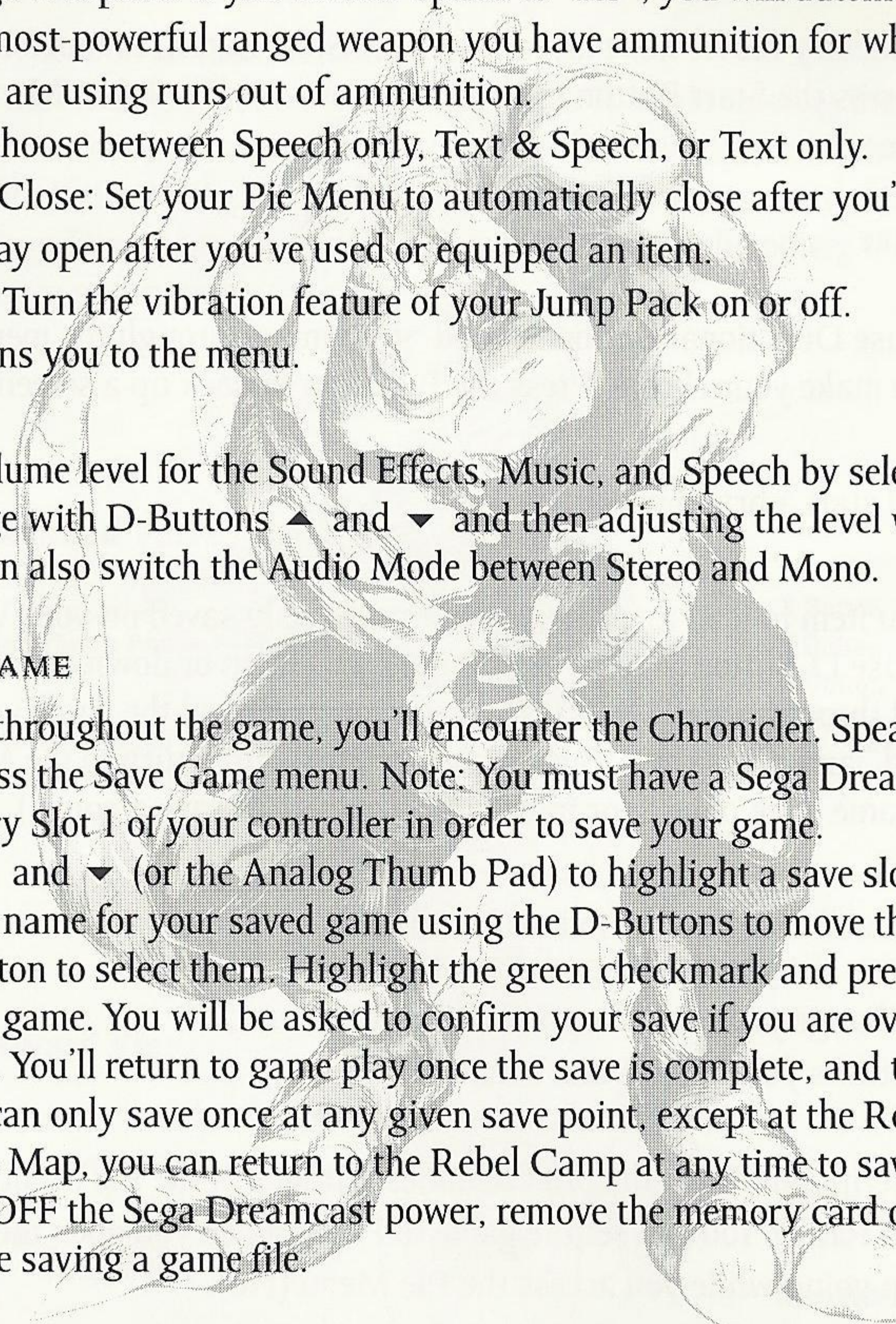
- 
- Auto Change Weapons: If you set this option to 'Yes', you will automatically change to the next most-powerful ranged weapon you have ammunition for when the ranged weapon you are using runs out of ammunition.
 - Dialogue: Choose between Speech only, Text & Speech, or Text only.
 - Menu Auto Close: Set your Pie Menu to automatically close after you've made a choice, or stay open after you've used or equipped an item.
 - Jump Pack: Turn the vibration feature of your Jump Pack on or off.
 - Back: Returns you to the menu.

Sound:

You can set the volume level for the Sound Effects, Music, and Speech by selecting the item you want to change with D-Buttons ▲ and ▼ and then adjusting the level with D-Buttons ◀ and ▶. You can also switch the Audio Mode between Stereo and Mono.

SAVING YOUR GAME

At various points throughout the game, you'll encounter the Chronicer. Speak to the Chronicer to access the Save Game menu. Note: You must have a Sega Dreamcast VMU inserted in Memory Slot 1 of your controller in order to save your game.

Use D-Buttons ▲ and ▼ (or the Analog Thumb Pad) to highlight a save slot and press the A Button. Enter a name for your saved game using the D-Buttons to move through the letters and the A Button to select them. Highlight the green checkmark and press the A Button to save the game. You will be asked to confirm your save if you are overwriting a pre-existing game. You'll return to game play once the save is complete, and the Chronicer will be gone; you can only save once at any given save point, except at the Rebel Camp. Once you have the Map, you can return to the Rebel Camp at any time to save your game. Note: Never turn OFF the Sega Dreamcast power, remove the memory card or disconnect the controller while saving a game file.

CONTROLLING THE GAME

Silver has two basic modes: movement and combat. Below are diagrams with the controls for each mode:

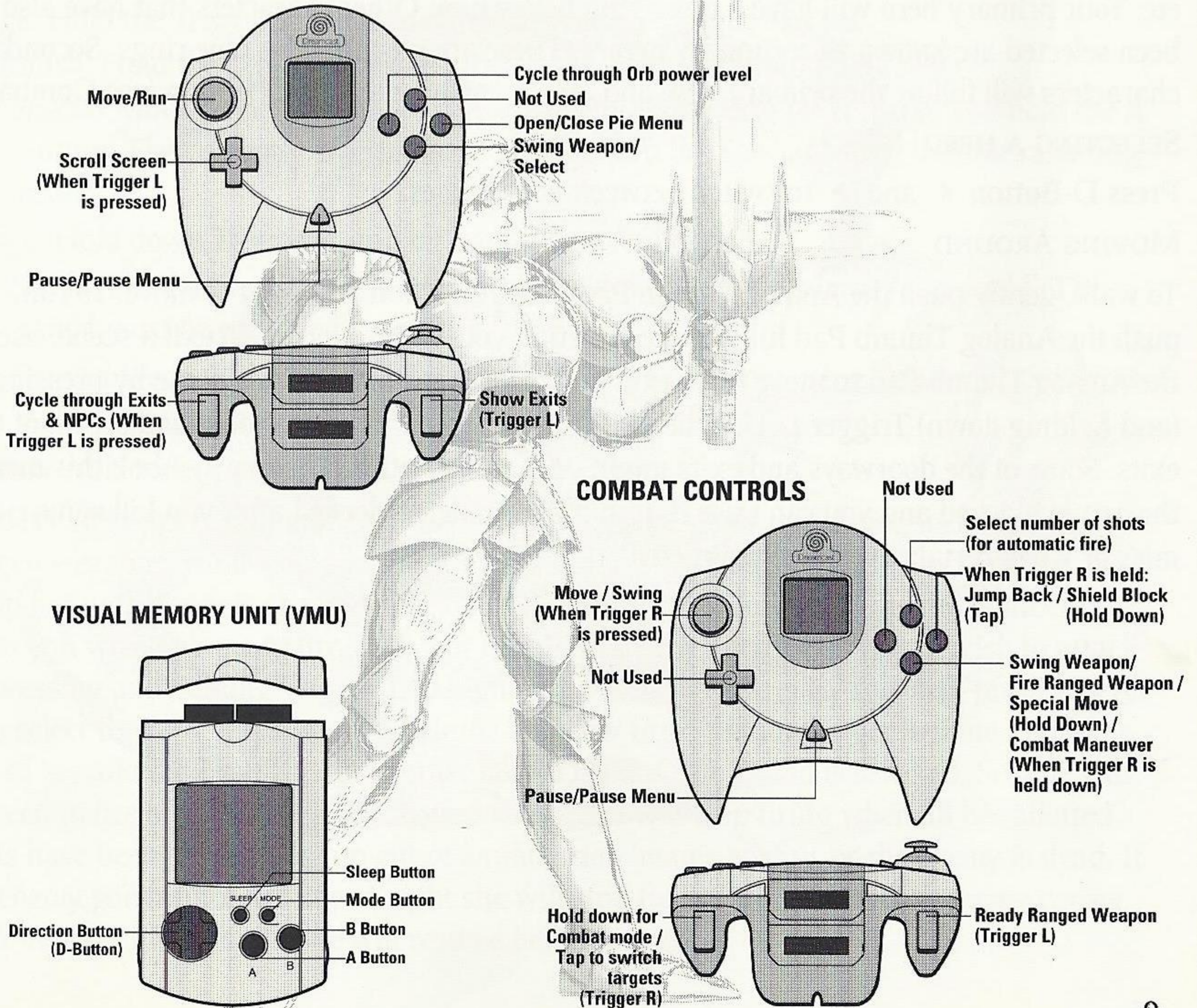

CONTROLLING YOUR HEROES

Throughout the game, one of the heroes will be under your direct control (known as the primary hero). Being under direct control means that you, as the player, are responsible for controlling that hero's actions during combat, talking to other characters, opening chests, etc. Your primary hero will have a green ring below him. Other characters that have also been selected are known as secondary heroes. These are identified by blue rings. Secondary characters will follow the primary hero and attack enemies that you click on (see Combat).

SELECTING A HERO

Press D-Button ◀ and ▶ to switch between your heroes.

MOVING AROUND

To walk, gently push the Analog Thumb Pad in the direction you want to move. To run, push the Analog Thumb Pad fully in the direction you want to move. To exit a scene, use the Analog Thumb Pad to move to an exit. You can see the exits from a scene by pressing (and holding down) Trigger L. Use the D-Button to scan around the room and see all of the exits. Some of the doorways and exits might be marked with a no-entry symbol; this means the exit is blocked and you can't use it. It might become unblocked after you kill some enemies or when certain events are triggered.

COMBAT

Quick slash/jab: Hold Trigger R and press the A button.

Left slash: Hold Trigger R while moving the Analog Thumb Pad to the left.

Right slash: Hold the Trigger R while moving the Analog Thumb Pad to the right.

Lunge: Hold the Trigger R while moving the Analog Thumb Pad up.

Backslash: Hold the Trigger R while moving the Analog Thumb Pad down.

Use Special Move: When in weapon range while pressing Trigger R, press and hold the A Button. The currently selected hero will perform the Special Move, with devastating results.

Dodge: Hold down Trigger R and tap the B Button to dodge.

Use Shield: Hold down Trigger R, press and hold the B Button to use your shield (The shield must be equipped).

Fire Ranged Weapon: Hold down Trigger L, select your enemy using Trigger R and press the A Button to fire.

AUTOMATED FIRING OF MAGIC AND RANGED WEAPONS

Heroes can be set to automatically fire a set number of shots at a target, using magic or ranged weapons, while you take control of another hero. For example: Select Sekune and equip her with a magic or ranged weapon. Pressing the Y Button selects the number of shots you wish Sekune to fire, 1, 3, 5 or infinite shots. Select an enemy you wish to attack by pressing and holding Trigger L to highlight the enemy currently selected, press Trigger R to select the next enemy target. Sekune will now fire one shot. To get Sekune to fire the rest of her allotted shots, select another hero, David. Once David is selected, Sekune will proceed to fire off the rest of her allotted shots. She will stop firing when all her allotted shots have been fired, she's run out of ammunition/magic energy, or the enemy is dead. If the enemy goes out of her line of sight she will stop firing. If and when the enemy comes back into her line of sight she will resume her attack.

SPECIAL MOVES

Specials are powerful attacks used in conjunction with hand weapons. These can be collected, or taught by another character. Special moves charge up with power, like magic items. When they are recharged, the Special icon will appear in the top right hand corner of the screen. To use a Special, equip it and attack an enemy. When in weapon range, press the R Trigger, press and hold the A button. The currently selected hero will perform the Special Move, with devastating results.

HERO ENERGY BARS

Each hero's portrait is displayed in the top left-hand corner of the screen. The primary hero's portrait has a green box around it. Below these are three energy bars. The first shows the hero's health points. This bar will change color as the hero is injured, from green (indicating full health), to red (badly injured). The second energy bar shows the hero's magic points; white (indicating maximum magic points), diminishing to a dark blue as more points are used. The final purple bar indicates the strength of the hero's currently selected shield (if any).

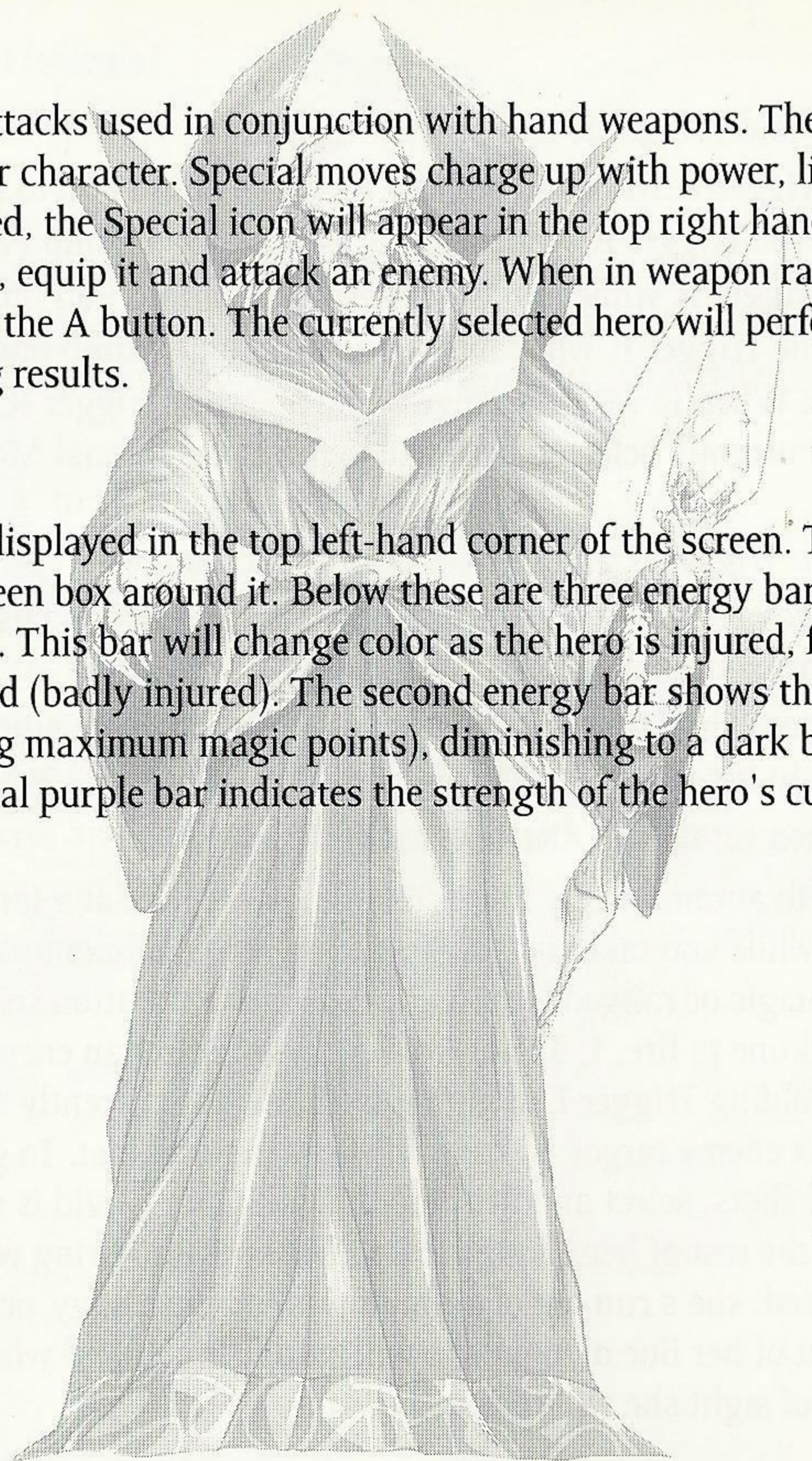

PICKING UP ITEMS AND OPENING CHESTS

PICKING UP ITEMS

Walk or run over the object to pick it up. The item collected will be displayed in the top right hand corner of the screen. You can also move over and pick the item up by holding down Trigger L, pressing Trigger R to highlight the item, and then pressing the A Button (double tap the A Button to run to the item.) This technique also works for opening chests, activating switches, unlocking doors, and talking with NPCs.

OPENING CHESTS

Walk up to the chest until a hand icon appears above it. Press the A Button to open it. Some chests are locked and need to be unlocked before you can open them. See the section on Unlocking Doors (below) for information on how to open locked chests.

ACTIVATING SWITCHES

Pressing Trigger L while in Move mode will reveal switches as well as doors. Trigger R will select a switch (if there is more than one switch or door present), and pressing the A Button will activate it.

UNLOCKING DOORS

Pressing Trigger L will reveal locked doors. The required key will be displayed over the door icon. Press Trigger R to select the door (if there is more than one door present in the scene) and then press the A Button to unlock it.

STORY OBJECTS

These object will automatically be used when you speak with certain characters or when you select certain background objects. There may be some places where you will need to acquire certain story objects before you can progress beyond them

THE PIE MENU

The pie menu is used to equip heroes with weapons, shields and magic. It also gives access to a character's statistics.



To bring up the pie menu press the B Button. Use the Analog Thumb Pad to highlight the desired sub-menu and press the A Button to select it. Again, use the Analog Thumb Pad to select the item or weapon you'd like to equip or use and press the A Button. When an item is equipped, a green gem is displayed next to it in the Pie menu. Press the B Button to exit a sub-menu or exit the Pie Menu.

Note: You have the option of having game play continue while activating the Pie Menu, or having game play pause. The default is for game play to continue. You may change this setting in the Options Menu.

For example, to equip the short sword and wooden shield:

1. Press the B Button to bring up the Pie Menu.
2. Move the highlight around with the Analog Thumb Pad until the Hand Weapon sub-menu is highlighted and press the A Button.
3. Use the Analog Thumb Pad to highlight the short sword and press the A Button.
4. Press the B Button to bring up the Pie Menu again.
5. Use the Analog Thumb Pad until the Shield sub-menu is highlighted. Press the A Button to enter this sub-menu.
6. Use the Analog Thumb Pad to highlight the wooden shield and press the A Button to equip it.
7. Press the B Button to exit the sub-menu, then press the B Button again to exit the Pie Menu. David will now be equipped with the short sword and shield.

The Pie Menu also displays:

- The heroes in the group (Press the A Button without moving the Analog Thumb pad to cycle through the heroes.).
- The health of the currently selected hero (shown in white numbers).
- The magic energy of the currently selected hero (shown in blue numbers).

SUB-MENUS



Food:

 Each food type collected is shown here. The number at the bottom right of each icon shows the amount you are carrying. After selecting the type of food you'd like the selected hero to eat, press the A Button. The current hero will eat the food. (Each type of food replenishes a varying amount of health, so healthy eating is the key to survival!)



Magic Orbs:

 In order to defeat Silver, you must collect all eight of the magical orbs. Each of the orb has some useful abilities, and to use those abilities, you need to have a hero equip it. However, only one hero can use a given orb at any given time, as there is only one of each of the orbs

Ranged weapons

  This sub-menu shows all of your ranged weapons, from catapult to longbow. The number at the bottom right indicates the amount of that type of weapon you have collected. The gold/silver ring shows how much ammunition you have for that type of weapon. The number top left indicates how many shots a secondary hero will use up during automated firing (see page 11).

Magic Items:

  Equip these items to cast some powerful magic spells. Each magic item has its own energy supply, which slowly recharges after use. This energy is displayed as a gold/silver ring around the icon. While some of the magic items are weapons, other are of a more defensive nature.



Shields:

 These can be used to block physical and magical attacks. A shield can only take so much before it is destroyed, however different shields can absorb different amounts of damage before shattering. Every time a shield blocks an attack, it loses strength points. Your shield's strength is displayed as a purple energy bar under the portrait of the hero who has it equipped. In the Pie Menu, shield strength is shown as the familiar gold/silver ring around the shield icon. A hero can't use a shield while he is using a ranged weapon or a magical orb, as those items require two hands to operate.

Melee Weapons:

 You'll find everything from short swords to war hammers. Try to equip a hero with a weapon that best suits his or her personality.

Specials:

  You need to equip special moves in order to use them. Since a special move is knowledge, and not an actual item, you can equip more than one character with the same special at the same time. The gold/silver ring around the icon shows if the move is ready to be used, or if it is still recharging.

Backpack:

 This is used for carrying several different types of items. These are:

 *Inventory:* This displays all the items that the party is carrying. It also shows the currently selected hero's statistics, total gold collected and arrows found. Once you have found the map of Jarrah, you can access it from the inventory screen, and use it to travel between locations you have already visited. To use it, select the map icon and press the A Button. Use the Analog Thumb Pad to select your destination and press the A Button to go there.

 *Potions:* Displays the different types of potions and vials carried. See page 20 for information on how to use potions and vials.

 *Keys:* This will show you all the keys the party is carrying.

The Backpack also has five empty slots, which are used for holding miscellaneous story items.

THE 8 MAGIC ORBS

David and his friends must collect 8 magic orbs in order to defeat the evil Silver. Each orb is based around one type of magic, such as fire or ice. They can be used as great weapons or as powerful defenses, depending on the individual orb. The number, bottom right, indicates the current level of the magic orb.

Each orb has three levels of strength. When you first find an orb, it is at the first level of strength. The more it is used, the quicker it will become more powerful. Once the orb has been upgraded to a higher level, you can set it back to a lower level of power to conserve your mana, if you wish. Press the X Button to cycle through the orb's power levels.

HOW TO USE MAGIC

Magic can be used in two ways. You can cast a spell at range, from your hero's hand towards a target, or you can cast a spell as an area effect, in the immediate vicinity of your hero. Every time you cast a magic spell, you'll use some of your character's magical energy; make sure you have enough energy before you try to cast a spell!

RANGED MAGIC

First, select the enemy you wish to attack by pressing and holding Trigger L to highlight a foe. Pressing Trigger R will select the next enemy target. Once you have the proper target in your sights, press the A Button to cast your spell.

AREA MAGIC

To cast a spell on an area, hold down Trigger R and then press and hold the A Button.

Your magical energy will slowly regenerate once you've cast a spell. You can speed up this process by collecting the blue orbs that are dropped by certain enemies.

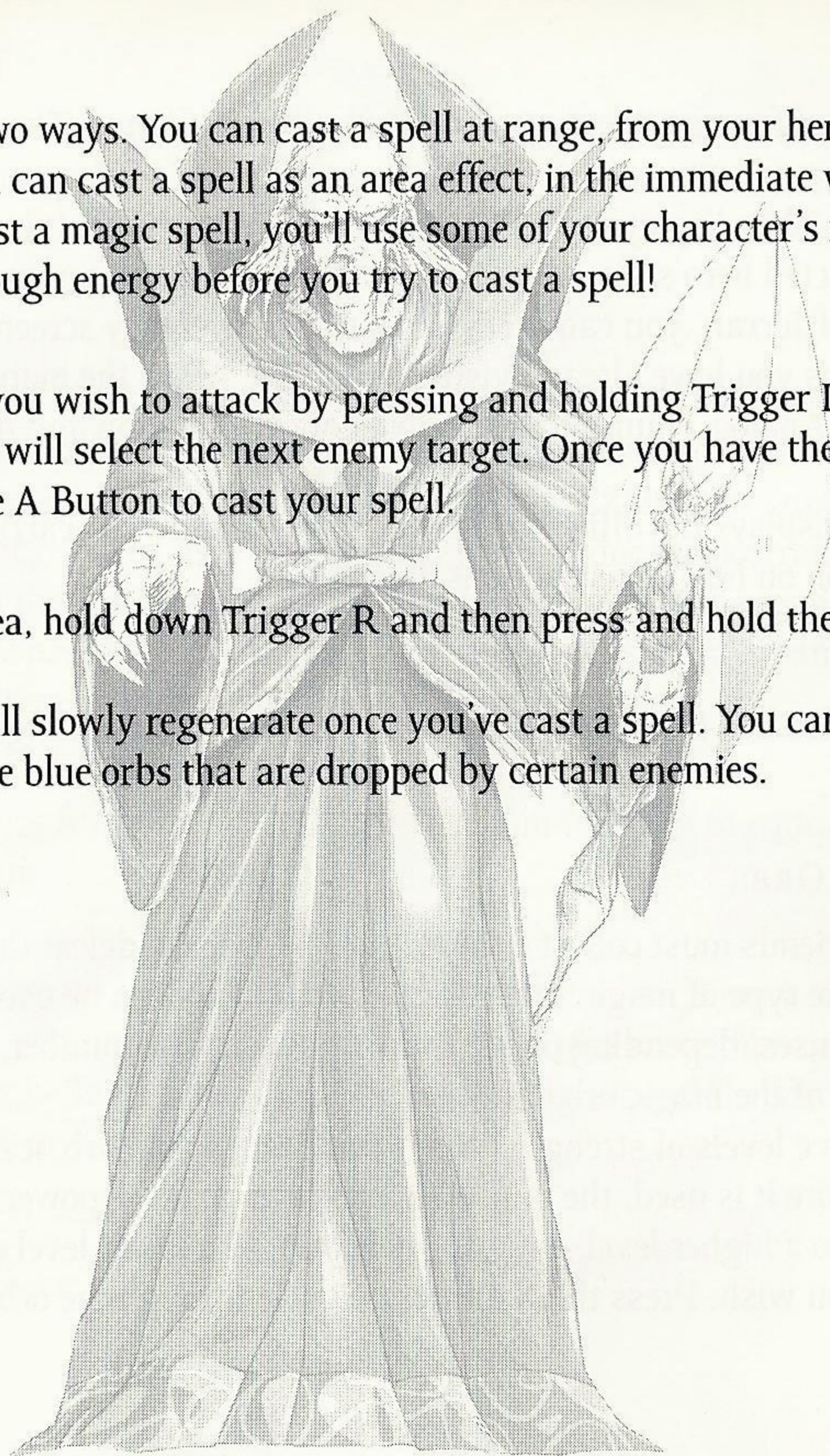

ORGANIZING YOUR PARTY

During the course of your adventures, David will be joined by other heroes. You may have two other heroes (in addition to David) in your party at any one time. When you meet a hero for the first time, they may elect to join your party. If they do, a hero selection box will appear, displaying the portraits of those heroes. Highlight the portrait you wish to select/de-select with the Analog Thumb Pad. Press the A Button to select a hero and the B Button to de-select a hero. To confirm your selections, highlight the checkmark and press the A Button. Once a hero is deselected he will usually return to the Rebel camp.

SPEAKING WITH CHARACTERS

To communicate with characters, walk up to them and face them. Once the mouth icon appears, press the A Button. To have your hero walk over and speak with an a character, hold down Trigger L, press Trigger R to select the appropriate character, and then press the A Button.

By talking to characters, different heroes may join your quest. To pass through each section of speech/text, simply press the A Button.

REBEL CAMP

Whenever you reach an impasse in the game or need information, return to the camp. Talking to the rebels can sometimes reward you with information and a special move or two.

It also gives you a chance to swap heroes: Use David to talk to any of the heroes waiting in the camp. Once you have spoken to them, select the hero or heroes you wish to take with you. When you leave the scene they will follow. If you are unhappy with your selection, speak to one of the waiting heroes again.

BUYING ITEMS

You will find gold coins as some of the treasure during your adventures. You can use these coins to buy food, information, or helpful items. To buy items, talk to the trader. You will be shown the items the trader wishes to sell. The number above the item is the price. The number at the bottom right of the item displays how many of that item you already have.

To buy, highlight the desired item with the Analog Thumb Pad and press the A Button. The money will be automatically deducted from your gold reserve. To cancel the sale, press the B Button (sell back). Highlight the checkmark when you are happy with your purchases and press the A Button. Highlight the "x" and press the A Button to leave the trader without buying anything.

POTIONS AND VIALS

Potions convey healing or protective magic to the drinker. To use them, simply select the potion in the Pie Menu and press the A Button. Vials are offensive weapons which you can throw at enemies. To use vials, select them with the Analog Thumb Pad and press the A Button to equip it. When you are moving or in combat, hold down Trigger L, select your enemy with Trigger R and then press the A Button to use the vial.

HINTS AND TIPS

- Deep within the forests of Jarrah lies a fairy ring fabled for its healing properties.
- Traders often bring new goods to sell — it is worth checking them frequently.
- All the heroes have different abilities; some excel at magic while others favor particular weapons. Experimentation is the key.
- Not all orbs are offensive. Try using some of them on your other heroes.
- Granddad is very protective of David. Should you be at death's door, Granddad will intervene and do anything in his power to save you.
- Keep an eye out for little green imps. They're very fond of certain areas!

CREDITS

PRODUCTION

EXECUTIVES:

VP Label

Olivier Goulay

Production Director

Morgan O'Rahilly

Operation Manager

Eric Labelle

Label Marketing Director

Larry Sparks

Label Marketing Manager

Monique Crusot

DREAMCAST

CONVERSION —

SPIRAL HOUSE LTD

Senior Programmer

Robbie Tinman

Music Conversion

Ray Shulman

Artists

Ray Coffey

Adrian Page

Colin Rushby

Jack Wikeley

Chris Johnson

Dylan Bourne

Programmers

Mike Ferenduros

Marc Littlemore

Matthew Brookes

Technical Coordinator:

Bobby Earl

Coordinator:

Kevin Oxland

INFOGRAMES

Producer

Judi Spiers

Product Manager

Cyril Voiron

Public Relations

Paul Fox

Label Artist

Patrick Chouzenoux

Technical Department

Jean-Marcel Nicolai

Rebecka Pernered

Céline Laurensen

QA Manager

Olivier Robin

Localization

Chrystelle Dozoul

Qualitative Section

Supervisor:

Dominique Morel

Coordinator:

Emmanuel Cholley

Team Leader:

Jocelyn Cioffi

Debugging Section

Supervisor:

Stéphane Pradier

Coordinator:

Vincent Hattenberger

Lead Tester:

Agnès Burdin

Testers:

(DEBUGGING SECTION)

Elvis Alvarez

Yann-Gaël Fourquier

Fabrice St Michel

Jean-Christophe Imbert

(QUALITATIVE SECTION)

Tatiana Junqueira

Stéphane Rizzo

Leila Soui

Localization Testing:

Merche Sanchez Garcia

INA Executive Producer:

Kurt Busch

INA Senior Producer:

Francois Lourdin

INA Lead Tester:

Chris Sur

INA Testers:

Bill Fitts

Rick Brock

Jason Cote

David L. Strang

INA Marketing:

David Riley

Heather Hall

Manual (U.S.):

Bruce Harlick

W.D. Robinson

Creative Services (U.S.):

Sheryl Knowles

Eric Larson

Special Thanks to

Pierre Vu

Patrick Gras

Cindy Church

Emmanuelle Tahmazian

Sophie Wibaux

Sugar to Kirby Fong

Joy Schneer

Michael Gilmartin

Music vocal samples were

courtesy of Spectrasonics'

"Symphony of Voices"

Voice Production: Philip

Morris Music and Voice

Production (AllintheGame

Ltd)

CUSTOMER SERVICE AND TECHNICAL SUPPORT

Infogrames Entertainment, S.A. provides customer service, news, demos and technical support on these on-line services:

Phone: Infogrames Entertainment, S.A. has some of the friendliest and knowledgeable Technical Support Representatives in the industry. We can help you by phone between the following hours: Monday - Thursday 8:00 am - 1:00 pm, 2:00 pm - 5:00 pm Pacific time and Friday 9:00 am - 1:00 pm, 2:00 pm - 5:00 pm Pacific time at (408) 296-8400.

FAX: Faxes may be sent anytime to: (408) 246-0231. Please include your phone number on all fax transmissions.

Online: <http://www.ina-support.com>
<http://www.silvergame.com>

Postal Contact: Infogrames Tech Support
5300 Stevens Creek Blvd., Ste. 500
San Jose, CA 95129

INFOGRAMES HINT LINE

1-900-454-HINT: \$.99/minute. If you're under 18, please get a parent's permission before calling.

OTHER INFOGRAMES PRODUCTS

To order other fine products from Infogrames, call 1-800-245-7744 or visit our web site, <http://www.us.infogrames.com>.

90-Day Warranty

Infogrames Entertainment, S.A. warrants for a period of 90 days from the date of purchase by the original purchaser of this software that the medium on which it is recorded will be free from defects in materials and workmanship. Defective media which has not been subjected to misuse, excessive wear or damage due to carelessness may be returned during the 90-day period without charge. To receive warranty service:

1. DO NOT return your defective disk to the retailer.
2. Notify Infogrames Entertainment, S.A. Customer Service of the problem by calling (408) 296-8400 between the hours of Monday - Thursday 8:00 am - 1:00 pm, 2:00 pm - 5:00 pm and Friday 9:00 am - 1:00 pm, 2:00 pm - 5:00 pm (Pacific Time). Please do not send your disc to Infogrames Entertainment S.A. before calling. Infogrames Entertainment S.A. can also be reached 24 hours a day by FAX at (408) 246-0231 or on the World Wide Web at <http://www.ina-support.com>.
3. If a Customer Service Technician is unable to solve this problem by phone, you will be given a Return Authorization number. Record this number on the outside packaging of your disc (be sure your packaging is at least 4" x 6", as many shipping companies will not ship anything smaller.) Send the disc and your sales slip or similar proof-of-purchase within the 90-day warranty period to: Customer Service, Infogrames Entertainment S.A., 5300 Stevens Creek Blvd., Suite 500, San Jose, CA 95129.

After the 90-day period, defective media may be replaced in the United States for \$10 (U.S. dollars; plus 8.25% sales tax if the purchaser resides in California). Make checks payable to Infogrames Entertainment, S.A. and return to the address listed above. (To speed processing, please do not return manuals or game boxes.)

IN NO EVENT SHALL INFOGRAMES ENTERTAINMENT, S.A. BE LIABLE FOR ANY DIRECT, SPECIAL, INCIDENTAL OR CONSEQUENTIAL DAMAGE WITH RESPECT TO THE SOFTWARE OR USER MANUAL EXCEPT AS PROVIDED ABOVE. INFOGRAMES ENTERTAINMENT, S.A. MAKES NO WARRANTIES, EITHER EXPRESS OR IMPLIED, WITH RESPECT TO THE SOFTWARE OR USER MANUAL, AND EXPRESSLY DISCLAIMS ALL IMPLIED WARRANTIES, INCLUDING WITHOUT LIMITATION, THE WARRANTY OF MERCHANTABILITY AND OF FITNESS FOR A PARTICULAR PURPOSE.

LEGAL NOTICE

© Infogrames Entertainment, S.A. 2000. All rights reserved. Developed by Spiral House Ltd. Silver and Infogrames are trademarks of Infogrames Entertainment, S.A.

ESRB RATING

This product has been rated by the Entertainment Software Rating Board. For information about the ESRB rating, or to comment about the appropriateness of the rating, please contact the ESRB at 1-800-771-3772.

Sega is registered in the U.S. Patent and Trademark Office. Sega, Dreamcast, and the Dreamcast logo are either registered trademarks or trademarks of SEGA Enterprises, Ltd. All Rights Reserved. This game is licensed for use with the Sega Dreamcast system only. Copying and/or transmission of this game is strictly prohibited. Unauthorized rental or public performance of this game is a violation of applicable laws. © SEGA ENTERPRISES, LTD., 2000. Sega of America, P.O. Box 7639, San Francisco, CA 94120. All rights reserved. Made and printed in the USA.

Product covered under one or more of the following: U.S. Patents No's: 5,460,374; 5,627,895; 5,688,173; 4,442,486; 4,454,594; 4,462,076; Re. 35,839; Japanese Patent No. 2870538 (Patents pending in U.S. and other countries); Canadian Patent No. 1,183,276.

This game is not suitable for the hearing impaired.

SEGA[®]

AVAILABLE NOW!



www.slavezero.com

Infogrames Entertainment S.A. 5300 Stevens Creek Blvd. Suite 500 San Jose, CA 95129 1-800-245-7744 www.us.infogrames.com
Silver © 2000 Infogrames Entertainment S.A. All Rights Reserved. Silver developed by Spiral House.
Silver and Infogrames are trademarks of Infogrames Entertainment S.A.

Sega is registered in the US Patent and Trademark Office. Sega Dreamcast, the Dreamcast Swirl, are trademarks of SEGA, Sega of America, P.O. Box 7639, San Francisco, CA 94120. All Rights Reserved. Programmed in Japan. Made and printed in the USA. WARNING: Operates only with NTSC televisions and Sega Dreamcast systems purchased in North and South America (except Argentina, Paraguay and Uruguay). Will not operate with any other televisions or Sega Dreamcast systems. Product covered under one or more of the following U.S. Patents: 5,460,374; 5,525,770; 5,627,895; 5,688,173; 4,442,486; 4,454,594; 4,462,076; Re. 35,839; Japanese Patent No.2870538, (Patents pending in U.S. and other countries), Canada Patent No. 1,183,276. The ratings icon is a trademark of the Interactive Digital Software Association.

